



DELTA HAND WINCHES

500kg - 1200kg

FEATURES INCLUDE

- **Rated for lifting applications**
From 440kg to 1200kg on first layer
- **Compact design**
- **Available in galvanized (G) or stainless steel (S) finish**
- **Ratchet Brake**
- **Light weight, simple to use**
- **Base Mounting**

OPTIONAL WIRE ROPE LENGTHS

- **Wire ropes are sold separately**
20m and 13m supplied as standard (see below)
other lengths supplied as required

SPECIFICATIONS	1200G	1200S	1800G	1800S	2600G	2600S
Rated Load 1st Layer	550Kg	440Kg	825Kg	660Kg	1200Kg	960Kg
Working Load 3rd Layer	392kg	314kg	562kg	450kg	844kg	675kg
Max Rope Storage with free board	20m at recommended \emptyset				13m at recommended \emptyset	
Gear Ratio	4.1:1		5:1		9.8:1	
Drum \emptyset	50mm		60mm		76mm	
Wire Rope \emptyset recommended	5mm		7mm		8mm	
Net Weight approx.	3.3kg		8kg		11.5kg	

Use the affixes (G) or (S) to specify galvanised or stainless steel finish

NOTES

These winches must not be used for the movement of personnel and 5 wraps of wire rope must be maintained on the drum.

Data shown is approximate and intended as a guide only.

You are strongly advised to carry out a risk assessment before selecting a manual winch for any proposed application.

WARRANTY

Each new winch is guaranteed against defects in workmanship and material defects for a period of twelve months from date of purchase.

Wire ropes are not included under warranty.

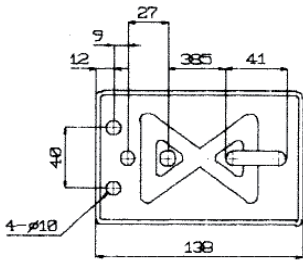

BHW 1200

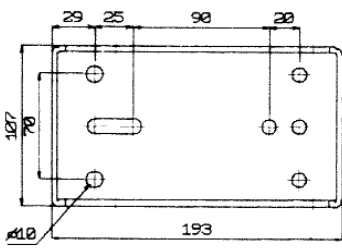
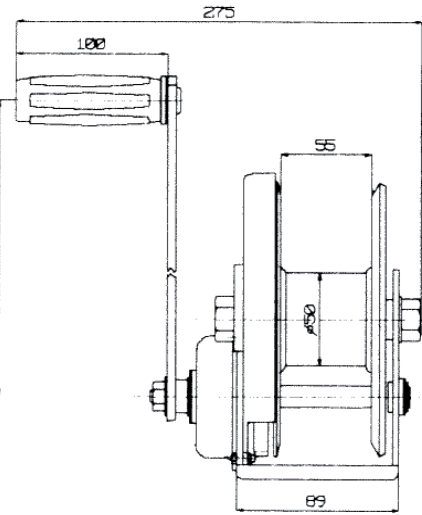
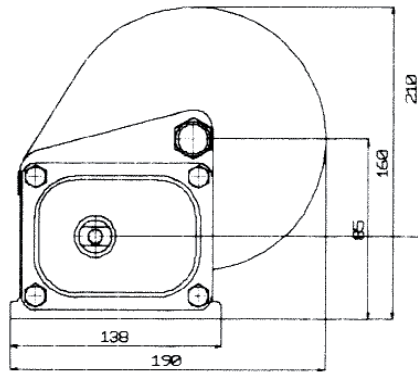

BHW 1800

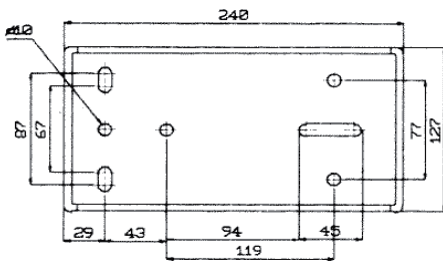
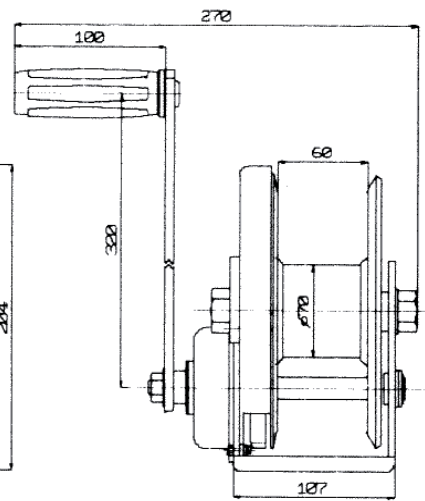
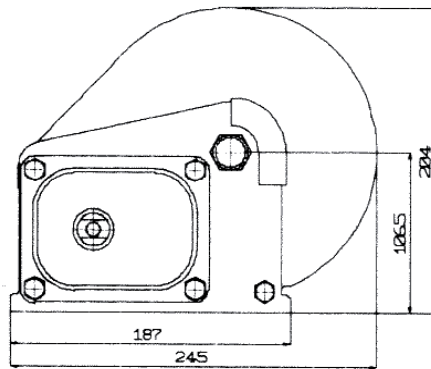

BHW 2600

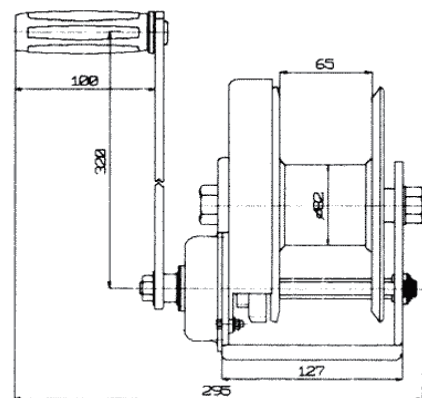
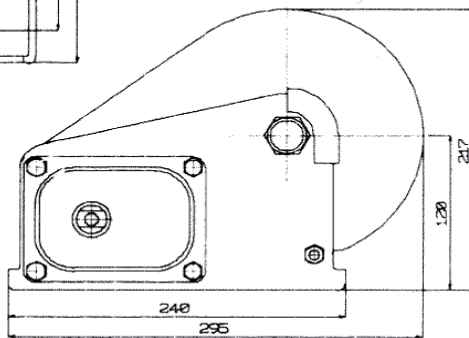

WM41/17.08.11