

# pewag winner Chain system in G10

Lifting



**Hardened shell –  
intelligent core**

**peTAG solution**



[dlhonline.co.uk](http://dlhonline.co.uk)

0161 223 1990

# Contents

## The pewag product range – tailor-made with safety in mind

For pewag, the focus always lies on service, quality and tradition. For centuries, the company has been continuously expanding its expertise in the field of chain systems and today it is among the global leaders in the industry. Innovation, safety and sustainability are key features of all our products.

Our lifting technology and load-securing chain system in G10 is currently the most comprehensive range on the market and customers all over the world appreciate the fact that we go far beyond standard market requirements. Application-specific, customised solutions and a great eye for detail are part and parcel of the pewag philosophy – in the past, in the present, and in future.



Full Member

Technical changes and misprints excepted.

<b>pewag group</b>	
Introduction of the pewag group	4-5
History and quality management	6
Business areas and the environment	7
Locations	8
<b>peTAG solution</b>	
peTAG solution	10-11
<b>Lifting accessories in G10</b>	
Benefits and information	12-23
<b>Chains in G10</b>	
Lifting chains	24-27
<b>Master links and sub-assemblies in G10</b>	
Master links and sub-assemblies in G10	28-55
<b>Accessories in G10</b>	
Accessories in G10	56-89
<b>Special accessories in G8</b>	
Special accessories in G8	90-101
<b>Spare parts</b>	
Spare parts	102-109
<b>User information</b>	
User information on pewag lifting accessories	110-116

# Welcome to the pewag group

**We are an internationally operating group of companies. Our track record goes back to the year 1479.**

## Mission Statement

**pewag group's Mission Statement expresses the goals of our actions as follows:**

With our joy for innovation, we strive to make all products of the pewag group the best in the respective markets. The high quality of our products and services as well as our employees' passionate dedication are the foundation to our pursuit of outstanding services and complete customer satisfaction.

## Principles of pewag group

### Leading in Quality

The values of our product brands are demonstrated by our first-class quality and innovations and are communicated consistently and coherently.

We anticipate market demands and changes in the environment and adapt our strategies, organizations and actions accordingly to satisfy our customers' needs through providing an optimal price-performance ratio: timely delivery, efficient and obliging service.

### Leading in Responsibility

We commit ourselves to careful treatment of the environment, by reducing the use of energy and raw materials, ensuring the longevity of our products and making them recyclable.

We value an open, honest and team-oriented work-style, which is based on transparent communication honoring ideas, opinions and experience of our employees as valuable inputs for our decision making process.

We strive for stable and fair partnerships with our employees, customers, suppliers and other business partners and take social aspects into consideration when making business decisions.

### Leading in Technology

We secure our technological strength by striving for product quality, constant improvements and innovations of products, as well as manufacturing processes.

We strive to be the best in product technology. This ensures that our customers always have optimal solutions available and that we expand and protect our market position.

### Leading in Economics

In all our processes we use due diligent business practices and efficiency and strive to improve these continuously.

In the long-term, we will continuously increase our economic performance to raise corporate value, achieve sustained growth and thus secure a successful future of the organization.

We are a modern group of companies which looks back to a tradition and experience of more than 500 years. Since our founding years, a lot has changed, but the values that made our success possible from the beginning remain.

**pewag group –  
Innovation. Quality. Partnership.**

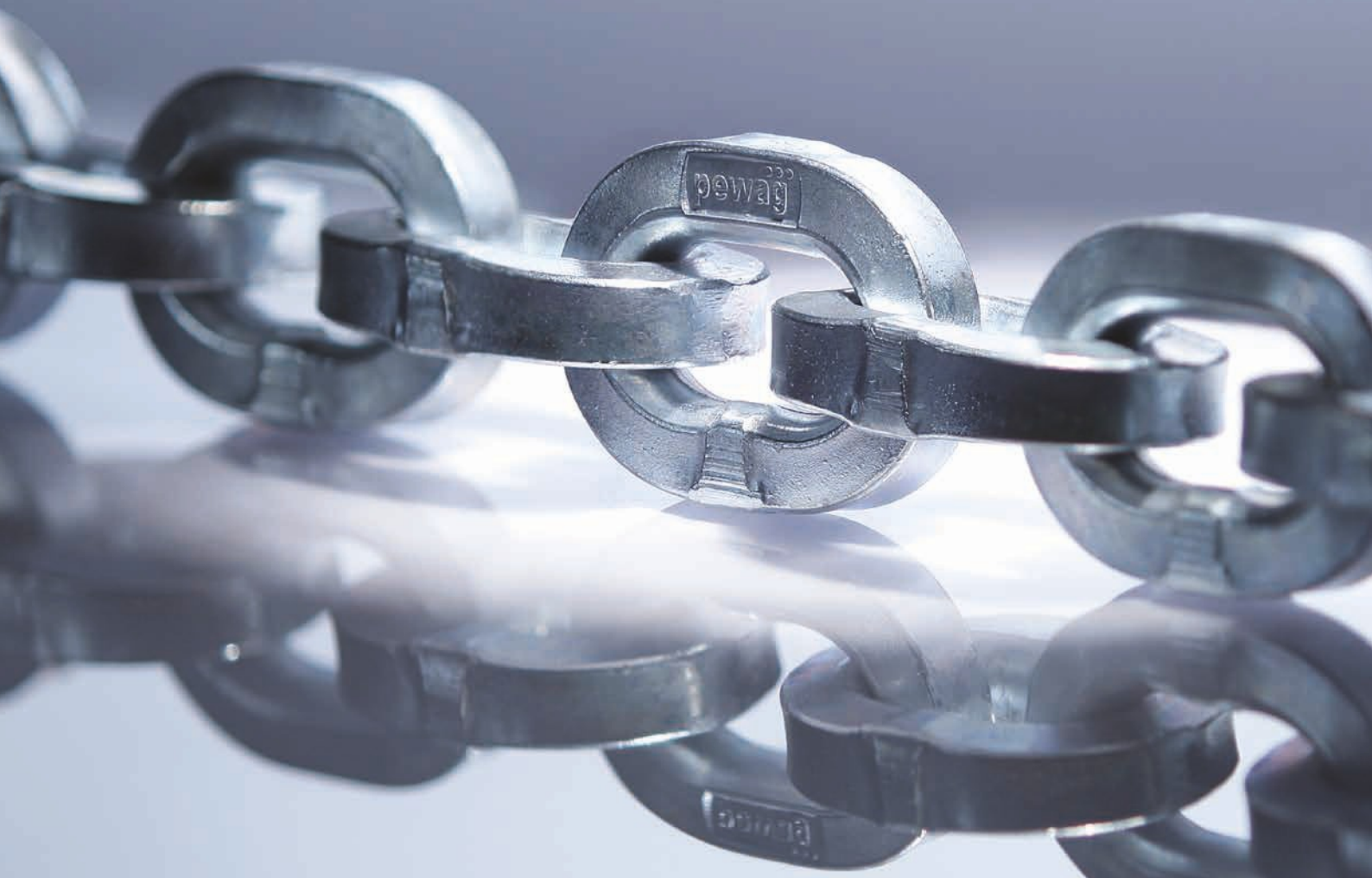

# History of the pewag group

# Quality management

## Advantage through tradition

The history of pewag group goes back to the 15<sup>th</sup> century and therefore makes us one of the oldest chain manufacturer worldwide. With our experience we are ready for the future.

### Timetable of important events

- 1479** First documented references of a forging plant in Brückl
- 1787** Foundation of a chain forge in Kapfenberg
- 1803** Foundation of a chain forge in Graz
- 1836** Establishment of an iron casting plant in Brückl
- 1912** Production of the first pewag snow chain
- 1923** Merger of plants in Graz and Kapfenberg – Creation of the name “pewag”
- 1972** Foundation of a sales company in Germany
- 1975** Foundation of a sales company in the USA
- 1993** Foundation of pewag austria GmbH
- 1994** Foundation of the first subsidiary in Czech Republic
- 1999** Acquisition of the Weissenfels Group
- 2003** Separation from the Weissenfels Group
- 2005** Reorganization into 2 groups:  
Schneeketten Beteiligungs AG Group – Snow Chains  
pewag austria GmbH Group – Technical Chains
- 2009** Acquisition of Chaineries Limousines S.A.S.
- 2012** Foundation of the first manufacturing company in the USA
- 2013/** Foundation of various international sales
- 2014** companies



Lithography forging plant Brückl 1855



Anchor chain forge 1878



Chain forgers 1956

## Our main goal is customer satisfaction.

In this instance, quality means that only those products and services are developed, manufactured and delivered which completely and without compromise satisfy the customer.

The pewag group’s quality policy, is underlined by the following basic principle: **“we supply high-end products and services to our customers that conform to the technical standards and requirements”**, can be summarised in the subsequent four points.

### Market-oriented Quality

In order to maintain and to widen the competitive position of the pewag group, the quality of finished goods and services must be consistent with the specifications of the customer and also with their expectations of one of the leading companies. No product should ever pose a danger to people or the environment.

### Economic Quality

As a profit-oriented company, quality is achieved by taking into consideration the material, personnel and financial resources; this means that we establish an appropriate best price/performance ratio for the customer within the acknowledged framework.

### Quality Responsibility

Stringent demands are placed on all employees to ensure high standards of quality. No matter what hierarchical level, all managers are in charge of managing quality. Every employee within the pewag group should be educated, motivated and instructed by the management team. It is important for promoting high quality awareness that the education and training of employees is at the forefront, as each employee is responsible for the quality of his/her own work.

For each of our employees, the statement **“QUALITY STARTS WITH ME”** must be true!

### Process-oriented Quality

The close interaction between sales, product development, production and customer service is regulated within the individual companies by fixed processes and activities, as well as responsibilities with the aim to reach and maintain the defined quality standards.



# Business areas

# Environment – we take responsibility

## Working with pewag products

The pewag group has a substantial and diverse spectrum of products and services.

Our range of products varies from traction chains for tires (snow chains for passenger cars, trucks and special-purpose vehicles, tire protection chains for mining vehicles) over different industrial chains to products for the do-it-yourself sector (light chains, belts, etc.)



**Segment A**  
Snow and forestry chains



**Segment B**  
Hoist and conveyor chains



**Segment C**  
Do-it-yourself



**Segment D**  
Engineering



**Segment F**  
Lifting and lashing chains and accessories



**Segment G**  
Tire protection chains



Our company's manufacturing location in Kapfenberg, Austria, has been used for iron and steel production for over 270 years. A second facility located in Brückl, Austria, was first documented in records dating back to 1479.

Based on this long manufacturing tradition, we take serious responsibility for our products, employees and the environment at all our international locations. Hence, one of our major concerns is to improve energy efficiency and, in doing so, to minimise energy consumption over a long period of time with the development of new production technologies. An important goal is to increase energy efficiency and consequently lower energy demand. Consequently, we develop our products to achieve longer product life-cycles and lower weight but simultaneously, increasing their working load capacities and the safety for our customers. We are committed to upholding all relevant energy and environmental standards by setting clearly defined goals and continually improving our performance. To achieve this goal, we use modern manufacturing technologies. An important step is to provide the necessary resources and to include our employees in the process. We are convinced that well-informed and motivated employees can actively participate in environmental conservation.

Wherever we are unable to avoid an environmental impact, we have set ourselves the goal to continually reduce our energy consumption, waste and environmentally harmful emissions. When purchasing new equipment, we strive to find the best and most efficient technical solution possible. It is important for us to promote the purchase of energy efficient products and services.

Our process-oriented management system regulates the documentation concerning all environmental relevant procedures. It also encompasses preventative measures for possible failures, as well as behavioural instructions for regular and/or extraordinary operational procedures. By systematically monitoring and assessing our environmental activities, we are quickly able to resolve deviances and to take corrective action. This process extends throughout the whole organisation to optimise all business processes. We strive to engage in an open dialogue with our customers, neighbours and authorities to inform them of our energy and environmental engagements.

Through specific communication we want to inform our customers about the environmental aspects of our products – specifically inform them about the longevity of our products. Through meaningful communication, we strive to motivate our suppliers and customers to think – in turn – about their environmental footprint and to put into practice similar environmental standards in their businesses.

# Customer proximity

## International presence

In the ambitious five-hundred year history pewag has evolved from a small and modest company to a global organization with several subgroups.

With 12 production and 40 sales and other locations on all five continents, pewag documented its claim as one of the world's leading chain manufacturers.

In addition to the numerous locations pewag as an international company relies on his capillary, strong, and professional partner network. These collaborations provide optimal customer service in currently more than 100 countries around the world.

## Production and sales locations

### Europe

Austria	pewag austria GmbH, Graz pewag austria GmbH, Kapfenberg pewag Schneeketten GmbH, Graz pewag Schneeketten GmbH, Brückl pewag engineering GmbH, Kapfenberg pewag austria Vertriebsgesellschaft mbH, Graz pewag Ketten GmbH, Klagenfurt pewag International GmbH, Klagenfurt
Germany	pewag Deutschland GmbH, Unna pewag Schneeketten Deutschland GmbH, Unna
France	pewag france SAS, Echirolles / Grenoble Chaineries Limousines SAS, Bellac
Italy	pewag italia srl, Andrian
Croatia	pewag d.o.o., Rijeka
The Netherlands	pewag nederland BV, Rijnsburg APEX International BV, Hillegom APEX Automotive BV, Hillegom
Poland	pewag polska Sp z.o.o., Buczkowice
Portugal	pewag Portugal – Comercio de Produtos e Equipamentos Industriais, Lda, Santo Antão do Tojal
Romania	pewag Romania SRL, Sibiu County
Russia	OOO "PEWAG", Moscow
Sweden	pewag sweden AB, Emmaboda
Slovakia	pewag Slovakia sro, Nováky
Czech Republic	pewag Czech sro, Vamberk Řetězárna Česká Třebová sro, Vamberk pewag sro, Vamberk pewag Czech sro, Česká Třebová peform Chrudim sro, Chrudim

### Europe

Ukraine	TOV pewag Ukraine GmbH, Lviv
---------	------------------------------

### North America

USA	pewag Inc, Bolingbrook, Illinois pewag Inc, Rocklin, California pewag Traction Chain Inc, Pueblo, Colorado
Canada	pewag Canada Inc., Mississauga
Mexico	pewag Mexico SA de CV, Mexico

### South America

Brazil	Helevar Comércio e Importação de Produtos Metalúrgicos Ltda., Porto Alegre
Colombia	pewag Columbia S.A.S, Medellin

### Africa

South Africa	pewag chain south africa (pty) ltd., Rivonia
--------------	--

### Australia

Australia	pewag australia Pty Limited, Barrack Heights
-----------	--

### Asia

India	pewag India Private Limited, Bangalore
-------	--



pewag group presents  
itself on the internet. More ...  
[www.pewag-group.com](http://www.pewag-group.com)  
[www.pewag.com](http://www.pewag.com)

**pewag group –  
Innovation. Quality. Partnership.**



## pewag chains together

The peTAG solution enables cross-company, flexible servicing and administration of a wide range of different objects.

### peTAG solution

The intelligent solution for unambiguous object identification, data transfer without media breaks, easy servicing of objects, safe document archiving, efficient interaction with partner businesses and much more.

### peTAG info

Smart, free-of-charge access to product-specific information via mobile web.

### peTAG manager

Watch your PC and mobile devices work hand in hand with this adaptable, high-performance platform in any work environment.



# peTAG solution



## peTAG solution Keyfacts



### Intelligent software

User-specific adaptation of object data, testing processes and steps. Automates the creation, sending and archiving of test reports. Sophisticated authorisation concept.



### Save time & money

Efficient documentation of work processes, thus simplified daily workflows. Data exchange without media breaks, fault-free data communication.



### Mobile solution

Direct, location-independent data access (e.g. load capacity, safety information, latest test reports etc.) Smart servicing of objects via mobile app. Offline availability.



### Linked-up partnerships

Straightforward exchange and efficient interaction between service providers, merchants and customers. Improved service and data quality. Increased satisfaction and loyalty.



### Always up to date

Access to the latest product data and information, overview of all test data, documentation of test procedures. Traceability of object history.



# Lifting accessories in G10

## Benefits and information

### Content

Lifting chains in G10 quality	14
pewag lifting chain	14-15
pewag winner core data	15
pewag winner chain marking	15
pewag winner identification	16
Novelty: rectangular lifting identification tags	16
Load capacities	18-19
Exceptional conditions of use	20
Examples of order text	20-21
Standard sling types	22-23





## Lifting chains in G10 quality – benefits that outweigh the rest.

pewag is among the world's best manufacturers of lifting chains – for a good reason, as our products are the result of a responsible development process that focuses on user-friendliness and safety. These features are clearly measurable and form the basis of the pewag product development and manufacturing process, where only the best results count!

- 25 % more load capacity compared to G8

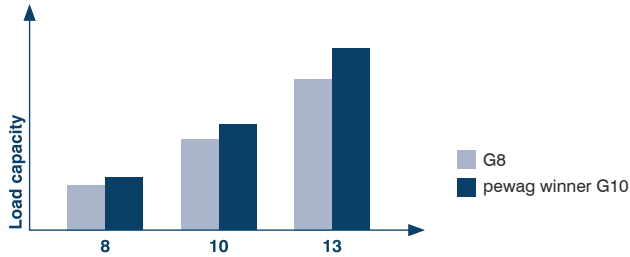

Load capacity	Previous chain Ø	pewag winner chain Ø
3,550	10	8
5,600	13	10
9,500	16	13

- Simplified handling thanks to a 30 % weight reduction

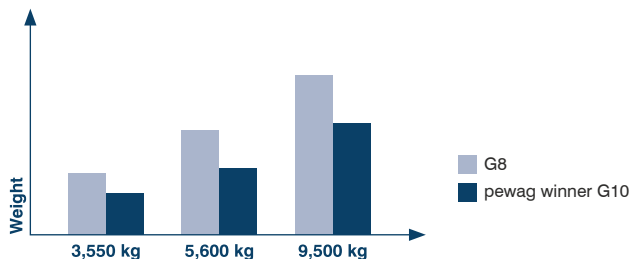

Load capacity	Previous chain weight	pewag winner chain weight	% weight reduction
3,550	16.20 kg	11.00 kg	32 %
5,600	27.60 kg	17.60 kg	36 %
9,500	42.20 kg	29.60 kg	30 %

- Attractive price/performance ratio thanks to the small price differential compared to grade 8
- One dimension smaller than grade 8 slings, for many load ranges – thus providing excellent value
- Extended service life due to higher wear resistance
- WIN 400 Easy identification – each link is marked with “W”  
WIN 200 Easy identification – each link is marked with “10”
- Code on chain and component ensures traceability of all manufacturing data
- Distinctive oval-shaped tags with precise information helps avoid confusion with grade 8

- High-visibility orange powder-coating for simple visual identification
- Largest range of components in special grade 10 quality – for 11 chain dimensions
- Fastest and simplest assembly of slings thanks to VXXW set with unique shortening element



- Additional safety feature compared to shortening claws, thus reducing risks resulting from improperly attached chains of our shortening hooks
- Easier and faster annual inspection as fewer components are used
- Compatible with our grade 8 range – used slings are easy to repair. NOTE: Grade 10 components may be used to repair G8, but not at an increased load capacity!
- First company to offer parallel hooks with 100 % load capacity – shortening of the sling chain does not require a reduction in load caused by shear effect of the hook!
- 3 assembly systems of slings: welded, Connex and Clevis system
- Pioneer: pewag were the first to sell G10 lifting chains and have a wealth of experience in this field
- Quality-approved European production by an ISO 9001 certified company
- Worldwide distribution network – smooth supply of spare and replacement parts
- All components comply with EN 1677-1, -2, -3 or -4
- A true-as-steel bonus: The pewag winner 400 chain meets the EN 818-2 with higher working load limit resp. PAS 1061 up to 16 mm and Machinery Directive 2006/42/EG

## pewag lifting chains – environmentally friendly, resource-preserving, strong.

True-as-steel quality management principles best explain why pewag is now offering even more benefits for lifting chains. For instance, ISO 14001 certification is being

rigorously implemented for the G10 lifting chains, resulting in significantly lowered energy and material consumption during manufacturing, thus preserving raw materials – an environmentally friendly approach throughout! And the reduced amount of materials used also means that less material has to be recycled.

## Core data of the pewag winner range – winner by name, winner by nature.

- **Top ranking:**  
**pewag winner 200** – meets the requirements of ASTM A973/A973M-01 and of EN 818-2 but with higher load capacity (however admissible operating temperature of 200 °C max.) and 2006/42/EG Machinery Directive.  
**Chain quality of pewag winner 400** meets the EN 818-2 with higher working load limit resp. PAS 1061 up to 16 mm and Machinery Directive 2006/42/EC
- **Stress at load capacity limit:** 250 N/mm<sup>2</sup>
- **Test stress:** 625 N/mm<sup>2</sup> – equals 2.5 times the load capacity
- **Breaking stress:** 1,000 N/mm<sup>2</sup> – equals 4 times load capacity
- **Breaking elongation:** min. 20 %
- **Bending according to EN 818-2 or PAS 1061:** 0.8 x nominal diameter
- **Admissible operating temperature:**  
 pewag winner 200 – 200 °C max.  
 pewag winner 400 – up to 380 °C
- **Quality grade stamps**  
**pewag winner 200:** 100 at a spacing of approx. 300 mm till 16 mm chain (other 0.9 m) and 10 additionally on the back of each link  
**pewag winner 400:** 8W at a spacing of approx. 300 mm up to 16 mm chain (other 900 mm) and W on the back of each link  
**Components – 10**  
**pewag winner 400 PAS:** 10 at a spacing of approx. 300 mm  
**Components – 10**
- **Manufacturer's name or symbol on the chain and components:** PW or pewag
- **Surface:**  
**pewag winner 200:** shot-blasted and clear coated  
**pewag winner 400:** blue painted  
**Components:** orange powder-coated  
**Welded system:** blue painted
- **Compatibility:**  
 pewag winner chains and components may be combined by a competent person under consideration of the manufacturer specifications with all grade 8 components that meet the requirements of EN 818 and EN 1677. Furthermore, the pewag winner chains may be combined with all competitor chains and components that are compatible with EN 818

and EN 1677 qualified items. Please note that the products cannot be combined with items that do not comply with EN 818 or EN 1677! The maximum working load capacity of the overall system is always defined by its weakest part.

Only original pewag spare parts (e. g. pins and bolts, safety catches, etc.) may be used for pewag products, subject to inspection and approval by the competent person.

- **Product characteristics** for stress crack corrosion are equal to those of grade 8

All dimensions given in this catalog are nominal dimensions. Depending on the manufacturing process they are subject to various manufacturing tolerances. Please contact our customer service if required.

## pewag winner chain markings, old and new.

pewag winner 400 chain with old chain markings and the usual outstanding safety characteristics:

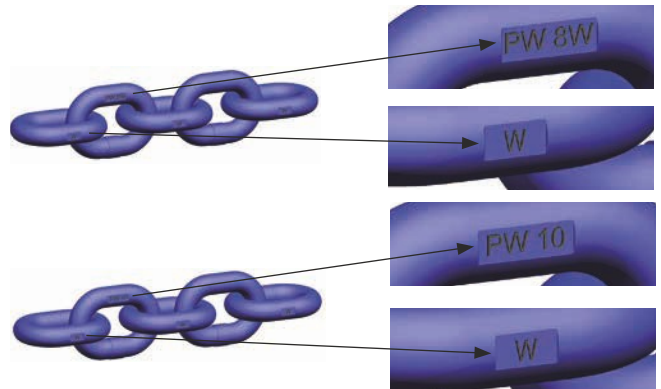

pewag winner 400 chain with new chain markings and the usual outstanding safety characteristics:

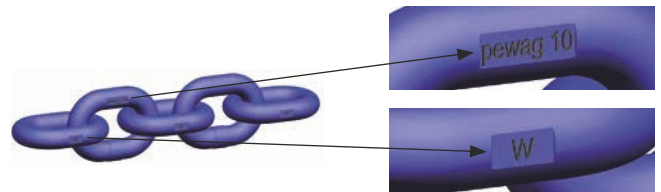

WIN 200 chain with old chainmarking:

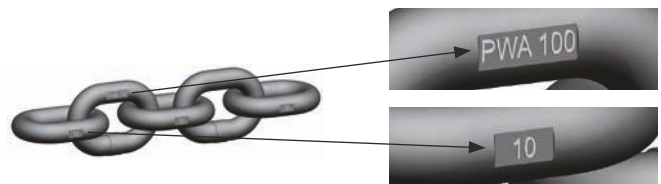

WIN 200 chain with new chainmarking:

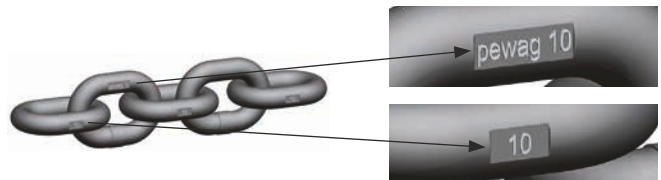

## pewag winner identification tags – fast and easy to read.

All necessary technical data is attached on the chain ID tag. For easier identification of the chain grade and quality, a separate ID tag is used.

### pewag winner 200 – old load capacity tags



The pewag winner 200 load capacity tag.

### pewag winner 400 – old load capacity tags



The pewag winner 400 load capacity tag.

## Novelty: rectangular load capacity tag.

pewag is always striving to develop its products further. The shape of the load capacity tags was changed to a rectangular design that offers numerous benefits to the user, thus taking our idea of safety yet one step further.

The tags are made from rust-proof material and linked to the sling with a rust-proof, quick-release fastener, thus considerably increasing user safety.

This will eliminate once and for all an error that happened fairly often in the past: As all standard documents for lifting chains describe ID tags where the number of corners correspond to the grade category of the lifting chain, users frequently made the mistake of estimating the load capacity of the chain based on this information, without paying attention to the actual markings on the tag. However, standards only ever describe the minimum requirements that a product must comply with and can always be exceeded.

The rectangular load capacity tags prevent this mistake from happening and offer the following benefits to the user:

- Prevention of incorrect assessment of the load capacity as looking at the tag prior to each lifting operation becomes unavoidable

- When the marking is not observed, the lifting chain will be classed as a maximum grade
- Corrosion-resistant: therefore resistant to solvents, acids, caustics and their vapours
- Easily replaceable due to the rustproof cable with quick-release fastener
- All information is engraved, allowing for customer-specific markings
- Pre-stamped years for the periodic inspections make it immediately apparent when the last inspection took place
- For periodic inspections, only the month must be stamped

### pewag winner 400 – new load capacity tag



Safety first was the guiding principle behind the development of the new pewag winner 400 load capacity tag



# pewag winner G10 – in safety lies strength.







[dlhonline.co.uk](http://dlhonline.co.uk)

0161 223 1990



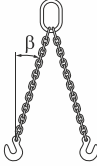
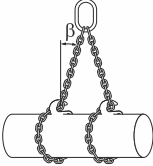

## pewag winner load capacities

The load capacities listed are maximum values of the various sling types, stated according to the standard (Uniform Load) method of rating.

Safety factor 4	I-leg chains		II-leg chains				III- + IV-leg chains	
								
Angle of inclination $\beta$	-	-	0° – 45°	45° – 60°	0° – 45°	45° – 60°	0° – 45°	
Load factor	1	0.8	1.4	1	1.12	0.8	2.1	
Code	d	Load capacity [kg]						
WIN 5	5	1,000	800	1,400	1,000	1,120	800	2,000
Ni 5 G8	5	800	640	1,120	800	900	640	1,600
WIN 6	6	1,400	1,120	2,000	1,400	1,600	1,120	3,000
Ni 6 G8	6	1,120	900	1,600	1,120	1,250	900	2,360
WIN 7	7	1,900	1,500	2,650	1,900	2,120	1,500	4,000
Ni 7 G8	7	1,500	1,200	2,120	1,500	1,700	1,200	3,150
WIN 8	8	2,500	2,000	3,550	2,500	2,800	2,000	5,300
Ni 8 G8	8	2,000	1,600	2,800	2,000	2,240	1,600	4,250
WIN 10	10	4,000	3,150	5,600	4,000	4,250	3,150	8,000
Ni 10 G8	10	3,150	2,500	4,250	3,150	3,550	2,500	6,700
WIN 13	13	6,700	5,300	9,500	6,700	7,500	5,300	14,000
Ni 13 G8	13	5,300	4,250	7,500	5,300	5,900	4,250	11,200
WIN 16	16	10,000	8,000	14,000	10,000	11,200	8,000	21,200
Ni 16 G8	16	8,000	6,300	11,200	8,000	9,000	6,300	17,000
WIN 19	19	14,000	11,200	20,000	14,000	16,000	11,200	30,000
Ni 19 G8	19	11,200	8,950	16,000	11,200	12,500	8,950	23,600
WIN 22	22	19,000	15,000	26,500	19,000	21,200	15,000	40,000
Ni 22 G8	22	15,000	12,000	21,200	15,000	17,000	12,000	31,500
WIN 26	26	26,500	21,200	37,500	26,500	30,000	21,200	56,000
Ni 26 G8	26	21,200	16,950	30,000	21,200	23,700	16,950	45,000
WIN 32	32	40,000	31,500	56,000	40,000	45,000	31,500	85,000
Ni 32 G8	32	31,500	25,200	45,000	31,500	35,200	25,200	67,000

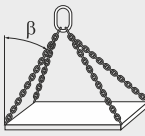
If the chain slings are used in severe conditions (e.g. high temperature, asymmetric load distribution, edge load, impact/shock loads), the maximum load capacity values in the table must be reduced by the load factors specified on page 20.

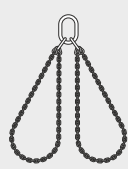

Please also note the user information on different conditions of use and their effects on the load capacity values!

III- + IV- leg chains	IV- leg chains with load distributor		Endless chain sling	Single lifting sling		Double lifting sling	
							
45° – 60°	0° – 45°	45° – 60°	-	0° – 45°	45° – 60°	0° – 45°	45° – 60°
1.5	2.8	2	1.6	1.4	1	2.1	1.5
1,500	2,800	2,000	1,600	1,400	1,000	2,000	1,500
1,180	2,240	1,600	1,250	1,120	800	1,600	1,180
2,120	4,000	2,800	2,240	2,000	1,400	3,000	2,120
1,700	3,150	2,240	1,800	1,600	1,120	2,360	1,700
2,800	5,300	3,750	3,000	2,650	1,900	4,000	2,800
2,240	4,000	3,000	2,500	2,120	1,500	3,150	2,240
3,750	7,100	5,000	4,000	3,550	2,500	5,300	3,750
3,000	5,600	4,000	3,150	2,800	2,000	4,250	3,000
6,000	11,200	8,000	6,300	5,600	4,000	8,000	6,000
4,750	8,500	6,300	5,000	4,250	3,150	6,700	4,750
10,000	19,000	13,200	10,600	9,500	6,700	14,000	10,000
8,000	14,000	10,600	8,500	7,500	5,300	11,200	8,000
15,000	28,000	20,000	16,000	14,000	10,000	21,200	15,000
11,800	22,400	16,000	12,500	11,200	8,000	17,000	11,800
21,200	39,200	28,000	22,400	20,000	14,000	30,000	21,200
17,000	-	-	18,000	16,000	11,200	23,600	17,000
28,000	53,200	38,000	30,000	26,500	19,000	40,000	28,000
22,400	-	-	23,600	21,200	15,000	31,500	22,400
40,000	74,200	53,000	42,500	37,500	26,500	56,000	40,000
31,500	-	-	33,500	30,000	21,200	45,000	31,500
60,000	-	-	63,000	56,000	40,000	85,000	60,000
47,500	-	-	50,000	45,000	31,500	67,000	47,500

## Exceptional conditions of use

Even the highest-quality products will lose some of their load capacity if used at high temperatures, as a consequence of asymmetric load distribution, edge loading, shock/impact loading or other exceptional conditions of use. Please consult the user information for details.

The following circumstances are considered exceptional conditions of use as outlined above:

<b>Temperature</b>	-40 °C – 200 °C	above 200 °C – 300 °C	above 300 °C – 380 °C
<b>Load factor pewag winner 200</b>	1	not permissible	not permissible
<b>Load factor pewag winner 400</b>	1	0.9	0.75
<b>Asymmetric load distribution</b>	The WLL has to be reduced by at least 1 leg. In case of doubt only consider 1 leg as load-bearing.		
<b>Edge load *</b>	R = larger than 2 x d*	R = larger than d*	R = smaller than d*
			
<b>Load factor</b>	1	0.7	0.5
<b>Shock</b>	slight shocks	medium shocks	strong shocks
<b>Load factor</b>	1	0.7	not permissible

\* d = dia. of chain

## Sample order text for pewag winner sling types

Here you will find some examples that show what an order of a fully assembled and commercially available pewag winner G10 chain system could look like, clearly labelled and with all components and measurements.

What you see here is a pewag winner 400 II-leg chain sling, 13 mm, with shortening device and hook. Length: 3000 mm.

**Clevis system:**

**WIN 13 400 II VXKW – KHSW 3000**

Nominal diameter	Short designation	Number of legs	Master link	End hook	Length [mm]
13	400 II	2	VXKW	KHSW	3000

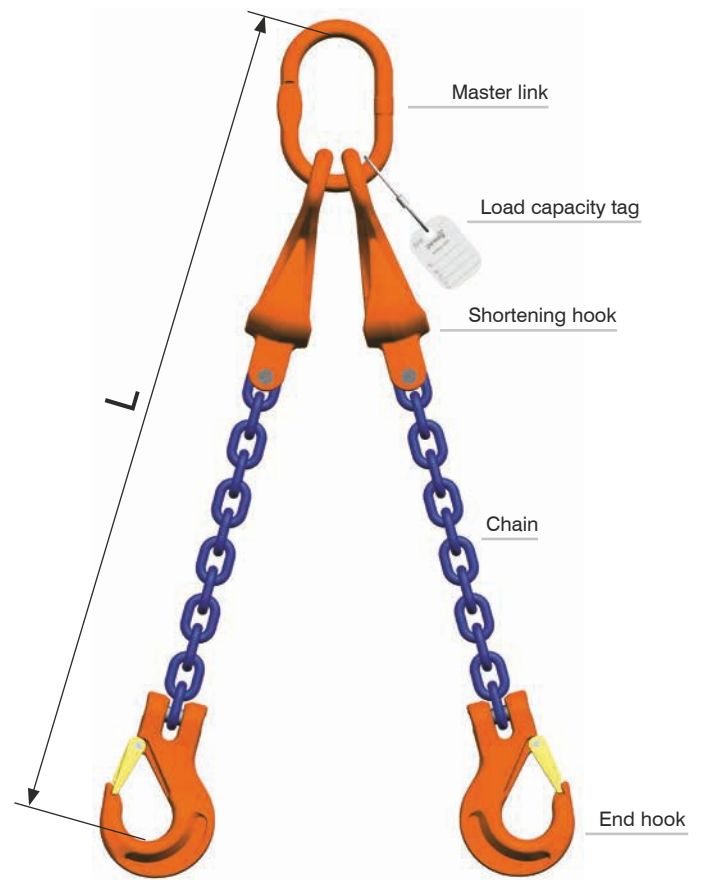

## Sample order text

### Connex System:

### WIN 13 400 II VXKW – HSW 3000 Connex

Nominal diameter	Short designation	Number of legs	Master link	End hook	Length [mm]
------------------	-------------------	----------------	-------------	----------	-------------

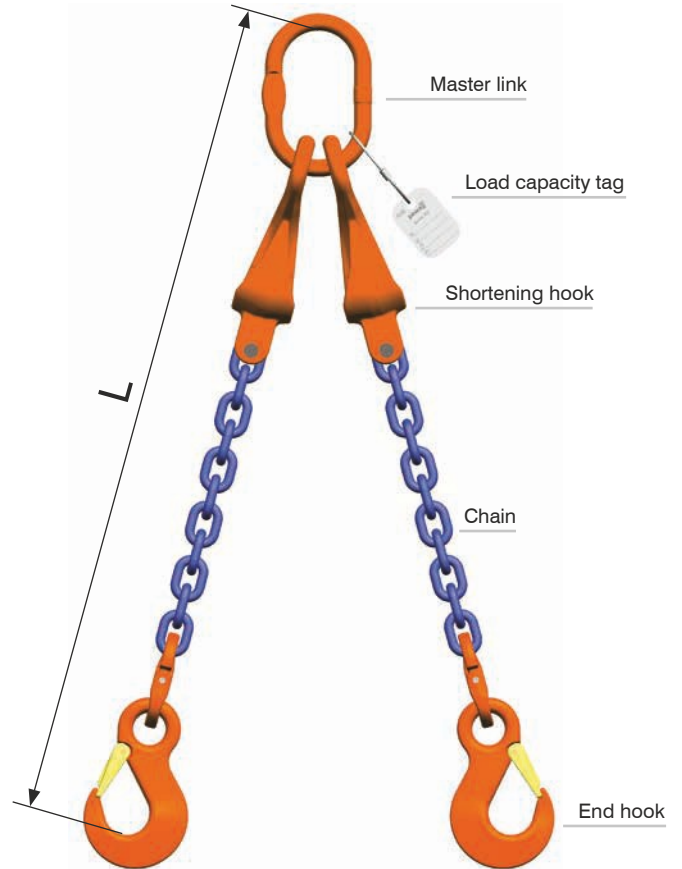

### Welded system:

### WIN 13 400 II VXKW – HSW 3000

Nominal diameter	Short designation	Number of legs	Master link	End hook	Length [mm]
------------------	-------------------	----------------	-------------	----------	-------------

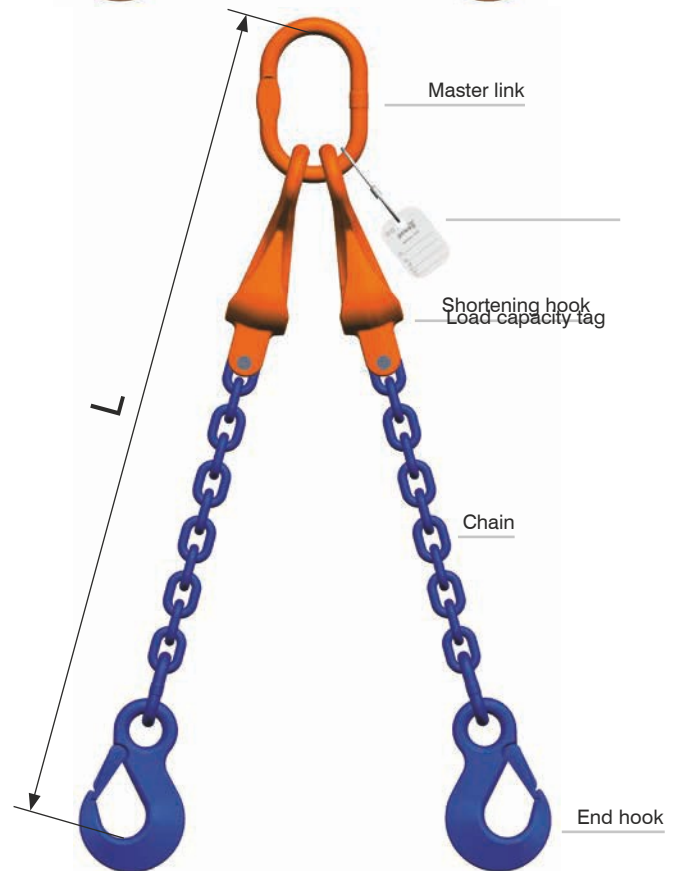

## pewag winner standard sling types – perfect in the original!

User reliability also comes first for those elements used as lifting components in our standard slings. To a large extent, these can also be manufactured and supplied in other assembly systems to the ones shown here.

If you require a sling type that is not listed here, please submit a small sketch indicating the required type.

Important: Especially if you handle the assembly yourself, make sure that only pewag winner original parts are used! The usual tolerance of length "L" is +2 chain pitches.

The sling designation system is the same as that of G8. The additional "W" in the code of the individual parts points to the higher quality grade.

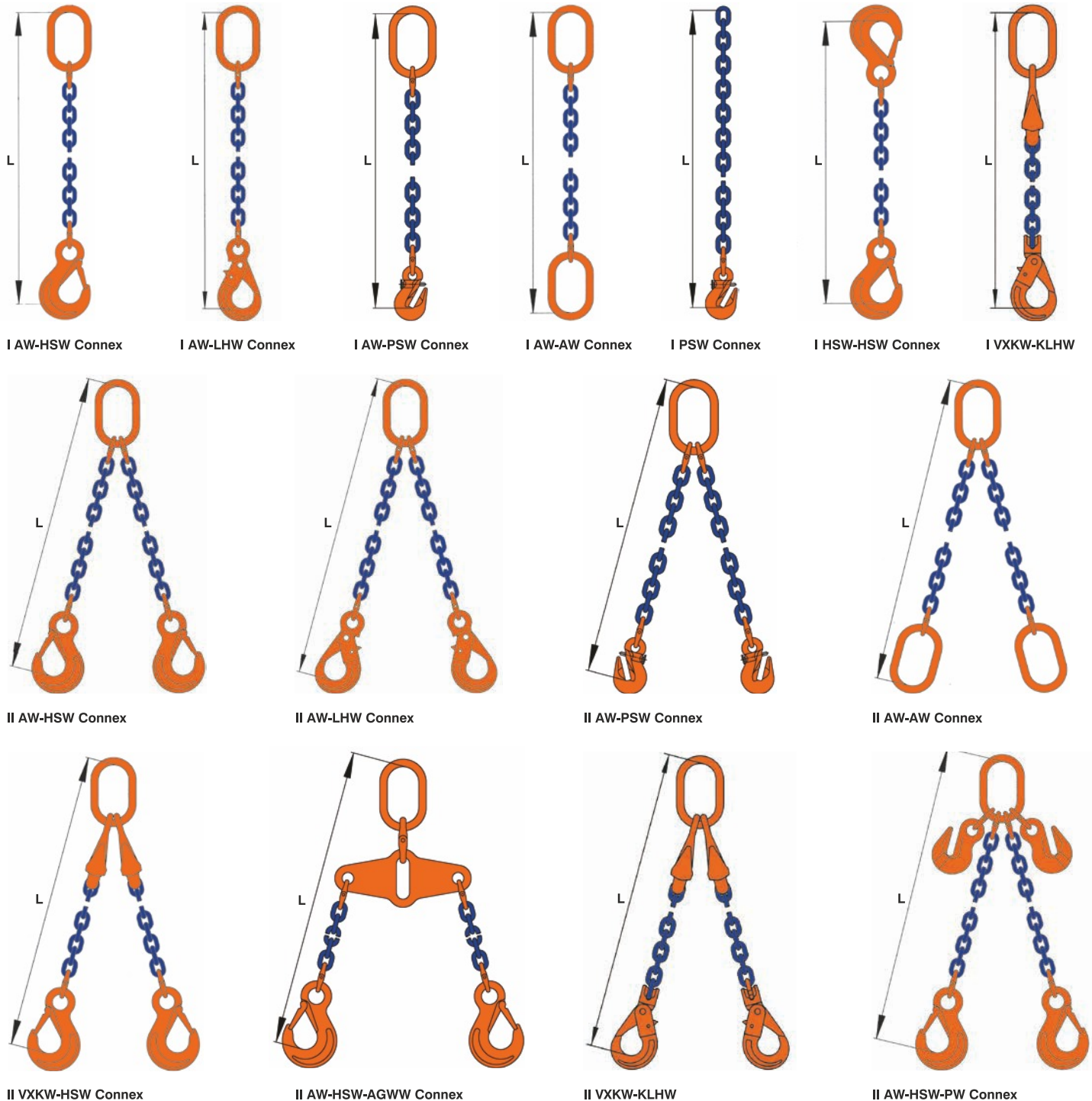

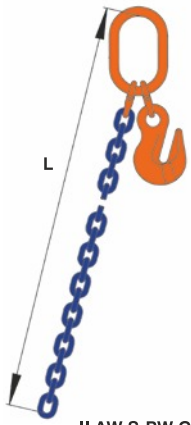

II AW-S-PW Connex

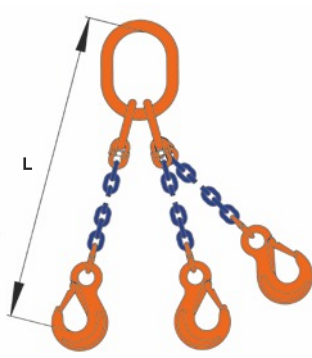

III VW-HSW Connex

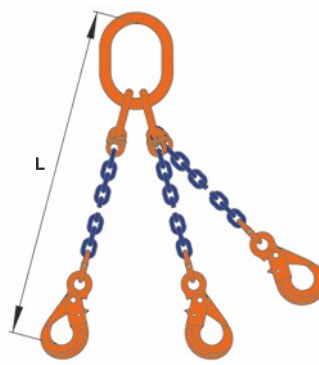

III VW-LHW Connex

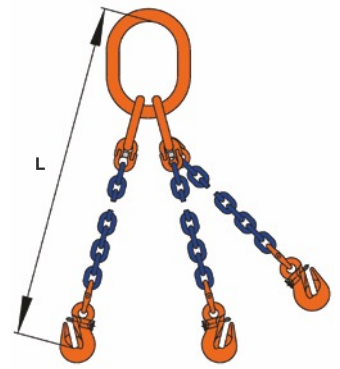

III VW-PSW Connex

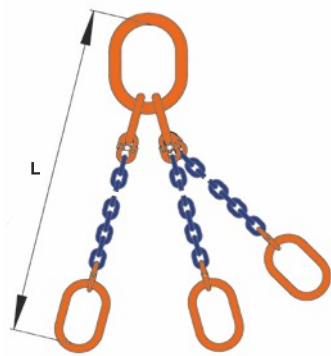

III VW-AW Connex

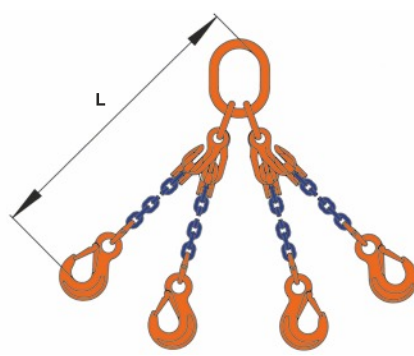

IV VXKW-HSW Connex

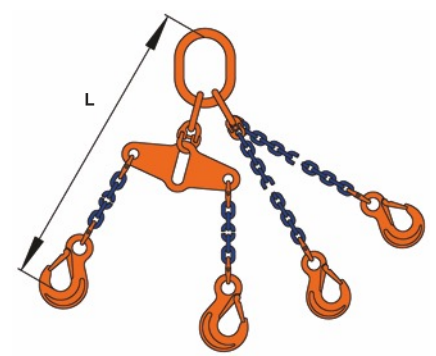

IV VW-HSW-AGWW Connex

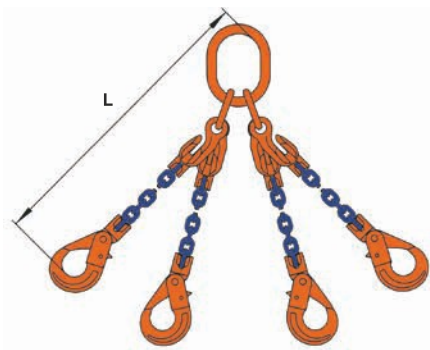

IV VXKW-KLHW

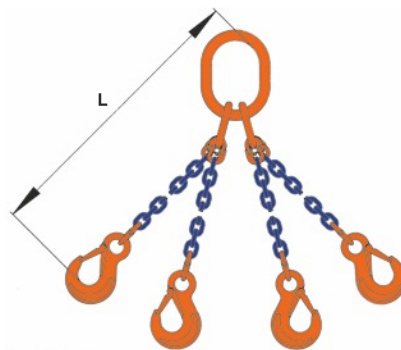

IV VW-HSW Connex

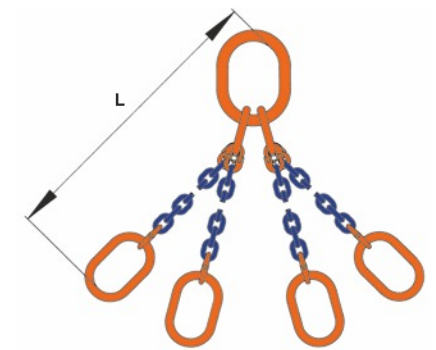

IV VW-AW Connex

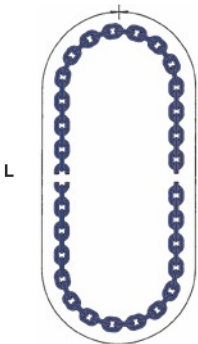

S

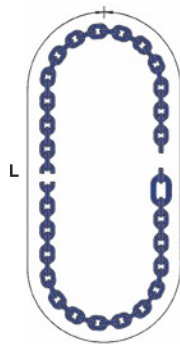

SK (up from dimension 8)

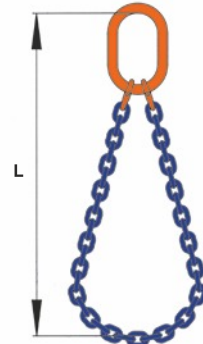

II AW-S Connex

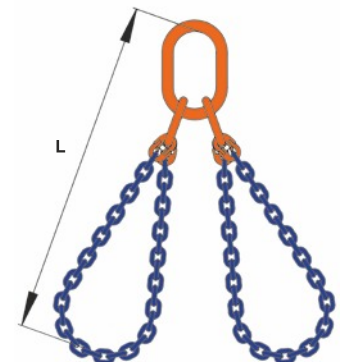

IV VW-S Connex

# Chains in G10

## Product overview

### Content

Lifting chains pewag winner 400	26
Lifting chains pewag winner 200	27

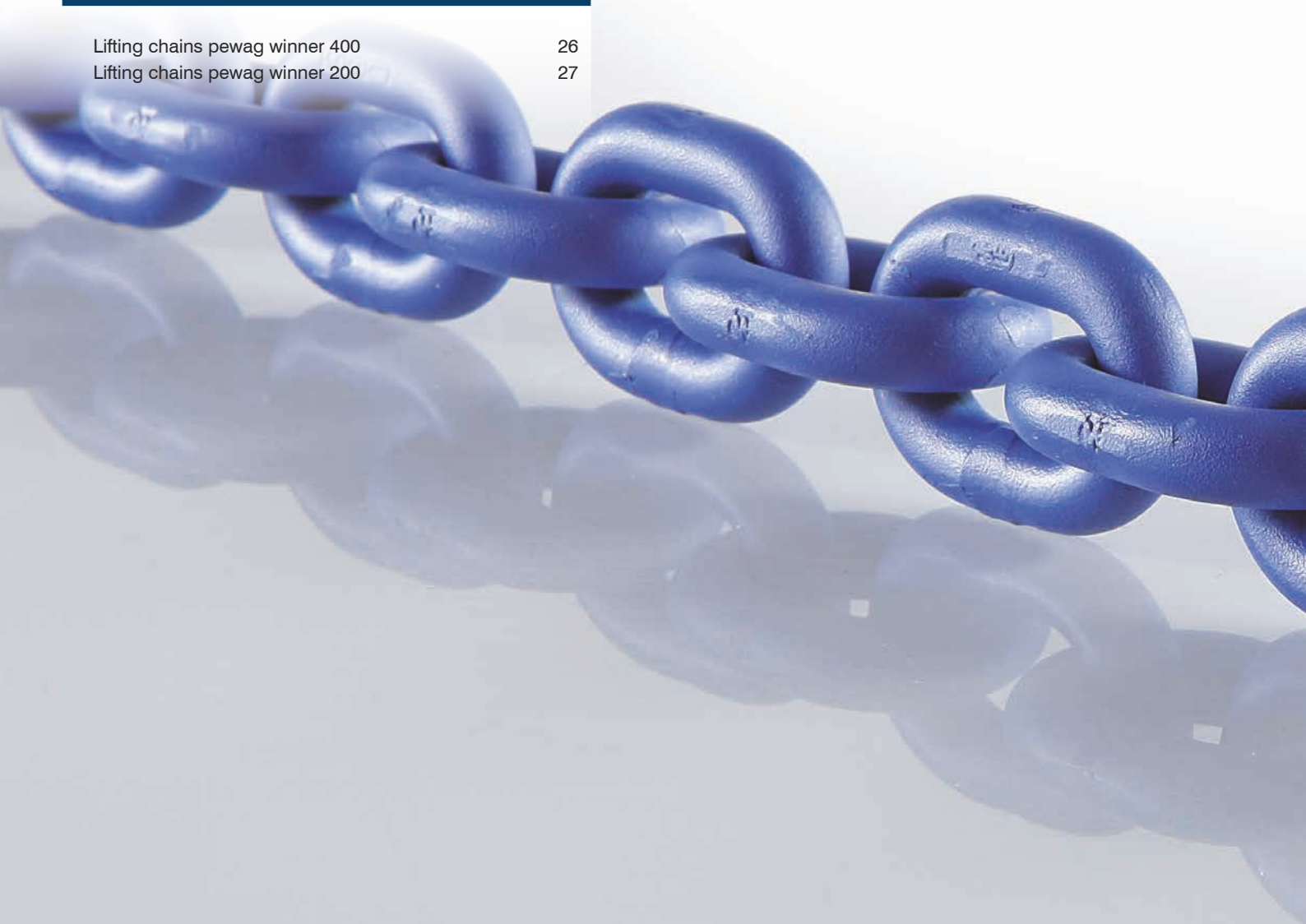





# pewag winner 400 Lifting chains

## Top performance as a matter of course.

These grade 10 high-duty chains comply with EN 818-2 at a higher load capacity. They are manufactured according to EN 818-2 with mechanical values for G10/PAS 1061. BG-approved and therefore ideal for the assembly of chain slings and the lifting and transporting of loads.

These round-steel chains fit perfectly in lifting and chain lashing chains and withstand operating temperatures of -40 up to +380 °C.

The standard surface is blue and the chains are available in dimensions from 5 to 32 mm. For more information, please refer to the full operating manual.

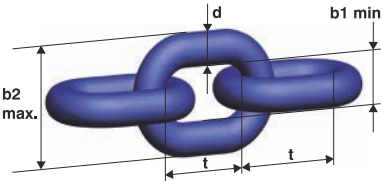

	Code	Nominal diameter [d]	Standard delivery length [m]	Pitch [t]	Inside width [b1 min.]	Outside width [b2 max.]	Load capacity [kg]	Breaking force [kN]	Weight [kg/m]
<b>WIN 400 Lifting chain</b> 	WIN 5 400	5	50	16	8	19	1,000	39.30	0.61
	WIN 6 400	6	50	18	9	22	1,400	56.50	0.96
	WIN 7 400	7	50	21	10	25	1,900	77	1.20
	WIN 8 400	8	50	24	11	29	2,500	101	1.57
	WIN 10 400	10	50	30	14	36	4,000	157	2.46
	WIN 13 400	13	50	39	18	47	6,700	265	4.18
	WIN 16 400	16	25	48	22	58	10,000	402	6.28
	WIN 19 400	19	25	57	27	69	14,000	567	8.92
	WIN 22 400	22	25	66	30	79	19,000	760	11.88
	WIN 26 400	26	25	78	35	94	26,500	1,060	16.18
	WIN 32 400	32	15	96	43	115	40,000	1,610	24.10

## pewag winner 200 Round steel chains

### As secure as the pro's.

These high-duty chains in G10 are manufactured according to EN 818-2, modified, and comply at a higher load capacity. Please notice that they are not allowed for lifting chains in Austria.

These round-steel chains are particularly suitable in lifting and chain lashing chains and withstand operating temperatures of 200 °C.

The standard surface is blasted and clear painted. For further information, please consider the user information.



	Code	Nominal-diameter [d]	Standard delivery length [m]	Pitch [t]	Inside width [b1 min.]	Outside width [b2 max.]	Load capacity [kg]	Breaking force [kN]	Weight [kg/m]
<b>WIN 200 Round steel chain</b> 	WIN 5 200	5	100/50	16	8	19	1,000	39.3	0.61
	WIN 6 200	6	200/50	18	9	22	1,400	56.5	0.96
	WIN 7 200	7	300/50	21	10	25	1,900	77	1.20
	WIN 8 200	8	250/50	24	11	29	2,500	101	1.57
	WIN 10 200	10	150/50	30	14	36	4,000	157	2.46
	WIN 13 200	13	100/50	39	18	47	6,700	265	4.18
	WIN 16 200	16	100/25	48	22	58	10,000	402	6.28
	WIN 19 200	19	50/25	57	27	69	14,000	567	8.92
	WIN 22 200	22	50/25	66	30	79	19,000	760	11.88
	WIN 26 200	26	25	78	35	94	26,500	1,060	16.18
	WIN 32 200	32	20	96	43	115	40,000	1,610	24.10

# Master links and sub-assemblies in G10

## Product overview

### Contents

Master links	30-31
Transition links	32
Four-leg assemblies	33-35
Oversize master link assemblies	36-38
Master link assemblies	39-40
Clevis master sets	41-52
Oversize clevis master sets	53-55





# pewag AW Master link

## Perfection from start to finish.

This master link is ideally suited for pewag Connex and as a component in the welded system. It may also be used as a master link for I-leg chain A I and A II.

For II- and IV- leg chains it can only be used in conjunction with BW transition links in VW IV-leg assemblies. Ideal for simple, speedy assembly of I- and II-leg chain slings using Connex connecting elements. May also be used as a master link in welded systems- assembly has never been easier! Also suitable as an end link for A I classifications. See table below for the maximum crane hook size as specified by DIN 15401.

The flattened section enables universal connecting options - an important benefit of this high-grade link. Links are manufactured according to EN 1677-4 with mechanical values for G10. BG-approval, CE-markings and full operating manual available.

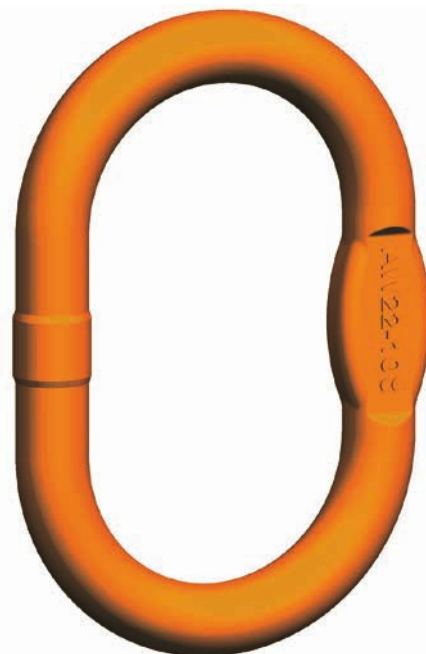

AW Master link	Code	Load capacity 0 – 45° <sup>1</sup> [kg]	Can be used up to single hook acc. to DIN 15401	d	t	w	s	Weight [kg/pc.]	Master link for chain Ø	
				[mm]	[mm]	[mm]	[mm]		I-leg AW I [mm]	II-leg AW II [mm]
	AW 10	1,400	no. 1.6	10	80	50	10	0.14	5	5
	AW 13	2,300	no. 2.5	13	110	60	10	0.34	6+7	6
	AW 16	3,500	no. 2.5	16	110	60	14	0.58	8	7
	AW 18	5,000	no. 5	19	135	75	14	0.92	10	8
	AW 22	7,600	no. 6	23	160	90	17	1.59	13	10
	AW 26	10,000	no. 8	27	180	100	20	2.46	16	13
	AW 32	14,000	no. 10	33	200	110	26	4.04	19	16
	AW 36	25,100	no. 16	36	260	140	29	6.22	22	19
	AW 45	30,800	no. 25	45	340	180	-	12.82	26	22
	AW 50	40,000	no. 32	50	350	190	43	16.60	32	26
	AW 56	64,000	no. 32	56	400	200	-	23.30	-	32
	AW 72	85,000	no. 50	70	460	250	-	43.11	-	-

<sup>1</sup> For chain sling load capacities, please refer to the table on page 18 – 19.

## pewag MW Enlarged master link

### Universally connected.

A flattened section on the transition link opens up additional, universal connection possibilities. It is ideal for the simple, speedy assembly of I- and II-leg chains using Connex connecting elements, as a master link in welded systems and as an end link. Its inner dimensions are larger than those of the AW master link, making it suitable for larger crane hooks or special hooks.

The SAW master link without a flattened section is intended for transition links. The MW Enlarged Master Link must not be used for IV-leg chains, except when combined with BW transition links in VMW IV-leg assemblies.

Manufactured according to EN 1677-4 with mechanical values according to G10. With CE-marking and full operating manual.

See table below for the maximum crane hook size as specified by DIN 15401.



	Code	Load capacity 0 – 45° <sup>1</sup> [kg]	Can be used up to single hook acc. to DIN 15401	d [mm]	t [mm]	w [mm]	s [mm]	Weight [kg/pc.]	Master link for chain Ø I-leg MW I [mm]	II-leg MW II [mm]
	MW 10	1,400	no. 2.5	11	90	65	10	0.22	5	5
	MW 13	2,300	no. 4	14	120	70	10	0.44	6+7	6
	MW 16	3,200	no. 5	16	140	80	13	0.67	8	7
	MW 18	4,200	no. 6	19	160	95	14	1.09	10	8
	MW 22	6,700	no. 10	23	170	105	17	1.74	13	10
	MW 26	10,100	no. 10	27	190	110	20	2.65	16	13
	MW 32	16,000	no. 12	33	230	130	26	4.78	19	16
	MW 36	21,200	no. 20	38	275	150	29	7.48	22	19
	MW 56	40,000	no. 50	56	350	250	46	21.98	32	26
	SAW 32*	10,000	no. 50	33	540	250	26	9.25	-	-
	SAW 45*	22,500	no. 50	45	540	250	39	18.70	-	-
	SAW 60*	31,500	no. 100	60	800	320	55	48.00	-	-

<sup>1</sup> For chain sling load capacities, please refer to the table on page 18 – 19.

\* Discontinued article

## pewag BW Transition link

### Versatile by default.

This transition link is extremely versatile and can be used in a wide range of applications, for instance in welded systems, as a securing link welded into chain strands and as an end link. The flattened section opens up universal connection possibilities. The CE marking and BG approval ensure flawless quality. This transition link is manufactured according to EN 1677-4 with mechanical values according to G10 and is supplied with a full operating manual, offering users outstanding versatility at the highest level.

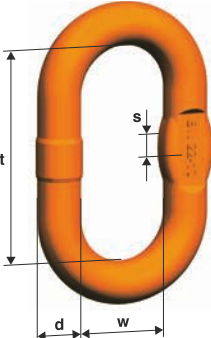

	Code	Load capacity 0 – 45° <sup>1</sup>	d	t	w	s	Weight	Transition link for chain Ø I- + II-leg BW I/II
BW Transition link		[kg]	[mm]	[mm]	[mm]	[mm]	[kg/pc.]	[mm]
	BW 7	1,000	7	36	16	7	0.03	5
	BW 8*	1,400	8	36	16	-	0.03	6
	BW 9	1,900	9	44	20	-	0.07	7
	BW 10	2,500	10	44	20	-	0.09	8
	BW 13	4,000	13	54	25	10	0.17	10
	BW 16	6,700	17	70	34	14	0.36	13
	BW 20	10,000	20	85	40	14	0.68	16
	BW 22	12,500	23	115	50	17	1.16	-
	BW 23*	14,000	23	115	45	17	1.15	19
	BW 26	16,200	27	140	65	20	1.92	-
	BW 27*	19,000	27	140	55	20	1.92	22
	BW 32	26,500	33	150	70	26	3.16	26
	BW 36	31,000	36	170	75	-	4.12	-
	BW 40	40,400	40	170	80	-	5.37	32
	BW 45	42,400	45	170	80	-	7.15	-
	BW 50	64,000	50	200	100	-	10.80	-

<sup>1</sup> For chain sling load capacities, please refer to the table on page 18 – 19.

\* Only in welded systems.



## pewag VW IV-leg master link assembly

### Universal connection possibilities.

This standard master link assembly is ideal for preparing III- and IV-leg chain slings in assembled or welded systems. It is manufactured according to EN 1677-4 with mechanical values for G10.

A flattened section on the transition links open up additional, universal connection possibilities. Includes CE marking, BG approval and full operating manual.

See table below for the maximum crane hook size as specified by DIN 15401.

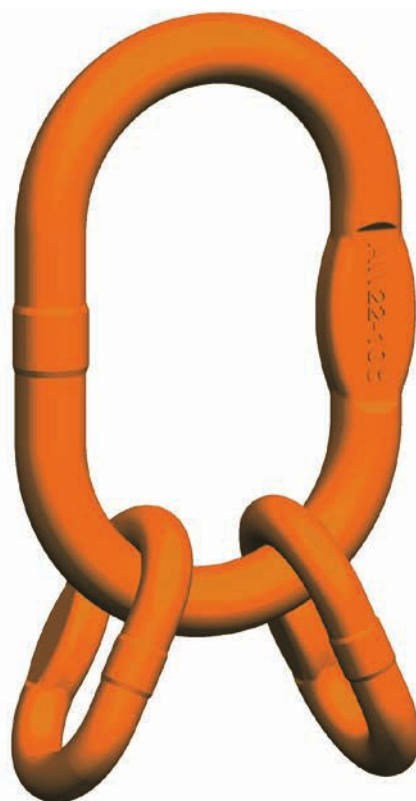

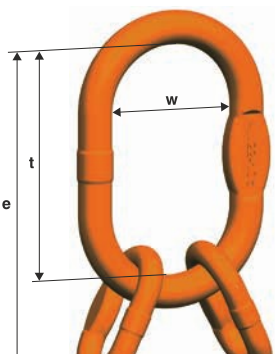
	Code*	Consists of	Load capacity 0 – 45° <sup>1</sup> [kg]	Can be used up to single hook according to DIN 15401	e [mm]	t [mm]	w [mm]	Weight [kg/pc.]
VW IV-leg master link assembly								
	VW 5	AW 13 + 2 BW 10	2,300	no. 2.5	154	110	60	0.52
	VW 6	AW 18 + 2 BW 13	4,200	no. 5	189	135	75	1.26
	VW 7/8	AW 22 + 2 BW 16	7,600	no. 6	230	160	90	2.32
	VW 10	AW 26 + 2 BW 20	9,600	no. 8	265	180	100	3.68
	VW 13	AW 32 + 2 BW 22	14,000	no. 10	315	200	110	6.46
	VW 16	AW 36 + 2 BW 26	21,200	no. 16	400	260	140	10.06
	VW 19/20	AW 50 + 2 BW 32	34,100	no. 32	500	350	190	22.87
	VW 22	AW 50 + 2 BW 36	40,000	no. 32	520	350	190	24.79
	VW 26	AW 56 + 2 BW 45	56,000	no. 32	570	400	200	41.31
	VW 32	AW 72 + 2 BW 50	85,000	no. 50	660	460	250	66.60

<sup>1</sup> For chain sling load capacities, please refer to the table on page 18 – 19.

\* Please note that this allocation does not apply to suspension systems with a load distributor.

# pewag VMW Enlarged IV-leg master link assembly

## True greatness for your load.

This master link assembly for III- and IV-leg chain slings in assembled or welded systems complies with EN 1677-4 and the mechanical values for G10.

A flattened section on the transition links opens up additional, universal connection possibilities. Thanks to the use of MW links, this master link assembly has larger inside dimensions than the VW IV-leg chain sling and can thus also be used for the next size up crane hooks.

See table below for the maximum crane hook size as specified by DIN 15401. This powerful package comes with CE marking and a full operating manual.

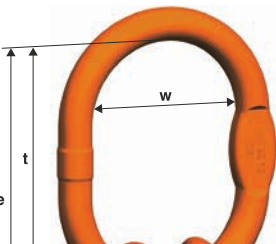

VMW Enlarged IV-leg master link assembly	Code	Consists of	Load capacity 0 – 45° <sup>1</sup>	Can be used up to single hook acc. to DIN 15401	e	t	w	Weight
			[kg]		[mm]	[mm]	[mm]	[kg/pc.]
	VMW 6	MW 18 + 2 BW 13	4,200	no. 6	214	160	95	1.43
	VMW 7/8	MW 22 + 2 BW 16	6,600	no. 10	240	170	105	2.46
	VMW 10	MW 26 + 2 BW 20	10,100	no. 10	275	190	110	4.01
	VMW 13	MW 32 + 2 BW 22	15,700	no. 12	345	230	130	6.90
	VMW 16	MW 36 + 2 BW 26	21,200	no. 20	415	275	150	11.12
	VMW 19/20	MW 56 + 2 BW 32	34,100	no. 50	500	350	250	28.08
	VMW 22	MW 56 + 2 BW 36	40,000	no. 50	520	350	250	30.62

<sup>1</sup> For chain sling load capacities, please refer to the table on page 18 – 19.

\* Please note that this allocation does not apply to suspension systems with a load distributor.

# pewag VAW Special IV-leg master link assembly

## An XL range of applications.

Thanks to the flattened section on the transition links, this IV-leg master link assembly can be used for III- and IV-leg chain slings in the assembled or welded system and is even more versatile due to universal connection possibilities.

If safety is your strongest argument, you can't do better than choose this IV-leg master link assembly with extra-large transition links for assembling your chain slings. For use in rope slings, please consider that load capacity is indicated with safety factor 4!

See table below for the maximum crane hook size as specified by DIN 15401.

The chain sling complies with EN 1677-4 and the mechanical values for G10. Includes CE-marking and full operating manual.

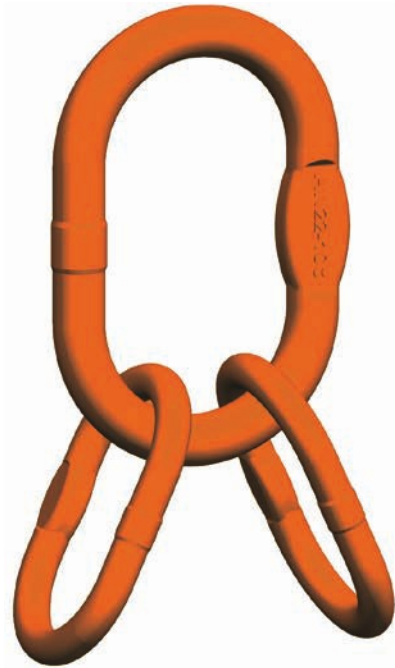

	Code*	Consists of	Load capacity 0 – 45° <sup>1</sup> [kg]	Can be used up to single hook acc. to DIN 15401	e [mm]	t [mm]	w [mm]	Weight [kg/pc.]
<p>VAW Special IV-leg master link assembly</p>	VAW 6/7	AW 18 + 2 AW 14	5,000	no. 5	245	135	75	1.72
	VAW 8	AW 22 + 2 AW 16	6,300	no. 6	270	160	90	2.66
	VAW 10	AW 26 + 2 AW 18	9,500	no. 8	315	180	100	4.30
	VAW 13	AW 32 + 2 AW 26	16,100	no. 10	380	200	110	9.06
	VAW 16	AW 36 + 2 AW 32	25,100	no. 16	460	260	140	14.50
	VAW 19/20	AW 50 + 2 MW 36	41,100	no. 32	625	350	190	31.51
	VAW 22	AW 50 + 2 AW 45	47,400	no. 32	690	350	190	42.19
	VAW 26	AW 56 + 2 AW 50	58,000	no. 32	750	400	200	60.11
	VAW 32	AW 72 + 2 AW 56	85,000	no. 50	860	460	250	99.02

<sup>1</sup> For chain sling load capacities, please refer to the table on page 18 – 19.

\* Please note that this allocation does not apply to suspension systems with a load distributor.

# pewag VLW 1 Oversize master link assembly

## Compelling simplicity.

This master link assembly for I-leg chain slings in assembled or welded systems complies with EN 1677-4 and the mechanical values for G10. Extra-large rings make this master link assembly the perfect partner for crane hooks according to DIN 15401 up to no. 25. A flattened section on the transition links open up additional, universal connection possibilities.

This true all-rounder comes with a full operating manual. CE marking and BG approval ensure quality of the highest order.

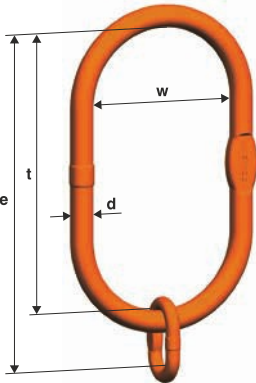

VLW 1 Oversize master link assembly	Code	Consists of	Load capacity [kg]	Can be used up to single hook acc. to DIN 15401	e [mm]	d [mm]	t [mm]	w [mm]	Weight [kg/pc.]
	VLW 1-6/7/8	LW 22 + BW 13	2,500	no. 25	394	22	340	180	3.40
	VLW 1-10	LW 27 + BW 16	4,000	no. 25	410	27	340	180	4.80
	VLW 1-13	LW 27	6,700	no. 25	340	27	340	180	4.40
	VLW 1-16	LW 32	10,000	no. 25	340	33	340	180	6.70
	VLW 1-19/22	LW 40	19,000	no. 25	340	40	340	180	10.00

**Example:** VLW 1-6/7/8 can be used for I-leg slings with 6 mm, 7 mm and 8 mm chains.

## pewag VLW 2/4 Oversize master link assembly

### Effortless adaptability.

This master link assembly is designed for the effortless creation of II- and IV-leg chain slings in the assembled or welded system. The flattened section on the transition links opens up additional, universal connection possibilities. Extra-large rings make this master link assembly the perfect partner for crane hooks according to DIN 15401 up to no. 25. This master link assembly also comes with CE marking and BG approval and was manufactured according to EN 1677-4, with the mechanical values of the G10 programme.

A full operating manual provides detailed information on all potential areas of use.



Code	Consists of	Load capacity 0 – 45° [kg]	Can be used up to single hook acc. to DIN 15401	e [mm]	d [mm]	t [mm]	w [mm]	Weight [kg/pc.]
VLW 2-6/7/8/4-6	LW 22 + 2 BW 13	3,550	no. 25	394	22	340	180	3.50
VLW 2-10/4-7/8	LW 27 + 2 BW 16	5,600	no. 25	410	27	340	180	5.10
VLW 2-13/4-10	LW 32 + 2 BW 20	9,500	no. 25	425	33	340	180	8.00
VLW 2-16/4-13	LW 40 + 2 BW 22	14,000	no. 25	455	40	340	180	12.30
VLW 2-19/4-16	LW 40 + 2 BW 26	21,200	no. 25	480	40	340	180	13.80

VLW 2/4 Oversize master link assembly

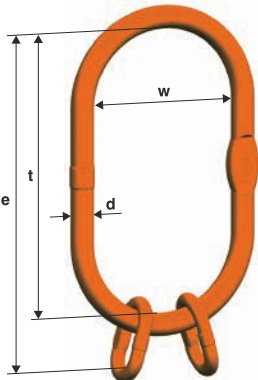

**Example of multi-leg chain sling:** VLW 2-10/4-7/8 can be used for 10 mm II-leg slings and for 7+8 mm IV-leg slings.

# pewag VSW 2/4 Oversize master link assembly

## Versatile and effortless adaptability.

This master link assembly is designed for the effortless creation of II- and IV-leg chain slings in the assembled or welded system. The flattened section on the transition links opens up additional, universal connection possibilities. Extra-large rings make this master link assembly the perfect partner for crane hooks according to DIN 15401 up to no. 40. This master link assembly also comes with CE marking and was manufactured according to EN 1677-4, with the mechanical values of the G10 programme.

A full operating manual provides detailed information on all potential areas of use.

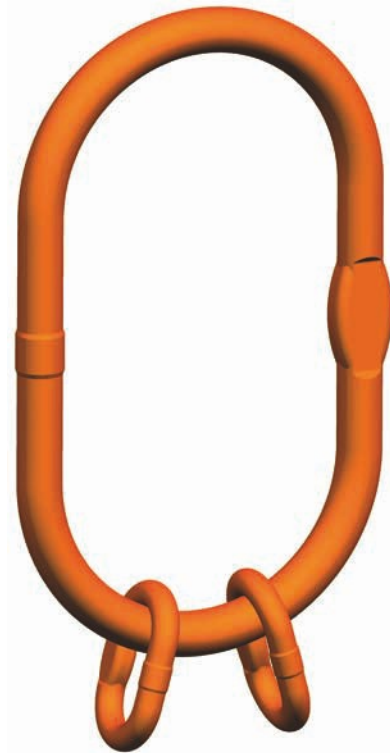

Code	Consists of	Load capacity 0 – 45° <sup>1</sup> [kg]	Can be used up to single hook acc. to DIN 15401	e [mm]	d [mm]	t [mm]	w [mm]	s [mm]	Weight [kg/pc.]
<b>VSW 2/4 Oversize master link assembly</b>									
VSW 2-10 / 4-8	SW 30 + 2 BW 20	5,600	Nr. 40	515	30	430	220	24	8.16
VSW 2-13 / 4-10	SW 33 + 2 BW 20	9,500	Nr. 40	515	33	430	220	26	9.66
VSW 2-16 / 4-13	SW 36 + 2 BW 22	14,000	Nr. 40	545	36	430	220	29	12.32
VSW 2-19/20 / 4-16	SW 45 + 2 BW 26	21,200	Nr. 40	570	45	430	220	-	19.54

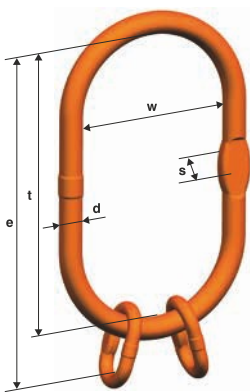

**Example of multi-leg chain sling:** VSW 2-10/4-8 can be used for 10 mm II-leg slings and for 8 mm IV-leg slings.

## pewag VSAW 1 Master link assembly

### A simple case of excellence.

Ideal for the quick and safe mounting of transition assemblies. These master links make it possible to create extremely short assemblies, facilitating the switch from a large to a small crane hook - useful in many lifting and transport processes!

This standard master link assembly is ideal for preparing I-leg chain slings in assembled or welded systems and have a load capacity of up to 40,000 kg. Extra-large internal ring dimensions that are suitable for single hooks according to DIN 15401 no. 50/100 are yet another outstanding feature of these products.

A flattened ring section opens up universal adaptation possibilities that are also outlined in the full operating manual. The assemblies are manufactured according to EN 1677-4 with the mechanical values of G10 and come with a CE marking for certified quality.

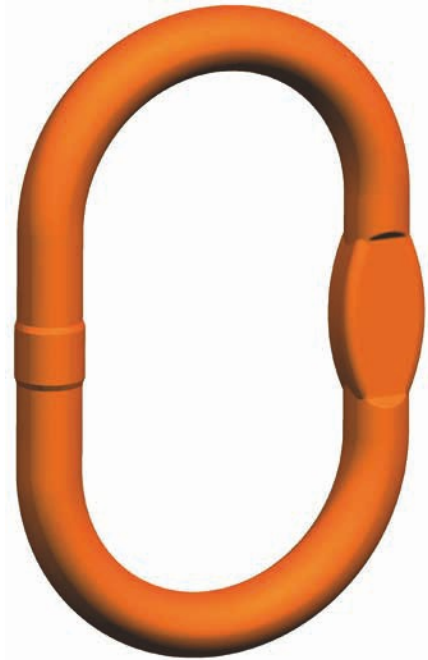

	Code	Consists of	Load capacity* [kg]	Can be used up to single hook acc. to DIN 15401	d [mm]	t [mm]	w [mm]	Weight [kg/pc.]
	VSAW 1-10/13	SAW 32+BW 20	10,000	no. 50	33	500	250	10.00
	VSAW 1-16	SAW 32	10,000	no. 50	33	500	250	9.33
	VSAW 1-19	SAW 40	16,000	no. 50	40	460	250	13.13
	VSAW 1-22	SAW 45	22,400	no. 50	45	500	250	17.81
	VSAW 1-26	SAW 50	33,600	no. 50	50	460	250	21.00
	VSAW 1-32	SAW 56	40,000	no. 50	56	460	250	26.10
	VSAW 1-32 320	SAW 60	40,000	no. 100	60	800	320	48.00

\* For chain sling load capacities, please refer to the table on page 18 – 19.

# pewag VSAW 2 Master link assembly

## Two legs in G10.

The VSAW 2 assembly comes with the same benefits as the VSAW 1 assembly and can also be used to create transition assemblies. This system is ideal for simplifying lifting and transport processes as it enables the creation of very short transition assemblies, thereby facilitating the switch from a large to a small crane hook.

With a load capacity of up to 40,000 kg, these master links may be used to create II-, III- and IV-leg chain slings in the assembled or welded system. The flattened section on the rings make them universally adaptable and the extra-large interior dimensions of the rings make them easy to use with single hooks according to DIN 15401 no. 50/100.

The assemblies are manufactured according to EN 1677-4 with the mechanical values of G10 and come with a CE marking for certified quality. A full operating manual is provided.

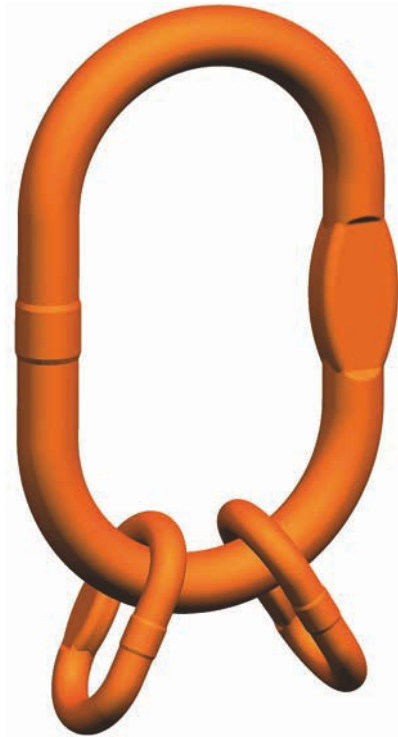

	Code	Consists of	Load capacity 0 – 45°* [kg]	Can be used up to single hook acc. to DIN 15401	e [mm]	d [mm]	t [mm]	w [mm]	Weight [kg/pc.]
	VSAW 2-10/13 / 4-10	SAW 32 + 2 BW 20	9,500	no. 50	585	33	500	250	10.69
	VSAW 2-16 / 4-13	SAW 40 + 2 BW 22	14,000	no. 50	575	40	460	250	15.45
	VSAW 2-19/20 / 4-16	SAW 45 + 2 BW 26	21,200	no. 50	640	45	500	250	21.65
	VSAW 2-22 / 4-19/20	SAW 50 + 2 BW 32	30,000	no. 50	610	50	460	250	27.32
	VSAW 2-26 / 4-22	SAW 56 + 2 BW 32	40,000	no. 50	610	56	460	250	34.30
	VSAW 2-26 / 4-22 / 320	SAW 60 + 2 BW 32	40,000	no. 100	950	60	800	320	54.32

\* For chain sling load capacities, please refer to the table on page 18 – 19.



## pewag KAGW 1 Clevis master set

### Mission accomplished.

This high-performance master set consists of an AW master ring and a welded-in KRW captive coupling for creating I-leg chain slings in the assembled system. The chain is mounted directly into the coupling, thereby eliminating the need for an additional connecting link. This product is easily assembled and disassembled by a competent person – no special tools required!

It is manufactured according to EN 818-4 with the mechanical values of G10, comes with a CE mark and BG-approval and with a comprehensive operating manual. The coupling pin and the lock pin are available as a KBSW spare parts set.



KAGW 1 Clevis master set	Code	Load capacity	For	Can be used up	d	t	w	e	Weight
		[kg]	chain Ø	to single hook acc. to DIN 15401	[mm]	[mm]	[mm]	[mm]	[kg/pc.]
	KAGW 1-6 *	1,400	6	no. 2.5	13	110	60	141	0.42
	KAGW 1-7	1,900	7	no. 2.5	13	110	60	153	0.54
	KAGW 1-8	2,500	8	no. 2.5	16	110	60	153	0.73
	KAGW 1-10	4,000	10	no. 5	19	135	75	186	1.28
	KAGW 1-13	6,700	13	no. 6	23	160	90	223	2.30
	KAGW 1-16	10,000	16	no. 8	27	180	100	254	3.67
	KAGW 1-19/20	14,000	19	no. 10	33	200	110	294	6.52
	KAGW 1-22	19,000	22	no. 16	36	260	140	362	9.43

\* May also be used with a 5 mm chain if load capacity is adjusted accordingly.

**Example:** KAGW 1-10 may be used for I-leg chain slings with a 10 mm chain.

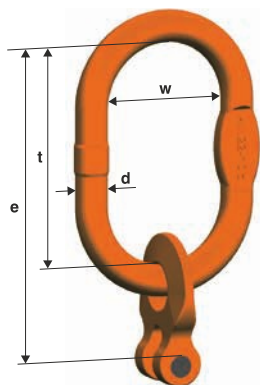

# pewag KAGW 2 Clevis master set

## Coupled for life.

The chain is mounted directly into the coupling, thereby eliminating the need for an additional connecting link. This master set, consisting of an AW master ring and two welded-in KRW captive couplings, is easy to assemble and disassemble for the creation of II-leg chain slings in the assembled system. The set is manufactured according to EN 818-4 with mechanical values for G10.

This clevis master set comes with CE marking and BG approval. Assembly may be performed by a competent person without special tools being required.

The coupling pin and the lock pin are available as a KBSW spare parts set. A full operating manual is provided.



KAGW 2 Clevis master set	Code	Load capacity 0° – 45°/45° – 60° [kg]	For chain Ø	Can be used up to single hook acc. to DIN 15401	d [mm]	t [mm]	w [mm]	e [mm]	Weight [kg/pc.]
	KAGW 2-6 *	2,000 / 1,400	6	no. 2.5	13	110	60	141	0.50
	KAGW 2-7	2,650 / 1,900	7	no. 2.5	16	110	60	153	0.93
	KAGW 2-8	3,550 / 2,500	8	no. 5	19	135	75	178	1.26
	KAGW 2-10	5,600 / 4,000	10	no. 6	23	160	90	211	2.32
	KAGW 2-13	9,500 / 6,700	13	no. 8	27	180	100	243	3.86
	KAGW 2-16	14,000 / 10,000	16	no. 10	33	200	110	274	6.56
	KAGW 2-19/20	20,000 / 14,000	19	no. 16	36	260	140	354	10.98
	KAGW 2-22	26,500 / 19,000	22	no. 25	45	340	180	442	19.24

\* May also be used with a 5 mm chain if load capacity is adjusted accordingly.

**Example:** KAGW 2-10 may be used for II-leg chain slings with a 10 mm chain.

## pewag KAGW 4 Clevis master set

### Extra legroom.

This high-grade KAGW master set consists of a VW IV-leg assembly and four welded-in KRW captive couplings for the creation of IV-leg chain slings in the assembled system.

The chain is mounted directly into the coupling, thereby eliminating the need for an additional connecting link. A competent person will assemble and disassemble the system easily and quickly, without the need for special tools.

The clevis master set is manufactured according to EN 818-4 with mechanical values for G10. A full operating manual, CE-marking and BG-approval vouchsafe for the safety of this system. The coupling pin and the lock pin are available as a KBSW spare parts set.

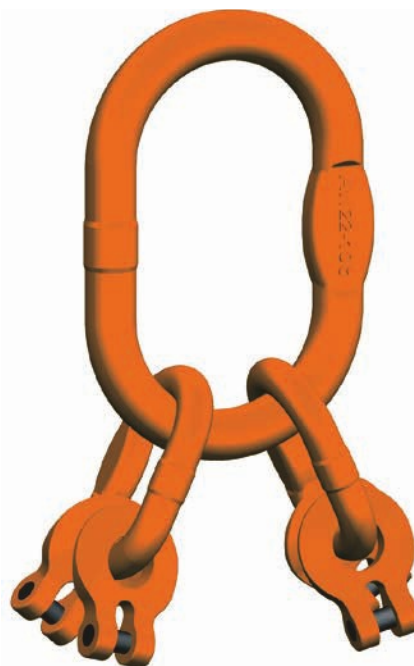

KAGW 4 Clevis master set	Code	Load capacity 0° – 45°/45° – 60° [kg]	For chain Ø	Can be used up to single hook acc. to DIN 15401	d [mm]	t [mm]	w [mm]	e [mm]	Weight [kg/pc.]
	KAGW 4-6 *	3,000 / 2,120	6	no. 5	19	135	75	220	1.52
	KAGW 4-7	4,000 / 2,800	7	no. 6	23	160	90	273	3.12
	KAGW 4-8	5,300 / 3,750	8	no. 6	23	160	90	273	3.12
	KAGW 4-10	8,000 / 6,000	10	no. 8	27	180	100	316	5.12
	KAGW 4-13	14,000 / 10,000	13	no. 10	33	200	110	378	9.26
	KAGW 4-16	21,200 / 15,000	16	no. 16	36	260	140	474	14.90
	KAGW 4-19/20	30,000 / 21,200	19	no. 32	50	350	190	594	32.39
	KAGW 4-22	40,000 / 28,000	22	no. 32	50	350	190	622	37.63

\* May also be used with a 5 mm chain if load capacity is adjusted accordingly.

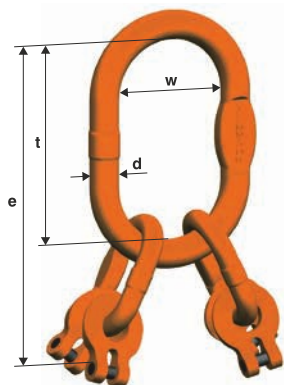

**Example:** KAGW 4-10 may be used for IV-leg chain slings with a 10 mm chain.

## pewag KMGW 1 Enlarged clevis master set

### Your crane hook in good hands.

The MW master ring and the welded-in KRW captive coupling are the perfect pair for creating I-leg chain slings in the assembled system. The chain is mounted directly in the coupling, thereby eliminating the need for an additional connecting link.

Disassembly is also simple and can be completed without special tools. However, make sure that it is performed by a competent person. An extra plus result from the enlarged internal dimensions of the master ring, which make it suitable for the next size up crane hook.

The set is manufactured according to EN 818-4 with mechanical values for G10 and comes with CE-marking and a full operating manual. The coupling pin and the lock pin are available as a KBSU spare parts set.



KMGW 1 Enlarged clevis master set	Code	Load capacity [kg]	For chain Ø	Can be used up to single hook acc. to DIN 15401	d [mm]	t [mm]	w [mm]	e [mm]	Weight [kg/pc.]
	KMGW 1-6 *	1,400	6	no. 4	14	120	70	151	0.52
	KMGW 1-8	2,500	8	no. 5	16	140	80	183	0.87
	KMGW 1-10	4,000	10	no. 6	19	160	95	211	1.45
	KMGW 1-13	6,700	13	no. 10	23	170	105	233	2.44
	KMGW 1-16	10,000	16	no. 10	27	190	110	264	3.86

\* May also be used with a 5 mm chain if load capacity is adjusted accordingly.

**Example:** KMGW 1-10 may be used for I-leg chain slings with a 10 mm chain.

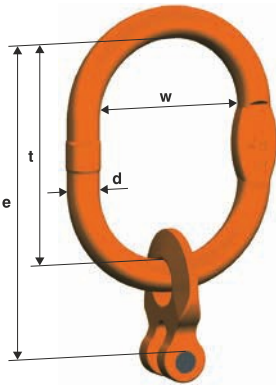

## pewag KMGW 2 Enlarged clevis master set

### Assurance, double sure.

The chain is mounted directly into the captive coupling, eliminating the need for an additional connecting link. This makes the master set with a MW master ring and two welded-in KRW captive couplings even better suited for creating II-leg chain slings in the assembled system. Product features include easy assembly and disassembly by a competent person without the need for special tools – benefits that speak for themselves! Extra-large internal dimensions of the master ring also make this system suitable for the next size up crane hook.

The set comes with a full operating manual. A CE marking is standard. The extra-large clevis master set is manufactured according to EN 818-4 with mechanical values for G10.

Coupling bolt and lock pin are available as a KBSW spare parts set – yet another weighty benefit of this set!

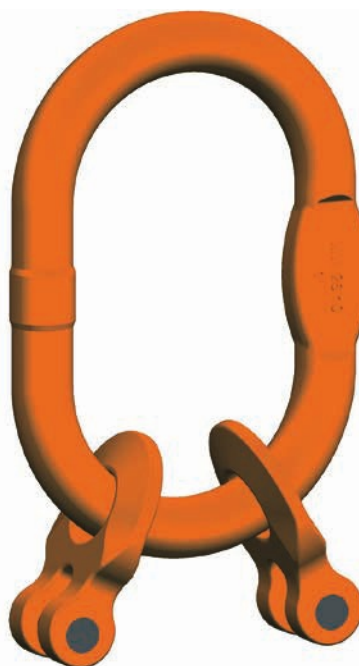

KMGW 2 Enlarged clevis master set	Code	Load capacity 0° – 45°/45° – 60° [kg]	For chain Ø	Can be used up to single hook acc. to DIN 15401	d [mm]	t [mm]	w [mm]	e [mm]	Weight [kg/pc.]
	KMGW 2-6 *	2,000 / 1,400	6	no. 4	14	120	70	151	0.60
	KMGW 2-8	3,550 / 2,500	8	no. 6	19	160	95	203	1.49
	KMGW 2-10	5,600 / 4,000	10	no. 10	23	170	105	221	2.46
	KMGW 2-13	9,500 / 6,700	13	no. 10	27	190	110	253	4.05
	KMGW 2-16	14,000 / 10,000	16	no. 12	33	230	130	304	7.20

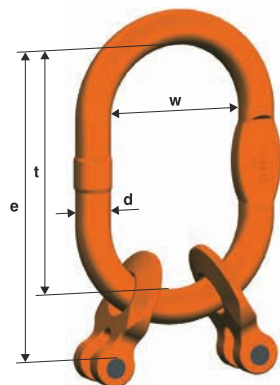

\* May also be used with a 5 mm chain if load capacity is adjusted accordingly.

**Example:** KMGW 2-10 may be used for II-leg chain slings with a 10 mm chain.

# pewag KMGW 4 Enlarged clevis master set

## Four-fold strength that withstands anything.

This clevis master set is manufactured according to EN 818-4 with mechanical values of G10 and consists of the VMW enlarged IV-leg assembly and four welded-in KRW captive couplings. This master set is ideal for the creation of IV-leg chain slings in the assembled system. The chain may simply be mounted directly into the captive coupling by a competent person, without the need for special tools. Disassembly is also easy and fast.

Enlarged internal dimensions of the master ring make this product suitable for the next size up crane hook – one of the outstanding pewag features! The coupling pin and the lock pin are available as KBSW spare parts sets.

This four-fold package comes with CE-marking and a full operating manual.

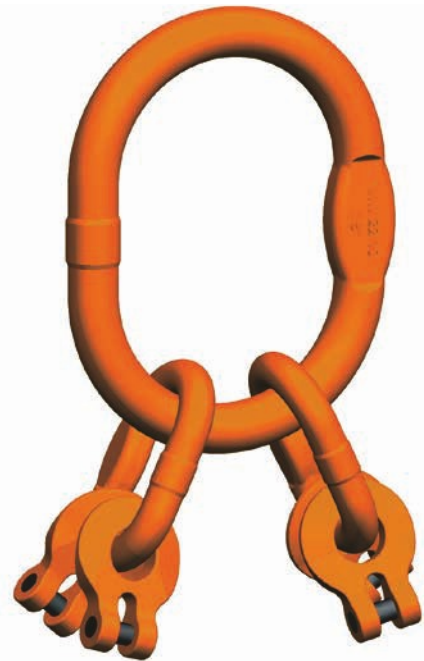

KMGW 4 Enlarged clevis master set	Code	Load capacity 0° – 45°/45° – 60° [kg]	For chain Ø	Can be used up to single hook acc. to DIN 15401	d [mm]	t [mm]	w [mm]	e [mm]	Weight [kg/pc.]
	KMGW 4-6 *	3,000 / 2,120	6	no. 6	19	160	95	245	1.75
	KMGW 4-8	5,300 / 3,750	8	no. 10	23	170	105	283	3.26
	KMGW 4-10	8,000 / 6,000	10	no. 10	27	190	110	326	5.45
	KMGW 4-13	14,000 / 10,000	13	no. 12	33	230	130	408	9.90
	KMGW 4-16	21,200 / 15,000	16	no. 20	38	275	150	489	16.00

\* May also be used with a 5 mm chain if load capacity is adjusted accordingly.

**Example:** KMGW 4-10 may be used for IV-leg chain slings with a 10 mm chain.

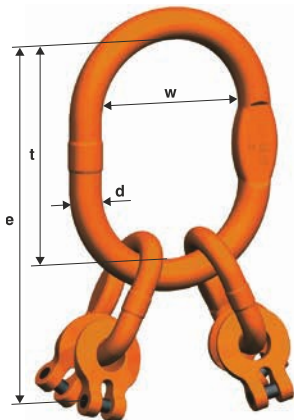

## pewag VXKW 1 Clevis master set

### A leg to stand on.

Trust is good, control is better - and this assembly delivers on both accounts. This safety product complies with EN 818-4 and has the mechanical values of G10. The chain is mounted directly into the coupling unit of the shortening element, thereby eliminating the need for an additional connecting link. The hook functions both as a connecting link and a shortening element, making for simple assembly and disassembly by a competent person, without the need for special tools.

This master set consists of a AW master ring and a welded-in XKW shortening hook for the creation of IV-leg chain slings in the assembled system.

CE marking and BG approval are guaranteed and a full operating manual is included. The coupling pin and the lock pin are available as a KBSW spare parts set.



VXKW 1 Clevis master set	Code	Load capacity	For chain	Can be used up	d	t	w	e	Weight
		[kg]	Ø	to single hook acc. to DIN 15401	[mm]	[mm]	[mm]	[mm]	[kg/pc.]
	VXKW 1-5	1,000	5	no. 1.6	10	80	50	164	0.44
	VXKW 1-6	1,400	6	no. 2.5	13	110	60	194	0.64
	VXKW 1-7	1,900	7	no. 2.5	13	110	60	232	0.96
	VXKW 1-8	2,500	8	no. 2.5	16	110	60	232	1.16
	VXKW 1-10	4,000	10	no. 5	19	135	75	294	2.11
	VXKW 1-13	6,700	13	no. 6	23	160	90	363	4.30
	VXKW 1-16	10,000	16	no. 8	27	180	100	413	7.26

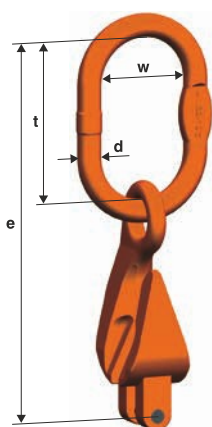

**Example:** VXKW 1-10 may be used for I-leg chain slings with a 10 mm chain.

## pewag VXKW 2 Clevis master set

### A cut above the rest.

This clevis master set also eliminates the need for an additional connecting element as the chain may be attached directly to the captive coupling of the shortening element. The set consists of an AW master ring and two welded-in XKW shortening hooks, facilitating the speedy assembly and disassembly of II-leg chain slings in the assembled system by a competent person, without the need for special tools. The hook functions both as a connecting and a shortening element.

The clevis master set is manufactured according to EN 818-4 with mechanical values for G10. This all-round package comes with CE-marking, BG approval and a full operating manual.

The coupling pin and the lock pin are available as a KBSW spare parts set.

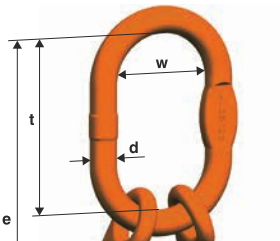

VXKW 2 Clevis master set	Code	Load capacity 0° – 45° / 45° – 60° [kg]	For chain Ø	Can be used up to single hook acc. to DIN 15401	d [mm]	t [mm]	w [mm]	e [mm]	Weight [kg/pc.]
	VXKW 2-5	1,400 / 1,000	5	no. 1.6	10	80	50	164	0.74
	VXKW 2-6	2,000 / 1,400	6	no. 2.5	13	110	60	194	0.94
	VXKW 2-7	2,650 / 1,900	7	no. 2.5	16	110	60	232	1.77
	VXKW 2-8	3,550 / 2,500	8	no. 5	19	135	75	257	2.12
	VXKW 2-10	5,600 / 4,000	10	no. 6	23	160	90	319	4.10
	VXKW 2-13	9,500 / 6,700	13	no. 8	27	180	100	383	7.86
	VXKW 2-16	14,000 / 10,000	16	no. 10	33	200	110	433	13.74

**Example:** VXKW 2-10 may be used for II-leg chain slings with a 10 mm chain.



# pewag VXKW 4 Clevis master set

## Multi-tasking.

Assembly and disassembly of the system by a competent person is easy and quick, without the need for special tools. The chain is mounted directly into the captive coupling of the shortening element, thereby eliminating the need for an additional connecting link. Once mounted, this IB-leg master set with four welded-in XKW shortening hooks for the assembly of IV-leg chain slings in the assembled system will not be budged! The hook functions both as a connecting link and a shortening element – multi-functional in the true sense of the word!

The set is manufactured according to EN 818-4 with the mechanical values of G10 and come with a CE marking for certified quality and BG approval.

A full operating manual and the KBSW spare parts set consisting of coupling pin and lock pin are also included in the delivery.

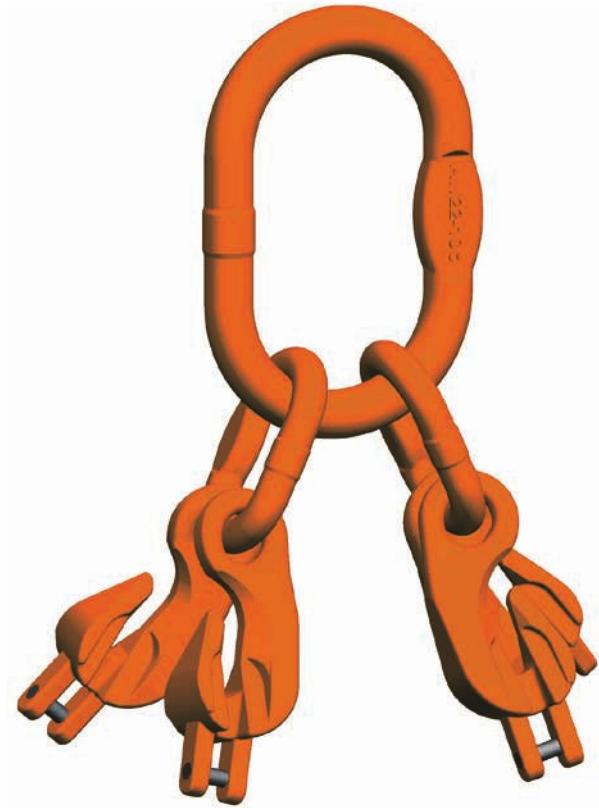

	Code	Load capacity 0° – 45° / 45° – 60° [kg]	For chain Ø	Can be used up to single hook acc. to DIN 15401	d [mm]	t [mm]	w [mm]	e [mm]	Weight [kg/pc.]
	VXKW 4-5	2,000 / 1,500	5	no. 2.5	13	110	60	238	1.72
	VXKW 4-6	3,000 / 2,120	6	no. 5	19	135	75	273	2.40
	VXKW 4-7	4,000 / 2,800	7	no. 6	23	160	90	352	4.84
	VXKW 4-8	5,300 / 3,750	8	no. 6	23	160	90	352	4.84
	VXKW 4-10	8,000 / 6,000	10	no. 8	27	180	100	424	8.82
	VXKW 4-13	14,000 / 10,000	13	no. 10	33	200	110	518	17.26
	VXKW 4-16	21,200 / 15,000	16	no. 16	36	260	140	633	29.26

**Example:** VXKW 4-10 may be used for IV-leg chain slings with a 10 mm chain.

## pewag VMXKW 1 Clevis master set

### Always reliable.

With this assembly, there is no compromise when it comes to security. This safety product complies with EN 818-4 and has the mechanical values of G10. The chain is mounted directly into the coupling unit of the shortening element, thereby eliminating the need for an additional connecting link. The hook functions both as a connecting link and a shortening element, making for simple assembly and disassembly by a competent person, without the need for special tools.

This master set consists of a MW master ring and a welded-in XKW shortening hook for the creation of IV-leg chain slings in the assembled system.

CE marking is guaranteed and a full operating manual is included. The coupling pin and the lock pin are available as a KBSW spare parts set.



VMXKW 1 Clevis master set	Code	Load capacity [kg]	For chain Ø	Can be used up to single hook acc. to DIN 15401	d [mm]	t [mm]	w [mm]	e [mm]	Weight [kg/pc.]
	VMXKW 1-6	1,400	6	4	14	120	70	204	0.74
	VMXKW 1-7	1,900	7	4	14	120	70	242	1.06
	VMXKW 1-8	2,500	8	5	16	140	80	262	1.30
	VMXKW 1-10	4,000	10	6	19	160	95	319	2.40
	VMXKW 1-13	6,700	13	10	23	170	105	373	4.39
	VMXKW 1-16	10,000	16	10	27	190	110	424	7.45

**Example:** VMXKW 1-10 may be used for I-leg chain slings with a 10 mm chain.

## pewag VMXKW 2 Clevis master set

### These two can handle this.

The fact that the hook functions both as a connecting and a shortening element, there is no additional connecting element needed. The chain may attached directly to the captive coupling of the shortening element.

The set consists of a MW master ring and two welded-in XKW shortening hooks, facilitating the speedy assembly and disassembly of II-leg chain slings in the assembled system by a competent person, without the need for special tools.

The clevis master set is manufactured according to EN 818-4 with mechanical values for G10. This all-round package comes with CE-marking and a full operating manual.

The coupling pin and the lock pin are available as a KBSW spare parts set.

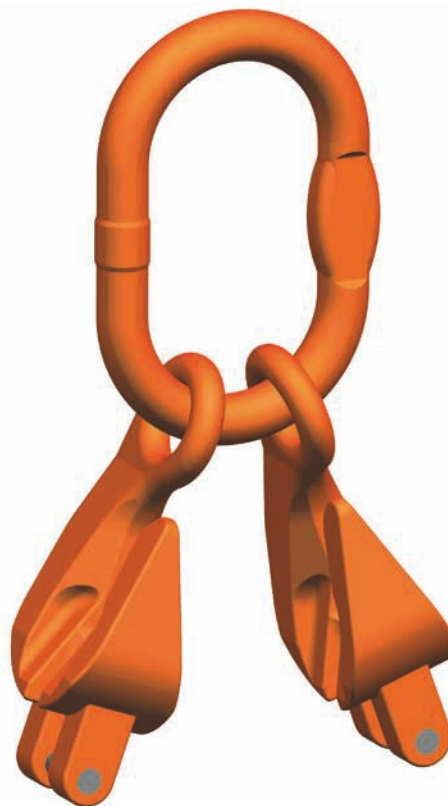

VMXKW 2 Clevis master set	Code	Load capacity 0° – 45° / 45° – 60° [kg]	For chain Ø	Can be used up to single hook acc. to DIN 15401	d [mm]	t [mm]	w [mm]	e [mm]	Weight [kg/pc.]
	VMXKW 2-6	2,000 / 1,400	6	4	14	120	70	204	1.04
	VMXKW 2-7	2,650 / 1,900	7	5	16	140	80	262	1.91
	VMXKW 2-8	3,550 / 2,500	8	6	19	160	95	282	2.35
	VMXKW 2-10	5,600 / 4,000	10	10	23	170	105	329	4.19
	VMXKW 2-13	9,500 / 6,700	13	10	27	190	110	393	8.05
	VMXKW 2-16	14,000 / 10,000	16	12	33	230	130	464	14.38

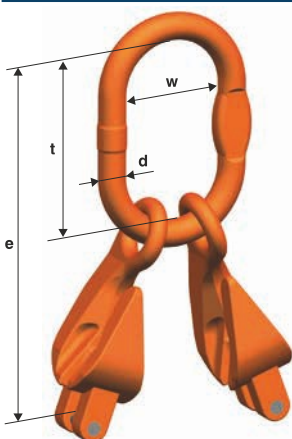

**Example:** VMXKW 2-10 may be used for II-leg chain slings with a 10 mm chain.

## pewag VMXKW 4 Clevis master set

### When more is a must.

Just as VXKW 1 and 2, the chain may be attached directly to the captive coupling of the shortening element. This has the advantage, that there is no additional connecting element needed, because the hook functions both as a connecting and a shortening element. The assembly and disassembly is done easily, quickly and without special tool by a competent person. Once mounted, this IV-leg master set with four welded-in XKW shortening hooks for the assembly of IV-leg chain slings in the assembled system will not be budged!

The set is manufactured according to EN 818-4 with the mechanical values of G10 and come with a CE marking for certified quality.

A full operating manual and the KBSW spare parts set consisting of coupling pin and lock pin are also included in the delivery.

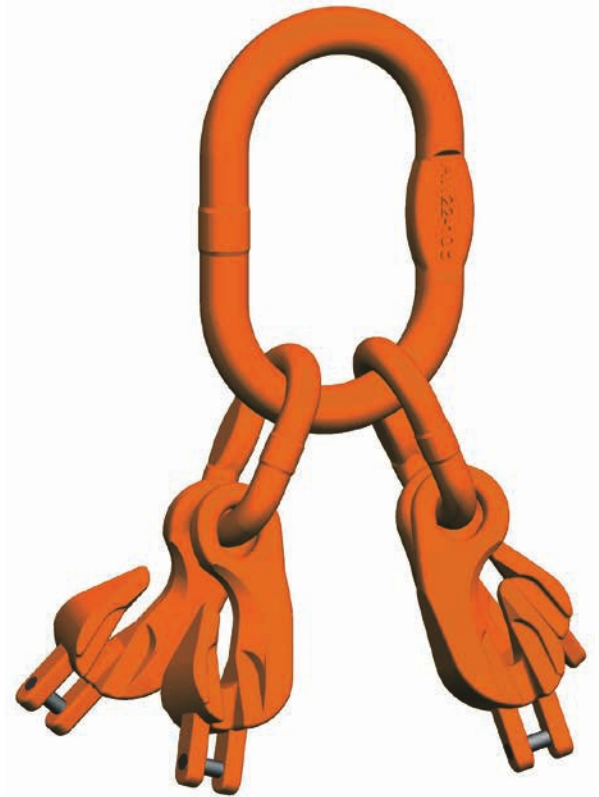

VMXKW 4 Clevis master set	Code	Load capacity 0° – 45° / 45° – 60° [kg]	For chain Ø	Can be used up to single hook acc. to DIN 15401	d [mm]	t [mm]	w [mm]	e [mm]	Weight [kg/pc.]
	VMXKW 4-6	3,000 / 2,120	6	6	19	160	95	298	2.40
	VMXKW 4-7	4,000 / 2,800	7	10	23	170	105	362	4.84
	VMXKW 4-8	5,300 / 3,750	8	10	23	170	105	362	4.84
	VMXKW 4-10	8,000 / 6,000	10	10	27	190	110	434	8.82
	VMXKW 4-13	14,000 / 10,000	13	12	33	230	130	548	17.26
	VMXKW 4-16	21,200 / 15,000	16	20	38	275	150	649	29.26

**Example:** VMXKW 4-10 may be used for IV-leg chain slings with a 10 mm chain.

## pewag L XKW 1 Oversize clevis master set

### Well connected.

This oversize clevis master set is frequently used on mobile cranes. It consists of an LW master ring and a welded-in XKW shortening hook for the creation of I-leg chain slings in the assembled system. The chain is mounted directly into the captive coupling of the shortening element, thereby eliminating the need for an additional connecting link. Assembly and disassembly of the system by a competent person is easy and quick, without the need for special tools. The hook functions both as a connecting link and a shortening element and the master link is suitable for crane hooks no. 25 according to DIN 15401.

The set is manufactured according to EN 818-4 with the mechanical values of G10, comes with CE marking and BG approval as well as a full operating manual.

The coupling pin and the lock pin are available as a KBSW spare parts set.

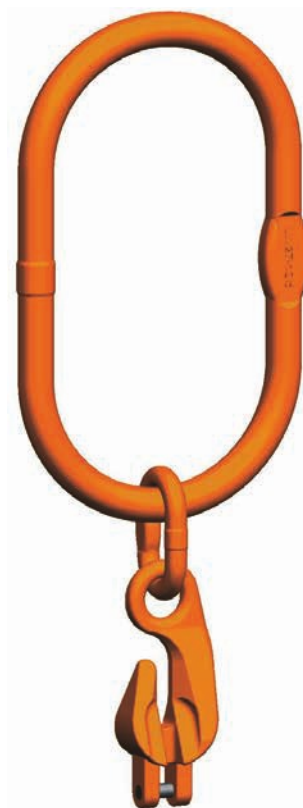

LXKW 1 Oversize clevis master set	Code	Load capacity	Can be used up to single hook acc. to DIN 15401	d	t	w	e	Weight
		[kg]		[mm]	[mm]	[mm]	[mm]	[kg/pc.]
	LXKW 1-6 *	1,400	no. 25	23	340	180	478	3.70
	LXKW 1-8	2,500	no. 25	23	340	180	516	4.00
	LXKW 1-10	4,000	no. 25	27	340	180	569	6.00
	LXKW 1-13	6,700	no. 25	27	340	180	629	7.80
	LXKW 1-16	10,000	no. 25	33	340	180	688	12.70

\* May also be used with a 5mm chain if load capacity is adjusted accordingly.

**Example:** LXKW 1-10 may be used for I-leg chain slings with a 10 mm chain.

# pewag L XKW 2 Oversize clevis master set

## Two-way strength.

II-leg chain slings in the assembled system are created easily and quickly using this oversize clevis master set, as the chain may be attached directly to the captive coupling of the shortening element, which eliminates the need for an additional connecting element. Assembly and disassembly of the system by a competent person is easy and quick, without the need for special tools.

The hook functions both as a connecting link and a shortening element and the master link is suitable for crane hooks no. 25 according to DIN 15401. The set itself complies with EN 818-4 and has the mechanical values of G10. Due to its large master ring, it is frequently used on mobile cranes.

Other quality features in true pewag style include CE marking, BG approval and a full operating manual. The coupling pin and the lock pin are available as a KBSW spare parts set.



LXKW 2 Oversize clevis master set	Code	Load capacity 0° – 45° / 45° – 60° [kg]	Can be used up to single hook acc. to DIN 15401	d [mm]	t [mm]	w [mm]	e [mm]	Weight [kg/pc.]
	LXKW 2-6 *	2,000 / 1,400	no. 25	23	340	180	478	4.14
	LXKW 2-8	3,550 / 2,500	no. 25	23	340	180	516	4.80
	LXKW 2-10	5,600 / 4,000	no. 25	27	340	180	569	7.60
	LXKW 2-13	9,500 / 6,700	no. 25	33	340	180	629	13.50
	LXKW 2-16	14,000 / 10,000	no. 25	40	340	180	688	21.90

\* May also be used with a 5 mm chain if load capacity is adjusted accordingly.

**Example:** LXKW 2-10 may be used for II-leg chain slings with a 10 mm chain.

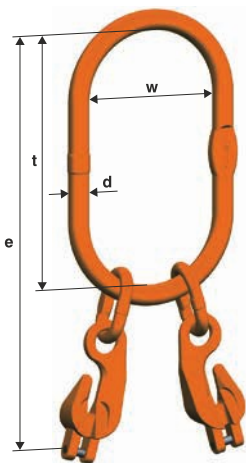

## pewag L XKW 4 Oversize clevis master set

### Right and tight – times four.

This high-grade clevis master set was designed for the creation of IV-leg chain slings in the assembled system. The benefits of this system brook no argument: the chain can simply be mounted directly in the captive coupling of the shortening element, thereby eliminating the need for an additional connecting link. The hook functions both as a connecting link and a shortening element and the master link is suitable for crane hooks no. 25 according to DIN 15401.

A full operating manual instructs competent person in the assembly of the set, without any need for special tools. The set is manufactured according to EN 818-4 with the mechanical values of G10 and, because of its large master ring, it is frequently used on mobile cranes that must withstand multiple loads.

The coupling pin and the lock pin are available as a KBSW spare parts set. CE marking and BG approval are part of our standard programme.



LXKW 4 Oversize clevis master set	Code	Load capacity 0° – 45° / 45° – 60° [kg]	Can be used up to single hook acc. to DIN 15401	d [mm]	t [mm]	w [mm]	e [mm]	Weight [kg/pc.]
	LXKW 4-6 *	3,000 / 2,120	no. 25	23	340	180	478	4.70
	LXKW 4-8	5,300 / 3,750	no. 25	27	340	180	532	7.60
	LXKW 4-10	8,000 / 6,000	no. 25	33	340	180	584	13.10
	LXKW 4-13	14,000 / 10,000	no. 25	40	340	180	659	23.10
	LXKW 4-16	21,200 / 15,000	no. 25	40	340	180	713	33.10

\* May also be used with a 5 mm chain if load capacity is adjusted accordingly.

**Example:** LXKW 4-10 may be used for IV-leg chain slings with a 10 mm chain.

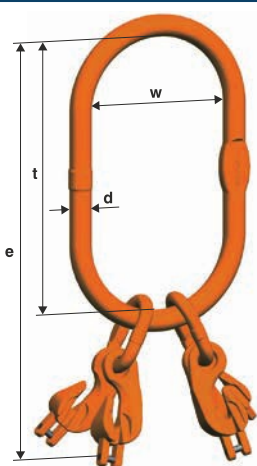

# Accessories in G10

## Product overview

### Content

Connecting links	58-59
Round sling connecting link, Load distributor	60-61
Eye sling hook, Safety hook	62-63
Swivel safety hook	64-65
Swivel hooks, Foundry hook	66-67
Grab hook, Grab hook with safety catch	68-69
Clevis shortening hook, Sheet metal plate hook	70-71
Fork hooks, Shackles	72-74
Toggle, Coupling ring, Clevis reeving link	75-77
Clevis sling hooks, Clevis C hook	78-80
Clevis safety hook, Clevis foundry hook, Clevis grab hook with safety catch	81-84
Clevis shackle, Weld-on hook	85-86
Transition assemblies	88-89







# pewag CW Connex connecting link

## For a flawless connection.

This universal connecting link consists of two symmetrical, die-forged halves, one bolt and one safety sleeve. For the expert connection of master ring and chain, chain and chain, chain and hook, master ring and hook and much more! Please note that the product is suitable for straight pull only and must be assembled by a competent person. Thanks to the sophisticated design, no special tool is required.

To maintain the high quality of this product, we recommend replacing the pin and tension sleeve after three assemblies/disassemblies. CBHW spare parts sets with pins and tension sleeves are particularly recommended. The product is manufactured according to EN 1677-1 with mechanical values for G10.

BG approval and CE marking are included. A full operating manual is also supplied.

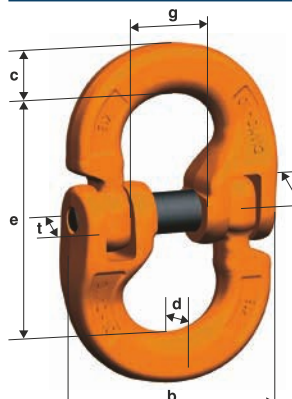

CW Connex connecting link	Code	Load capacity [kg]	e [mm]	c [mm]	s [mm]	t [mm]	d [mm]	b [mm]	g [mm]	Weight [kg/pc.]
	CW 5	1,000	38	7	9	12	7	34	13	0.06
	CW 6	1,400	44	8	11	13	8	39	14	0.08
	CW 7	1,900	53	10	13	16	9	46	17	0.14
	CW 8	2,500	62	12	14	20	10	55	19	0.24
	CW 10	4,000	72	15	18	22	13	64	24	0.42
	CW 13	6,700	88	20	22	26	17	79	28	0.85
	CW 16	10,000	112	24	29	35	24	105	34	1.90
	CW 19/20	16,000	126	32	35	45	25	123	44	3.10
	CW 22	19,000	157	36	39	46	26	148	52	4.60
	CW 26	26,500	190	40	46	49	30	175	60	6.80
	CW 32	40,000	206	47	56	63	35	216	80	11.20

Assembly:

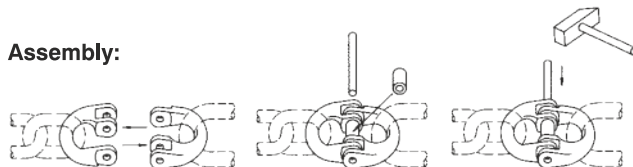

# pewag CLW Connex connecting link

## Form and function.

This universal connection link is manufactured from high-grade material. This product owes its outstanding quality and expediency to a sophisticated manufacturing process. Two symmetrical, die-forged halves and a special safety set ensure universal combination options of master ring/chain, chain/chain, chain/hook, master ring/hook and other elements.

The CLW Connex connecting link is suitable for straight pull only and cannot be dismantled after assembly. The link may be assembled by a competent person easily and quickly, without the need for special tools. Manufactured according to EN 1677-1 with the mechanical values of G10. Recommended for applications where the pin cannot be removed once assembled, for instance magnetic slings or concrete buckets.

The special safety kit is available as a CLBHW spare parts set. Product includes CE marking, BG approval and a full operating manual.



CLW Connex connecting link	Code	Load capacity [kg]	e [mm]	c [mm]	s [mm]	t [mm]	d [mm]	b [mm]	g [mm]	Weight [kg/pc.]
	CLW 7	1,900	53	10	13	16	9	46	17	0.14
	CLW 10	4,000	72	15	18	22	13	64	24	0.42
	CLW 13	6,700	88	20	22	26	17	79	28	0.85
	CLW 16	10,000	112	24	29	35	24	105	34	1.90

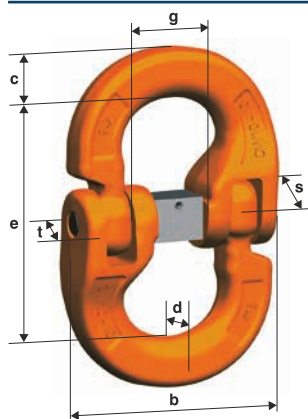

# pewag CARW Round sling connecting link

## Safely connected.

Extra-safe round sling connecting links are required for the assembly of round slings or webbing slings, with a wide, protecting layer for round slings and webbing slings. The CARW round sling connecting link is manufactured according to EN 1677-1 with the mechanical values of G10 and fulfils these requirements down to the smallest detail. It is easily assembled and disassembled by a competent person, without the need for special tools.

It is recommended to use a new pin and tension sleeve after three assemblies/disassemblies. Also note that this product is suitable for straight pull only. The product comes with Connex halves, pin and tension sleeve, which are also available as a CBHW spare parts set.

Includes CE-marking, BG approval and full operating manual.



CARW Round sling connecting link	Code	Load capacity [kg]	a [mm]	e [mm]	c [mm]	d [mm]	b [mm]	s [mm]	g [mm]	Weight [kg/pc.]
	CARW 8	2,500	29	66	12	10	68	18	19	0.40
	CARW 10	4,000	40	81	15	13	82	21	24	0.55
	CARW 13	6,700	44	104	20	17	101	28	28	1.20
	CARW 16	10,000	47	113	24	24	110	40	34	2.00
	CARW 22	19,000	110	190	36	36	215	58	52	8.82

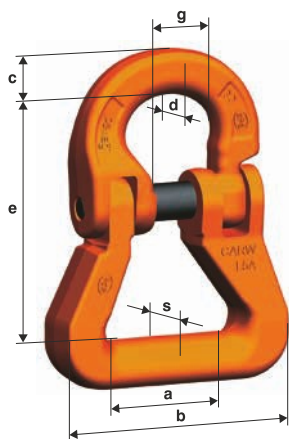

# pewag AGWW Load distributor

## Your load just got lighter.

A bonus for all specialist users! As this system offers a higher load capacity compared to standard IV-leg slings, it is all about the load capacity of the master link assembly. The load distributor may be turned by 180° once the elimination criteria have been reached, thereby doubling its lifespan!

The system is used for assembling IV-leg chain slings with Connex connecting links. Where required, all four legs may be considered load-carrying:

If two II-leg slings are used at the same time and one of them is provided with a load distributor, this system may also be treated as a IV-leg sling with four load-carrying legs. Please consult the operating manual for more detailed information.



	Code	Connex*	WLL 0° – 45° [kg]	WLL 45° – 60° [kg]	a [mm]	e [mm]	d1 [mm]	d2 [mm]	h [mm]	h1 [mm]	s [mm]	Difference L1/L2 [chain links]	Weight [kg/pc.]
	AGWW 5/6	CW 8	2,000	1,400	148	35	16	22	11	9	10	6 for 5 mm chain 5 for 6 mm chain	0.54
	AGWW 7/8	CW 10	3,550	2,500	210	51	22	25	15.50	14	15	6 for 7 mm chain 5 for 8 mm chain	1.75
	AGWW 10	CW 13	5,600	4,000	180	32	25	32	23	15.50	15	4	1.56
	AGWW 13	CW 16	9,500	6,700	240	53	32	40	27	20	20	4	3.60
	AGWW 16	CW 19/20	14,000	10,000	300	77	40	50	32	25	25	4	7.18
	AGWW 19/20	CW 32	20,000	14,000	390	79	50	70	45	30	30	5	13.20
	AGWW 22	CW 32	26,500	19,000	350	124	60	70	50	35	30	5	14.70
	AGWW 26	**)	37,500	26,500	400	130	70	75	60	40	40	5	28.80

\* Please use this Connex to assemble the load distributor in the four-leg sling.  
Static test bow coefficient = 2.5 x load capacity of the respective chain section; safety factor = 4

\*\* ) Bow shackle VB G-4163 WLL 55 to



application video

# pewag HSW Eye sling hook

## Resilience has a name.

This eye sling hook offers universal options for usage and is manufactured with a forged safety catch that locks into the tip of the hook, thereby offering increased protection against lateral shifts. The hook is suitable for Connex and the welded system and is manufactured according to EN 1677-2 with the mechanical values of G10.

Like all pewag components, this eye sling hook is a high-grade manufacturing product. It comes with a safety catch set with a rust-proof spring and safety sleeve and may be assembled quickly, without the need for special tools. The safety catch ensures that all-important safety bonus. However, please note that the product is suitable for straight pull only. Loads must not be placed on the tip of the hook or the safety catch! Includes CE-marking, BG approval and full operating manual.

The safety catch set SFGW is also available as a spare parts set.

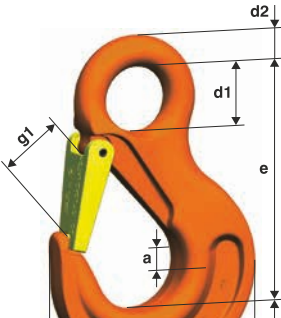

HSW Eye sling hook	Code	Load capacity [kg]	e [mm]	h [mm]	a [mm]	d1 [mm]	d2 [mm]	g1 [mm]	b [mm]	Weight [kg/pc.]
	HSW 5/6	1,400	85	21	17	20	10	19	68	0.30
	HSW 7/8	2,500	106	27	19	25	11	26	88	0.50
	HSW 10	4,000	131	33	26	34	16	31	109	1.10
	HSW 13	6,700	164	44	33	43	19	39	134	2.20
	HSW 16	10,000	183	50	40	50	25	45	155	3.50
	HSW 19/20	16,000	205	55	48	55	27	53	178	5.80
	HSW 22	19,000	225	62	50	60	29	62	196	8.00
	HSW 26	26,500	259	75	70	70	37	73	235	13.40
	HSW 32	40,000	299	97	82	66	45	87	291	27.50

# pewag LHW Safety hook

## Automatic safety.

Safe by name, safe by nature – this hook closes and locks automatically, which means that it cannot open when under load. It is perfect in combination with the Connex system and also offers additional, universal connection options thanks to the flattened section on the eye. As it comes with a wider jaw opening than HSW, it may be used much more flexibly.

Please note that this hook is suitable for straight pull only. The tip of the hook and the safety catch must not be placed under load and the hook should not be used in the welded system.

If used correctly, assembly of this safety hook is simple and does not require any special tools. The hook corresponds to EN 1677-3, with the mechanical values of G10, and comes with a full operating manual, CE marking and BG approval.

The safety catch set VLHW on the back of the hook is also available as a spare parts set.

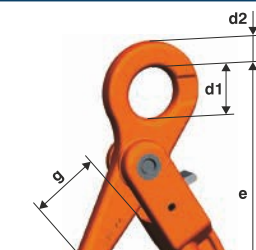

LHW Safety hook	Code	Load capacity [kg]	e [mm]	h [mm]	a [mm]	b [mm]	d1 [mm]	d2 [mm]	g [mm]	s max. [mm]	Weight [kg/pc.]
	LHW 5/6	1,400	110	20	17	71	21	11	28	1	0.50
	LHW 7/8	2,500	136	26	20	88	25	12	34	1	0.90
	LHW 10	4,000	169	30	29	107	35	15	45	1	1.50
	LHW 13	6,700	205	40	35	138	40	20	52	1.50	2.70
	LHW 16	10,000	251	50	41	168	50	27	60	2	5.70
	LHW 19/20	16,000	290	62	50	194	60	30	70	2	9.80
	LHW 22	19,000	322	65	52	211	70	32	81	2	12.40

# pewag WLHW Swivel safety hook

## Stable and versatile.

This hook is at its best when used with the Connex system. It closes and locks automatically and cannot be opened while under load. The large swivel casing opens up an even wider range of application options and the larger jaw opening compared to HSW means that it may be used more flexibly. When it comes to quality, this hook is in a league of its own: It comes with CE marking and BG approval, complies with EN 1677-3 and has the mechanical values of G10.

A detailed operating manual provides information on the wide range of possible applications. But be careful – the hook is only suitable for straight pull and cannot be rotated when under load. Also note that the tip of the hook and the safety catch must not be placed under load and the hook should not be used in the welded system.

Assembly of the safety catch is easy and quick, without the need for special tools.

The safety catch set VLHW which forms the locking mechanism on the back of the hook is also available as a spare parts set.



WLHW Swivel safety hook	Code	Load capacity [kg]	e [mm]	h [mm]	a [mm]	w [mm]	w1 [mm]	d2 [mm]	g [mm]	s max. [mm]	Weight [kg/pc.]
	WLHW 5/6	1,400	161	20	17	35	36	12	28	1	0.78
	WLHW 6*	1,400	160	20	17	35	35	13	28	1	0.60
	WLHW 7/8	2,500	182	26	20	35	36	12	34	1	1.10
	WLHW 10	4,000	218	30	29	42	41	16	45	1	2.00
	WLHW 13	6,700	269	40	35	49	47	20	52	1.5	4.00
	WLHW 16	10,000	319	50	41	60	60	24	60	2	6.80

\* Discontinued article

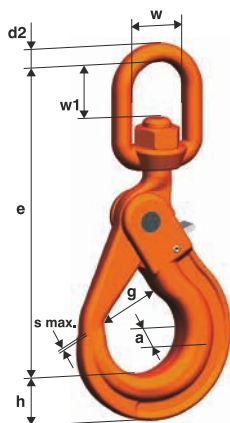



# pewag WLHBW Swivel safety hook

## Rotates even under load.

This showpiece can withstand operating temperatures of up to 120 °C. The swivel safety hook closes and locks automatically and comes with an axial bearing, ensuring that it may be rotated when under load, but not opened. It is suitable for Connex systems and also offers additional connecting options thanks to its large swivel casing. Its jaw opening is larger than the HSW eye hook, making it more flexible in terms of potential use.

Please note that the product is suitable for straight pull only. Also note that the tip of the hook and the safety catch must not be placed under load and the hook should not be used in the welded system. Quality features include CE marking and BG approval, compliance with EN 1677-3 and the mechanical values of G10.

Assembly of the locking set is easy and quick and does not require any special tools. A replacement bearing unit and full operating manual are available. The safety catch set VLHW which forms the locking mechanism on the back of the hook is also available as a spare parts set.



WLHBW Swivel safety hook	Code	Load capacity [kg]	e [mm]	h [mm]	a [mm]	w [mm]	w1 [mm]	d2 [mm]	g [mm]	s max. [mm]	Weight [kg/pc.]
	WLHBW 5/6	1,400	161	20	17	35	36	12	28	1	0.78
	WLHBW 6*	1,400	160	20	17	35	35	13	28	1	0.60
	WLHBW 7/8	2,500	182	26	20	35	36	12	34	1	1.10
	WLHBW 10	4,000	218	30	29	42	41	16	45	1	2.00
	WLHBW 13	6,700	269	40	35	49	47	20	52	1.5	4.00
	WLHBW 16	10,000	319	50	41	60	60	24	60	2	6.80

\* Discontinued article

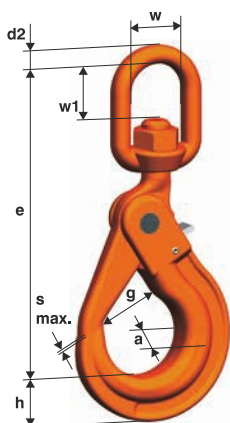

# pewag WSBW Swivel hook

## Hooked on safety.

CE marking and BG approval are essential features of this pewag safety component. The swivel hook may be used universally and comes with a die-forged safety catch that locks into the tip of the hook, thereby providing excellent protection against lateral shifts.

The WSBW swivel hook is suitable for the Connex systems, but also offers numerous other universal connection options thanks to its large swivel casing. Rotatability under load is ensured by an axial bearing design and comes as a special plus. The maximum operating temperature for this product is 120 °C. The product is manufactured according to EN 1677-2 with the mechanical values for G10.

This product is suitable for straight pull only. Also note that the tip of the hook and the safety catch must not be placed under load. The swivel hook should not be used in the welded system. Assembly of the safety catch set is simple and quick and does not require any special tools. It consists of a die-forged safety catch, a rust-proof spring and a safety sleeve – after all, all good things come in threes!

A full operating manual contains everything you need to know about the versatile application options of this swivel hook. The safety catch set SFGW is also available as a spare parts set.



WSBW Swivel hook	Code	Load capacity [kg]	e [mm]	h [mm]	a [mm]	d1 [mm]	d2 [mm]	g1 [mm]	Weight [kg/pc.]
	WSBW 7/8	2,500	154	28	19	37	12	26	0.85
	WSBW 10	4,000	183	33	25	41	16	30	1.56
	WSBW 13	6,700	221	40	30	47	20	38	2.71

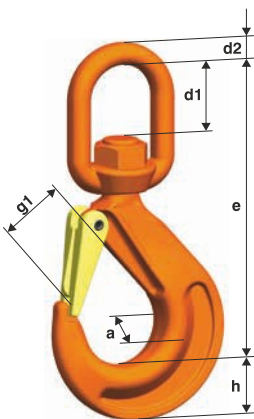

# pewag FW Foundry hook

## Jaw size matters.

This hook comes with an extra-wide jaw and is used in applications where other hooks simply aren't up to the job. The model is frequently used in foundries and also does an excellent job when used with Connex and welded systems.

The product is manufactured according to EN 1677-1 with the mechanical values of G10 and comes with a full operating manual. CE marking and BG approval ensure quality of the highest order.

This extra-wide hook has a lot to offer – but please avoid tip loading and ensure that it is used in straight pull only. Please check whether use without the safety catch is admissible prior to each use.

The product is not suitable for assembly with Unilock connecting elements.



FW Foundry hook	Code	Load capacity [kg]	e [mm]	h [mm]	a [mm]	d1 [mm]	d2 [mm]	g [mm]	b [mm]	Weight [kg/pc.]
	FW 7/8	2,500	131	29	25	24	11	64	118	0.92
	FW 10	4,000	158	35	32	31	14	76	143	1.77
	FW 13	6,700	190	42	40	39	17	89	170	2.82
	FW 16	10,000	224	50	46	47	22	102	200	5.03
	FW 19/20	16,000	260	61	54	56	28	114	231	9.24
	F 22	15,000	265	70	61	47	30	127	260	9.31
	F 26 *	21,200	305	80	72	54	34	136	280	19.21
	F 32	31,500	327	93	83	60	37	152	336	28.00

\* Not suitable for assembly with Unilock.

# pewag PW Grab hook

## Heavy-duty with a twist.

Thanks to the special design of the chain contact area, this standard shortening hook ensures optimal interaction between chain and hook. Even when shortened, the load capacity is not reduced.

The product comes with a full operating manual and is suitable for use with Connex and the welded system and can also be retrofitted. It complies with EN 1677-1 with the mechanical values for G10 and comes with CE marking. Please note that it is not suitable for tip loading and can not be used with Unilock connecting links.

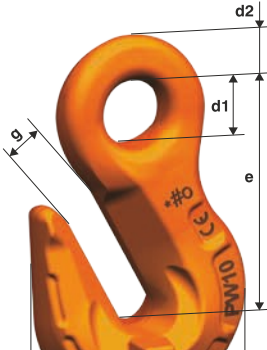

PW Grab hook	Code	Load capacity [kg]	e [mm]	b [mm]	d1 [mm]	d2 [mm]	g [mm]	Weight [kg/pc.]
	PW 5	1,000	47	40	11	9	7	0.13
	PW 6	1,400	50	44	12	9	7	0.15
	PW 7/8	2,500	65	57	16	12	9	0.37
	PW 10	4,000	77	71	20	14	12	0.70
	PW 13	6,700	101	92	26	19	15	1.56
	PW 16	10,000	121	113	32	23	19	2.90
	PW 19/20 *	16,000	151	150	36	27	25	6.15
	PW 22 *	19,000	170	165	42	31	27	8.30
	PW 26 *	26,500	201	195	50	37	32	13.80
	PW 32 *	40,000	243	242	60	43	38	25.40

\* Shape without saddle

Shape without saddle:

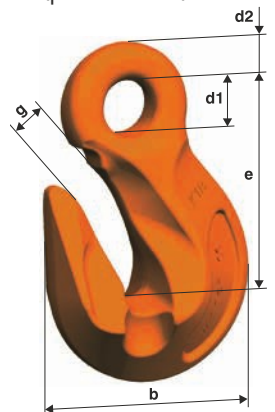

### pewag – one step ahead, also in terms of design.

pewag sets great store by the further development of its product range and far exceeds market expectations in this respect. A lot of progress has been made in terms of design and appearance, and it is now even easier to recognise when exactly the pewag winner chain is fitted correctly. However, it is important to emphasise that, for technical reasons, the chain must not touch the bearing surface of the pewag grab hook or clevis grab hook. The winner chain is in fact supported by the side faces of the pewag grab hook, thus ensuring the high safety standard that all pewag products have in common when handled correctly.

Note: This is applicable for grab hooks without saddles and as well for the XKW (page 66)



# pewag PSW Grab hook with safety catch

## All-round safety at all times.

This standard shortening hook ensures optimal interaction between chain and hook thanks to the special design of the chain contact area. Moreover, the integrated safety catch protects the chain from an accidental release. Tip loading is not allowed as well as the assembling with Unilock connecting links. Further, the usage in the welded system has to be prevented.

Even when shortened, the load capacity is not reduced. The product comes with a full operating manual and is compatible with the Connex system and can also be retrofitted. It complies with EN 1677-1 with the mechanical values for G10 and comes with CE marking.

The safety catch is also available as a spare part. The PSGW spare parts set consists of pin, spring and nut.



PSW Grab hook with safety catch	Code	Load capacity [kg]	e [mm]	b [mm]	d1 [mm]	d2 [mm]	g [mm]	Weight [kg/pc.]
	PSW 7/8	2,500	65	57	16	12	9	0.37
	PSW 10	4,000	77	71	20	14	12	0.70
	PSW 13	6,700	101	92	26	19	15	1.56
	PSW 16	10,000	121	113	32	23	19	2.90

# pewag XKW Clevis shortening hook

## Ready for anything.

This shortening hook is ideally suited for the Connex and welded system. Thanks to its clevis connecting link, it may be mounted directly into the chain. The eye on the upper surface of the hook makes it suitable for universal connections and applications as a hook in VXKW and LXKW chain slings. For details, please refer to the full operating manual that comes with the product.

The clevis shortening hook is manufactured according to EN 1677-1 with the mechanical values of G10 and comes with a CE marking for certified quality and BG approval. Please note that tip loading is not permitted. If handled by a competent person, assembly is quick and easy and does not require any special tools.

The coupling pin and the lock pin are available as a KBSW spare parts set.



XKW Clevis shortening hook	Code	Load capacity [kg]	e [mm]	b [mm]	a [mm]	d1 [mm]	d2 [mm]	g [mm]	Weight [kg/pc.]
	XKW 5/6	1,400	84	37	29	18	9	8	0.30
	XKW 7	1,900	122	54	39	24	12	11	0.62
	XKW 8	2,500	122	54	39	24	12	11	0.63
	XKW 10	4,000	159	70	50	31	14	13	1.25
	XKW 13	6,700	203	92	64	37	18	15	2.70
	XKW 16	10,000	234	102	80	48	24	20	4.80

# pewag BWW Sheet metal plate hook

## The perfect lift.

The lifting of sheet metal stacks, boards etc. requires perfect tools - and the BWW sheet metal plate hook is one of them. It can also be supplied in customised dimensions upon request. As a standard, it may be used with Connex and the welded system and corresponds with EN 1677-1 with the mechanical value of G10.

Please note that the product is not suitable for tip loading and that the hooks must be fully pushed onto the load. A minimum III-leg chain sling is recommended, with an ideal inclination angle of 15° to 30°. WLL must be given as that for a II-leg sling.

The sheet metal plate hook comes with CE marking and a full operating manual.

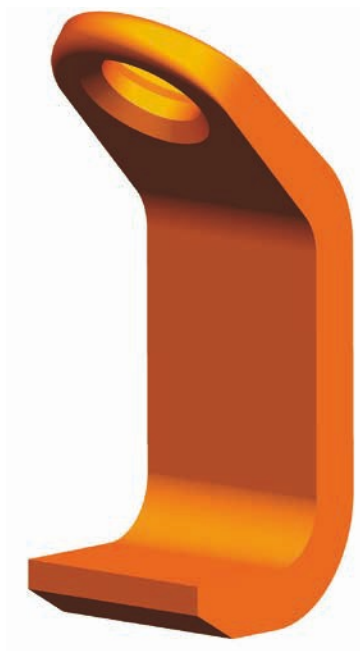

BWW Sheet metal plate hook	Code	Load capacity [kg]	e [mm]	s [mm]	b [mm]	h [mm]	d1 [mm]	g [mm]	Weight [kg/pc.]
	BWW 7/8	2,500	131	80	50	15	28	55	1.20
	BWW 10	4,000	170	100	70	20	36	65	2.89
	BWW 13	6,700	209	130	80	25	40	90	5.23
	BWW 16	10,000	263	160	100	30	50	110	9.79
	BWW 19/20	16,000	306	185	120	40	60	130	18.39
	BWW 22	19,000	368	220	140	50	75	150	31.65

Custom designs are available upon request!

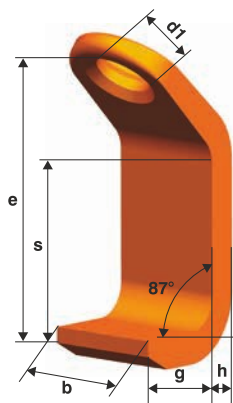

# pewag GHW Fork hook

Also available with customised dimensions.

Safety is key when it comes to lifting sheet metal stacks, plates etc. The GHW fork hook ticks all the boxes: It makes a great partner for Connex and welded systems and is available in customised dimensions upon request. In addition, it comes with CE marking, complies with EN 1677-1 and has the mechanical values of G10.

Tip loading must be avoided and care must be taken to ensure that the hooks are fully pushed onto the load. The hooks must always be used in pairs, with a sling inclination angle of 30° to 45°.

For details, please refer to the full operating manual.



Code	Load capacity [kg]	s [mm]	b [mm]	g [mm]	d [mm]	e [mm]	BW-link	Weight [kg/pc.]
GHW 5/6	1,400	100	190	65	23	203	BW 13	2.80
GHW 7/8	2,500	150	254	100	30	300	BW 16	6.50
GHW 10	4,000	200	380	130	40	402	BW 22	16.10

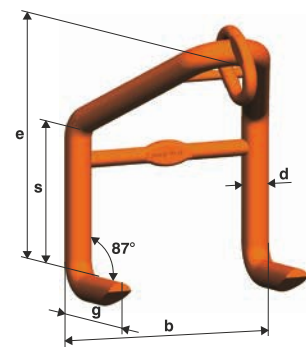

Custom designs are available upon request!



# pewag SCHW Shackle

## Tried and tested.

This is yet another quality product that is tested to within an inch of its life before being launched on the market. This high-strength shackle with a stud bolt in grade 10 and marked accordingly prevents mix-ups and is suitable for general lifting purposes. Both sides of the smooth bolt rest in the eyes and the thread does not protrude into the opening of the shackle. Please check that the bolt is sitting tightly prior to each lifting operation. If this precaution is observed, the shackle can cope with even the most demanding lifting operations. However, please note that the shackle cannot be mounted directly into the chain.

Every single one of these safety products comes with CE marking and a full operating manual.

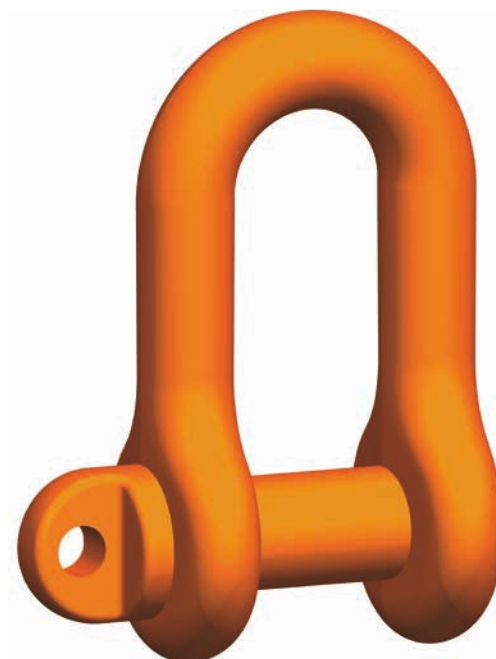

SCHW Shackle	Code	Load capacity [kg]	e [mm]	b [mm]	a [mm]	d1 [mm]	c [mm]	d2 [mm]	Weight [kg/pc.]
	SCHW 5	1,000	24	11	7	8	16	8	0.05
	SCHW 6	1,400	30	14	8	10	20	10	0.09
	SCHW 7/8	2,500	36	17	10	12	24	12	0.20
	SCHW 10	4,000	49	21	13	15	32	16	0.30
	SCHW 13	6,700	61	27	17	19	40	20	0.70
	SCHW 16	10,000	73	33	21	23	48	24	1.30

# pewag GSCHW Curved shackle

## Uncompromising quality.

This high-strength, curved shackle with a grade 10 stud bolt, special thread bolt and corresponding markings is ideally suited for all kinds of general lifting processes, without the risk of mix-ups.

Both sides of the smooth bolt rest in the eyes and the thread does not protrude into the opening of the shackle. Please check that the bolt is sitting tightly prior to each lifting operation. The shackle cannot be mounted directly into the chain.

This pewag product comes with CE marking and a full operating manual.



GSCHW Shackle	Code	Load capacity [kg]	e [mm]	b [mm]	b1 [mm]	a [mm]	c [mm]	d2 [mm]	Weight [kg/pc.]
	GSCHW 7/8	2,500	51	22	32	13	34	16	0.35
	GSCHW 10	4,000	64	27	43	16	40	19	0.64
	GSCHW 13	6,700	76	31	51	19	46	22	1.03
	GSCHW 16	10,000	95	43	68	25	59	28	2.23

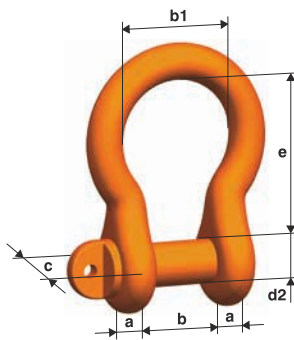

# pewag KNEW Toggle

## Popular in the construction industry.

Thanks to its special low design, this toggle is frequently used for general transportation purposes in the construction industry, for instance of sheet piles. As the toggle is welded into the sling with the next size up chain link, it takes up little space and is also suitable for small bores.

Please refer to the table for the minimum and maximum bore diameter (d).

Also available in other designs upon request.

The toggle is manufactured according to EN 1677-1 with mechanical values according to G10 and full operating manual.

We recommend using a 10 mm chain for the transportation of standing sheet piles.



	Code	for chain	Load capacity [kg]	e [mm]	a [mm]	b [mm]	c [mm]	d1 [mm]	d min. [mm]	d max. [mm]	Connecting link
KNEW Toggle	KNEW 8	8	2,500	10	17	120	38	15	40	60	WIN 10

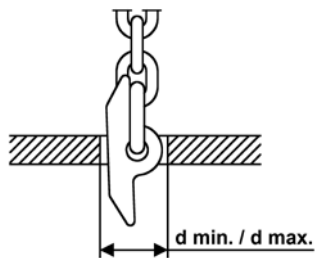
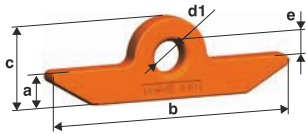

# pewag KRW Coupling ring

## A ring for all seasons.

This coupling ring is also flexible when it comes to customised applications and is a component of the clevis master links KAGW and KMGW. It is manufactured according to EN 1677-1 with mechanical values for G10.

The ring may be assembled easily and quickly by a competent person, without the need for special tools. A full operating manual is available.

The coupling pin and the retaining pin are available as a KBSW spare parts set.

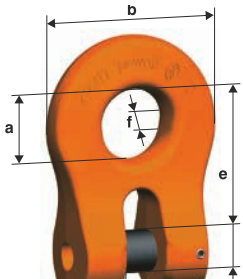

KRW Coupling ring	Code	Load capacity [kg]	e [mm]	s [mm]	a [mm]	b [mm]	f [mm]	d [mm]	Weight [kg/pc.]
	KRW 5/6	1,400	31	7	18	38	8	7.40	0.08
	KRW 7	1,900	43	10	24	54	11	9	0.20
	KRW 8	2,500	43	10	24	54	11	10	0.20
	KRW 10	4,000	51	12	28	63	14	12.50	0.36
	KRW 13	6,700	63	15	33	76	17	16	0.70
	KRW 16	10,000	74	18	40	88	20	20	1.21
	KRW 19/20	16,000	94	23	50	114	24	24	2.38
	KRW 22	19,000	102	25	50	122	27	27	3.21

# pewag KOW Clevis reeving link

## All's well that couples well.

When it comes to quality, we offer no compromises – the middle ground is not where we operate. We specialise in practical, serviceable products – and the KOW clevis reeving link is one of them.

The high-strength, die-forged coupling eye serves to establish a direct connection with the chain. The link may also be used as an end link. No connecting link is required. This powerful package comes with BG approval, CE marking and a full operating manual and is manufactured according to EN 1677-1 with the mechanical values for G10.

The link may be assembled by a competent person easily and quickly, without the need for special tools. If individual components need to be exchanged, the system offers yet another bonus: The coupling pin and the retaining pin are available as a KBSW spare parts set!

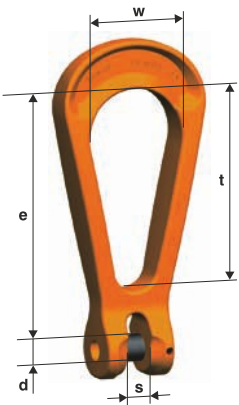

KOW Clevis reeving link	Code	Load capacity [kg]	e [mm]	t [mm]	w [mm]	d [mm]	s [mm]	Weight [kg/pc.]
	KOW 7	1,900	92	70	34	9	9	0.28
	KOW 8	2,500	91	70	34	10	9	0.30
	KOW 10	4,000	128	102	50	12.50	12	0.70
	KOW 13	6,700	169	136	66	16	15	1.40
	KOW 16	10,000	214	172	83	20	18	2.74

## pewag KHSW Clevis sling hook

### By hook (no crook).

If you are looking for an easy, simple chain connection using a clevis system and without any connecting links, this universal sling hook with a forged safety catch is your best bet. The safety catch locks into the tip of the hook, thereby providing excellent protection against lateral shifts.

The clevis sling hook is manufactured in accordance with EN 1677-2 with the mechanical values for G10, comes with BG approval and CE marking and guarantees top performance under straight pull only.

A competent person will require no special tools for the quick and easy assembly of the chain. A full operating manual is provided. The safety catch set consists of a die-forged safety catch, a rust-proof spring and a safety sleeve, all of which are easy to assemble, without the need for special tools.

Spare parts are also easy to come by: The coupling pin and the retaining pin are available as a KBSW spare parts set. The SFGW safety catch set may also be used as a spare part.

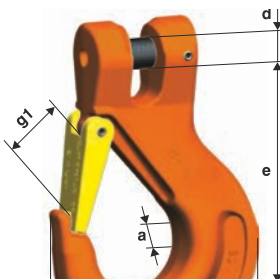

KHSW Clevis sling hook	Code	Load capacity [kg]	e [mm]	h [mm]	a [mm]	d [mm]	g1 [mm]	b [mm]	Weight [kg/pc.]
	KHSW 5/6	1,400	69	20	15	7,40	19	66	0.20
	KHSW 7	1,900	95	28	19	9	26	90	0.60
	KHSW 8	2,500	95	28	19	10	26	90	0.60
	KHSW 10	4,000	109	35	25	12.50	31	108	1.10
	KHSW 13	6,700	136	41	34	16	39	131	2.00
	KHSW 16	10,000	155	49	37	20	45	153	3.48
	KHSW 19/20	16,000	184	53	51	24	53	177	5.00
	KHSW 22	19,000	214	62	52	27	62	196	9.00

# pewag BKHSW Oversize clevis sling hook

## Resistance on a large scale.

The safety latch of the BKHSW oversize clevis sling hook locks into the tip of the hook, thereby providing excellent protection against lateral shifts. The jaw opening is significantly larger than that of the standard KHSW, making this product extra-flexible. Forged control markings make it easy to determine discard criteria. The product may be linked to the chain quickly and easily, without the need for an additional connecting element. The product is designed for straight pull only. Care must be taken to protect the tip of the hook and the safety catch against loading. The BKHSW oversize clevis sling hook is easily and quickly assembled by a competent person – no special tools required! The coupling pin and the lock pin are available as a spare parts set. The safety catch set consists of a die-forged safety catch, a rust-proof spring and a safety sleeve.

The product comes with a full operating manual that will answer any other questions you may have. Outstanding quality features include manufacturing according to EN 1677-2 with the mechanical values for G10, BG approval and CE marking. The KBSW spare parts set consists of a coupling pin and retaining pin. The SFGW-B spare parts set consists of a safety catch, spring and safety sleeve.



BKHSW Oversize Clevis Sling Hooks	Code	Load capacity [kg]	e [mm]	h [mm]	a [mm]	d [mm]	g1 [mm]	b [mm]	Weight [kg/pc.]
	BKHSW 8	2,500	93	27	25	10	32	98	0.90
	BKHSW 10	4,000	111	33	30	12.50	38	119	1.50

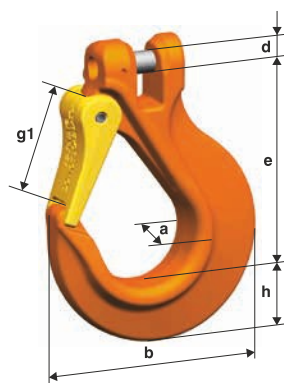

# pewag KCHW Clevis C-hook

## „C“ for charming.

Simple and fast hooking and removal where no safety catch is required – this is where the KCHW clevis C-hook comes into its own! Its hook tip is shaped in such a way as to prevent accidental unhooking when not under load. The chain may be linked to the clevis system easily and speedily, without the need for additional connecting links.

The hook is manufactured in accordance with EN 1677-1 with the mechanical values for G10, comes with BG approval, CE marking and a full operating manual. The KBSW spare parts set consists of a coupling pin and a retaining pin. A competent person will find both the hook and its spare parts set with coupling pin and retaining pin easy and quick to assemble, without the need for special tools.

Provided that it is used under straight pull only and without the tip being loaded, the clevis C-hook is a charming solution indeed.



KCHW Clevis C-hook	Code	Load capacity [kg]	e [mm]	h [mm]	d [mm]	b [mm]	g [mm]	Weight [kg/pc.]
	KCHW 7	1,900	91	28	9	74	20	0.50
	KCHW 8	2,500	90	28	10	74	20	0.50
	KCHW 10	4,000	129	39	12.50	107	28	1.40
	KCHW 13	6,700	166	51	16	137	41	3.00
	KCHW 16	10,000	205	60	20	166	45	5.30

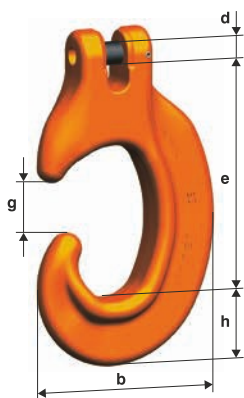



# pewag KLHW Clevis safety hook

## Guaranteed stress-resistant.

This clevis safety hook closes and locks automatically and has a significantly larger jaw opening than the KHSW clevis hook, which makes it much more versatile. The hook corresponds to EN 1677-3 with the mechanical values for G10. For safety reasons, it cannot be opened while under load. Please note that the hook is suitable for straight pull only and that the load must not be placed on the tip of the hook or the safety catch. If these safety requirements are adhered to, the hook is bound to live up to its name!

Assembly is quick and easy and does not require any special tools – however, it must be performed by a competent person. The full operating manual tells you all you need to know about using this product correctly. The hook comes with BG approval, CE marking and exchangeable spare parts. The coupling pin and retaining pin are available as a KBSW spare parts set, as is the VLHW locking set on the back of the hook.

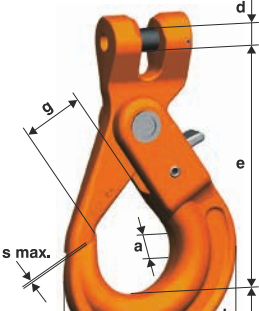

KLHW Clevis safety hook	Code	Load capacity [kg]	e [mm]	h [mm]	a [mm]	b [mm]	d [mm]	g [mm]	s max. [mm]	Weight [kg/pc.]
	KLHW 5/6	1,400	94	20	17	71	7,40	28	1	0.50
	KLHW 7	1,900	123	26	20	88	9	34	1	0.90
	KLHW 8	2,500	123	26	20	88	10	34	1	0.90
	KLHW 10	4,000	144	30	29	107	12.50	45	1	1.60
	KLHW 13	6,700	180	40	35	138	16	52	1.50	2.90
	KLHW 16	10,000	218	50	41	168	20	60	2	5.80
	KLHW 19/20	16,000	259	62	50	194	24	70	2	9.90
	KLHW 22	19,000	286	65	52	211	27	81	2	12.80
	KLHW 26	26,500	338	79	61	253	33	100	2	20.50

# pewag KFW Clevis foundry hook

## Open wide.

If you've got it, flaunt it - the oversize jaw size of the KFW clevis foundry hook plays all the tricks. This hook is frequently used in foundries and is manufactured according to EN 1677-1 with the mechanical values of G10. Other classic pewag quality features include BG approval and CE marking. Yet another typical pewag feature – the clevis system means that linking the hook to the chain is quick and easy, without the need for a connecting element. A full operating manual outlines everything you need to know for efficient and safe handling.

Please note that the hook is suitable for straight pull only and that the load must not be placed on the hook tip. Please check whether use without the safety catch is admissible prior to each use. For a competent person, assembly of the clevis foundry hook is quick and easy and does not require any special tools. Spare parts for the coupling pin and retaining pin are easily procured, thanks to the designated spare parts set.



KFW Clevis foundry hook	Code	Load capacity [kg]	e [mm]	h [mm]	a [mm]	g [mm]	d [mm]	b [mm]	Weight [kg/pc.]
	KFW 7	1,900	121	29	25	64	9	118	1.00
	KFW 8	2,500	120	29	25	64	10	118	1.00
	KFW 10	4,000	140	35	32	76	12.50	143	1.78
	KFW 13	6,700	170	42	40	89	16	170	2.96

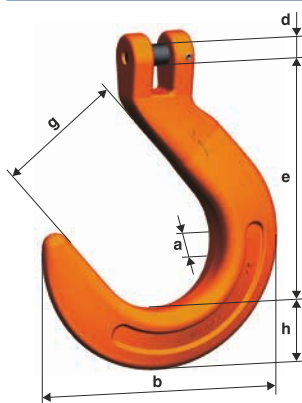

# pewag KPW Clevis grab hook

## Perfect interplay.

This standard shortening hook ensures optimal interaction between chain and hook thanks to the special design of the chain contact. Even when shortened, the load capacity is not reduced and the product is suitable for retrofitting. The clevis system makes it possible to link the chain to the hook quickly and easily, without the need for an additional connecting element. The coupling pin and the retaining pin are available as a KBSW spare parts set.

The clevis grab hook is manufactured according to EN 1677-1 with the mechanical values for G10 and comes with CE marking. As specified in the full operating manual, it is not suitable for tip loading and assembly must always be performed by a competent person to ensure safe usage. No special tools are required for assembling this product.



Code	Load capacity [kg]	e [mm]	b [mm]	d [mm]	g [mm]	Weight [kg/pc.]
KPW 6	1,400	47	47	7.40	7	0.17
KPW 7	1,900	63	57	9	9	0.44
KPW 8	2,500	63	57	10	9	0.44
KPW 10	4,000	78	71	12.50	12	0.85
KPW 13	6,700	93	92	16	15	1.75
KPW 16	10,000	115	113	20	19	3.30
KPW 19/20 *	16,000	141	150	24	25	6.15
KPW 22 *	19,000	158	165	27	27	9.00

KPW Clevis grab hook

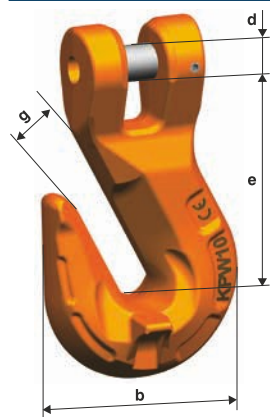

\* Shape without saddle.

Shape without saddle:

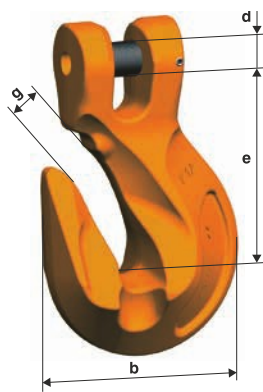

# pewag KPSW Clevis grab hook with safety catch

## Perfect interplay.

This standard shortening hook ensures optimal interaction between chain and hook thanks to the special design of the chain contact, providing extra protection from accidental chain release. Even when shortened, the load capacity is not reduced and the product is suitable for retrofitting. The clevis system makes it possible to link the chain to the hook quickly and easily, without the need for an additional connecting element. The coupling pin and the retaining pin are available as a KBSW spare parts set.

Thanks to its safety mechanism which prevents the accidental unhooking of the chain, this hook is also ideal for securing loads.

The safety set PSGW consists of bolt, spring and nut and is also available as a spare parts set. The clevis grab hook is manufactured according to EN 1677-1 with the mechanical values for G10 and comes with CE marking. As specified in the full operating manual, tip loading must be avoided and assembly must always be performed by a competent person to ensure safe usage. No special tools are required for assembling this product.



KPSW Clevis grab hook with safety catch	Code	Load capacity [kg]	e [mm]	b [mm]	d [mm]	g [mm]	Weight [kg/pc.]
	KPSW 7	1,900	63	57	9	9	0.44
	KPSW 8	2,500	63	57	10	9	0.44
	KPSW 10	4,000	78	71	12.50	12	0.85
	KPSW 13	6,700	93	92	16	15	1.75
	KPSW 16	10,000	115	113	20	19	3.30

# pewag KSCHW Clevis shackle

## The missing link.

This high-performance shackle consists of a special screw, nut and split pin, which makes losing the screw practically impossible. The wide opening makes this shackle extremely versatile – for instance, it may be used on spreader beams. The clevis system makes linking the shackle to the chain quick and simple, without the need for an additional connecting element. The clevis shackle is manufactured according to EN 1677-1 with mechanical values for G10, and comes with a full operating manual, BG approval and CE marking.

Prior to each lifting operation, it must be checked that the safety split pin is in place and that the system is subjected to straight pull only. Lateral forces must not be applied. Assembly must be handled by a competent person. No special tools are required. The KBSW spare parts set consists of coupling pin and retaining pin. The KBMSW spare parts set consists of special screw, nut and split pin.

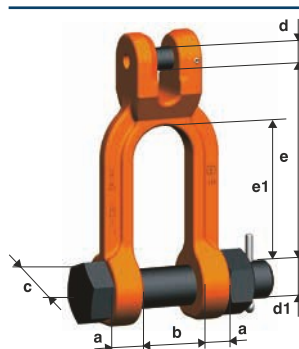

KSCHW Clevis shackle	Code	Load capacity [kg]	e [mm]	e1 [mm]	b min. [mm]	a [mm]	d [mm]	c [mm]	d1 [mm]	Weight [kg/pc.]
	KSCHW 7	1,900	76	54	26	12	9	31	16	0.49
	KSCHW 8	2,500	76	54	26	12	10	31	16	0.49
	KSCHW 10	4,000	105	76	32	16	12.50	39	20	0.95
	KSCHW 13	6,700	113	77	42	21	16	50	24	1.89

# pewag AWHW Weld-on hook

## Welding for winners.

This high-strength hook is particularly well suited for welding onto excavator bucket, spreader beams etc. Its outstanding features include a die-forged, tempered safety catch, making it extra-robust. As the safety catch locks into the tip of the hook, it provides excellent protection against lateral shifting.

The product is manufactured according to EN 1677-1 with a higher load capacity and comes with full operating and welding instructions that must be complied with at all times. A CE marking further emphasises the superior quality of this product. Replacing the SFGW-A safety catch set is easy and quick, without the need for special tools.

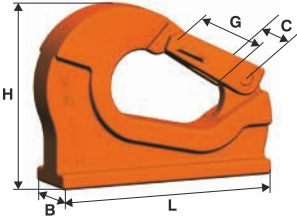

AWHW Weld-on hook	Code	Load capacity [kg]	L [mm]	H [mm]	G [mm]	B [mm]	C [mm]	Weight [kg/pc.]
	AWHW 1.3	1,300	95	74	25	25	34	0.60
	AWHW 3.8	3,800	132	106	29	35	40	1.30
	AWHW 6.3	6,300	167	133	34	45	49	2.80
	AWHW 10	10,000	175	136	34	50	49	3.70

Hardened shell –  
intelligent core

# peTAG solution

A pewag solution that inspires.

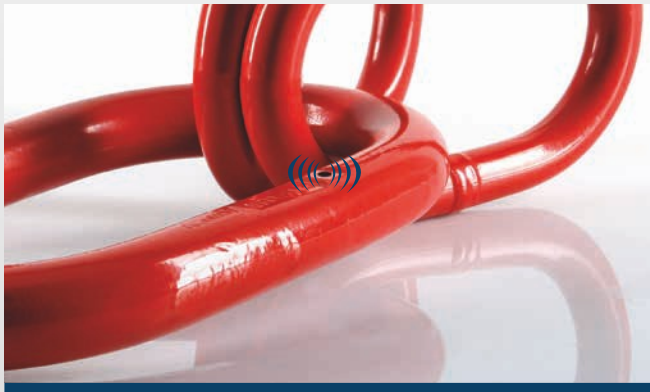

# pewag ÜW Transition assemblies

## For single hooks according to DIN 15401 – smooth transition guaranteed!

Large master rings, combined with CW Connex and HSW eye hooks, make it possible to use smaller rings, thereby opening up a wide range of possible combinations and load capacities, thanks to the modular assembly system. For details, please refer to the full operating manual.

The ÜW transition link is manufactured according to EN 818-4 with the mechanical values for G10 and ensures smooth transitions throughout the pewag product range.

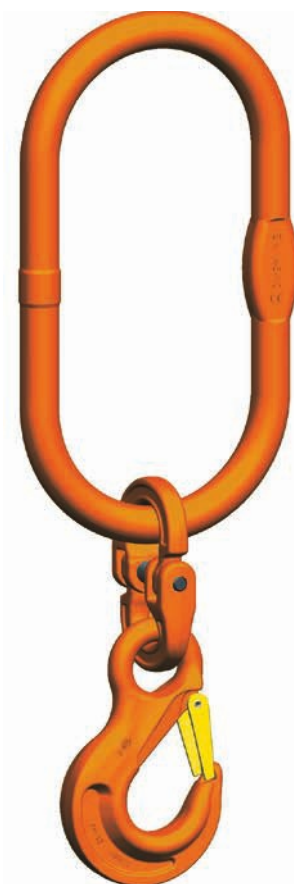

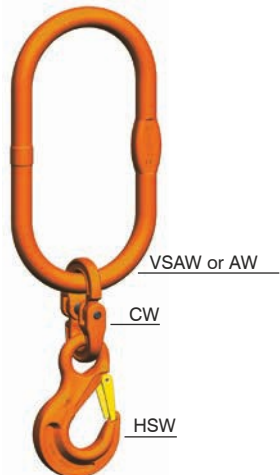
ÜW Transition assembly for single hook	Code	Single hook DIN 15401	Load capacity [kg]	Comprising of	Weight [kg/pc.]
	ÜW 50/4   VSAW-HSW Connex	50	4,000	VSAW 1-16/CW 16/HSW 10	11.80
	ÜW 50/6.7   VSAW-HSW Connex	50	6,700	VSAW 1-16/CW 16/HSW 13	12.90
	ÜW 50/10   VSAW- HSW Connex	50	10,000	VSAW 1-16/CW 16/HSW 16	14.20
	ÜW 32/16   AW-HSW Connex	32	16,000	AW 50/CW 26/HSW 19/20	29.10
	ÜW 32/19   AW-HSW Connex	32	19,000	AW 50/CW 26/HSW 22	31.30
	ÜW 32/26.5   AW-HSW Connex	32	26,500	AW 50/CW 26/HSW 26	36.70
	ÜW 50/16   VSAW-HSW Connex	50	16,000	VSAW 1-22/CW 22/HSW 19/20	27.80
	ÜW 50/19   VSAW-HSW Connex	50	19,000	VSAW 1-22/CW 22/HSW 22	30.00
	ÜW 50/26.5   VSAW-HSW Connex	50	26,500	VSAW 1-26/CW 26/HSW 26	41.10
	ÜW 50/40   AW-HSW Connex	50	40,000	AW 72/CW 32/HSW 32	83.70
	ÜW 100/26.5   VSAW-HSW Connex	100	26,500	VSAW 1-32/320/CW 26/HSW 26	68.10
	ÜW 100/40   VSAW-HSW Connex	100	40,000	VSAW 1-32/320/CW 32/HSW 32	86.70



# pewag ÜW Transition assemblies

## For double hooks according to DIN 15402 – flawless finish.

Large master rings, combined with CW Connex and HSW eye hooks, make it possible to use smaller rings, thereby opening up a wide range of possible combinations and load capacities, thanks to the modular assembly system. For details, please refer to the full operating manual.

The ÜW transition link is manufactured according to EN 818-4 with the mechanical values for G10 and is regarded as a high-quality product that lives up to its name throughout the pewag product range.

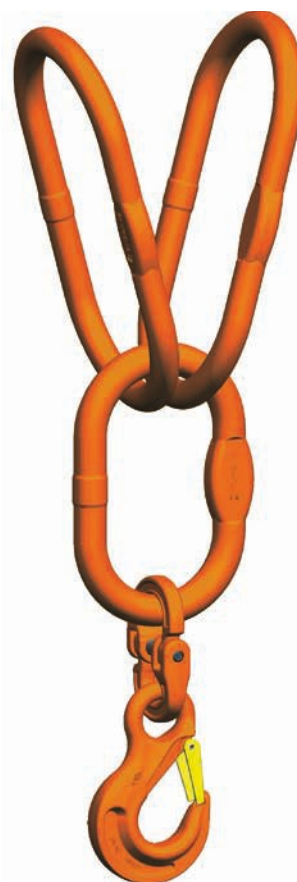

ÜW Transition assembly for double hook	Code	Double hook DIN 15402	Load capacity [kg]	Comprising of	Weight [kg/pc.]
	ÜW 50/4 II VSAW-HSW Connex	50	4,000	2x VSAW 1-16/AW36/ CW16/HSW10	27.40
	ÜW 50/6.7 II VSAW-HSW Connex	50	6,700	2x VSAW 1-16/AW36/ CW16/HSW13	28.50
	ÜW 50/10 II VSAW- HSW Connex	50	10,000	2x VSAW 1-16/AW36/ CW16/HSW16	29.80
	ÜW 50/16 II VSAW-HSW Connex	50	16,000	2x VSAW 1-16/AW36/ CW19/20/HSW19/20	33.10
	ÜW 50/19 II VSAW-HSW Connex	50	19,000	2x VSAW 1-22/AW50/ CW26/HSW22	66.90
	ÜW 50/26.5 II VSAW-HSW Connex	50	26,500	2x VSAW 1-22/AW50/ CW26/HSW26	72.30
	ÜW 50/36 II VSAW-HSW Connex	50	36,000	2x VSAW 1-22/AW50/ CW32/HSW32	97.30
	ÜW 100/26.5 II VSAW-HSW Connex	100	26,500	2x VSAW 1-32/320/AW50/ CW26/HSW26	132.70
	ÜW 100/40 II VSAW-HSW Connex	100	40,000	2x VSAW 1-32/320/AW50/ CW32/HSW32	151.30

<sup>1</sup>VSAW angle of inclination: max. 25°

# Special accessories in G8

## Product overview

### Content

Unilock connecting link	92
Swivel	93
Clevis connector	94
Concrete pipe lifting sling	95
Clevis turnbuckle	96
S-hook	97
Bale hook	98
Barrel hook	99
High-tensile lifting tong	100
Spreader beams and special components	101





## pewag U Unilock connecting link

### Heat-resistant up to 100 °C.

This universal connecting link in Grade 8 is suitable for a wide range of applications.

The connecting link is easy and quick to assemble by a competent person thanks to the hexagon screw and nut. A full operating manual provides detailed information on the assembly process. The connecting link is manufactured according to EN 1677-1, comes with CE marking and is heat-resistant up to 100 °C. Always ensure that the nut is not overtightened and that the screw is able to rotate.

The special screw, the hexagonal nut and washers are available as a spare parts set. As the screw is a special screw, it must always be replaced by an original part.

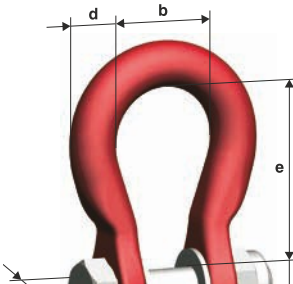

U Unilock connecting link	Code	Load capacity [kg]	e [mm]	b [mm]	d [mm]	s [mm]	a [mm]	M [mm]	Weight [kg/pc.]
	U 5/6	1,120	34	21	9	11	16	7	0.07
	U 7	1,500	49	28	13	16	22	8	0.20
	U 8	2,000	48	28	13	16	22	10	0.22
	U 10	3,150	60	35	16	20	27	12	0.38
	U 13	5,300	72	39	18	24	34	16	0.67
	U 16	8,000	80	47	23	32	44	20	1.21
	U 19/20	12,500	96	56	26	36	52	24	1.97
	U 26	21,200	132	77	33	49	66	30	4.06

# pewag DF Swivel

## 130 °C operating temperature.

This swivel is an excellent choice if you are looking for a special accessory in grade 8 that may be rotated under load and withstands an operating temperature of up to 130 °C.

The product is manufactured according to the pewag factory standard and comes with CE marking, BG approval and a full operating manual.



DF Swivel	Code	Load capacity [kg]	e [mm]	d [mm]	d1 [mm]	d2 [mm]	Weight [kg/pc.]
	DF 5/6 *	1,120	44	22	12	7	0.10
	DF 7/8 *	2,000	60	27	16	8	0.20
	DF 10 *	3,150	74	32	20	10	0.30
	DF 13*	5,300	92	40	25	13	0.60

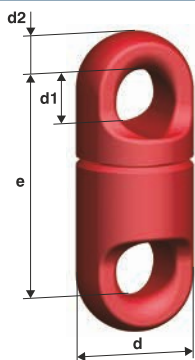

\* Upon request!

# pewag KVS Clevis connector

## A perfect fit.

This clevis connector for grade 8 is designed for the shortening of chain slings and forming of slings that must not tighten and can be mounted without the need for special tools.

The shortening claw has a safety mechanism to prevent the accidental unhooking of the load in grade 8, comes with CE marking and BG approval and is manufactured according to EN 1677-1. A full operating manual outlines all areas of possible use and also gives information on what to watch out for: for instance, the correct load direction of the chain and the correct assessment of the load capacity if combined with grade 10 chains. The clevis system makes this product easy and quick to assemble.

The coupling pin and the retaining pin are available as a KBSW spare parts set.

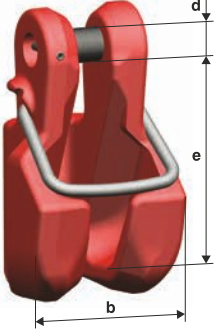

KVS Clevis connector	Code	Load capacity [kg]	e [mm]	b [mm]	d [mm]	Weight [kg/pc.]
	KVS 6	1,120	45	36	7,40	0.27
	KVS 7	1,500	58	44	9	0.50
	KVS 8	2,000	58	44	10	0.50
	KVS 10	3,150	70	55	12,50	0.80
	KVS 13	5,300	90	70	16	1.53

**Safety warnings:**

- Only load the inside chain
- Only use with a safety device
- Ensure that the chain fits neatly and securely

## pewag BRG Concrete pipe lifting sling

### Perfection you can touch.

This three-leg chain sling with self-tightening grips is perfect for lifting and transporting concrete pipes with a diameter between 1,300 and 2,300 mm.

The pipes may have a wall thickness from 60 to 150 mm, with a maximum weight of 2,500 kg.

The concrete pipe lifting sling corresponds to the pewag factory standard and may be used in a three-leg chain sling with an inclination angle of up to 30°. For safety reasons, the grippers must not be used for diagonal pull. The maximum operating temperature is 100 °C.

A full operating manual provides information on all features and areas of application.



BRG Concrete pipe lifting sling	Code	Leg length	Load capacity up to 30°	Up to tube diameter-ø	Weight
		[mm]	[kg]	[mm]	[kg/pc.]
	WIN 7 III AW-BRG 1500	1,500	2,500	1,300	35.40
	WIN 7 III AW-BRG 2000	2,000	2,500	1,800	36.60
	WIN 7 III AW-BRG 1500 Unilock	1,500	2,500	1,300	35.30
	WIN 7 III AW-BRG 2000 Unilock	2,000	2,500	1,800	36.50
Customs lengths are available upon request!					
<b>Universal chain sling with shortening hook</b>					
	WIN 7 III VXKW-BRG 2000	2,000	2,500	1,800	38.50
	WIN 7 III VXKW-BRG 2500	2,500	2,500	2,300	39.70

# pewag KSS Clevis turnbuckle

## Takes robustness to a higher level.

Some jobs need a no-nonsense approach for top results. The KSS clevis turnbuckle has a particularly robust design, with grade 8 clevis couplings that are die-forged and tempered on both sides. By mounting the turnbuckle into the chain strands, the length of the chain can be adjusted precisely, for instance when the load needs to be aligned in a certain way.

The turnbuckle is manufactured according to EN 1677-1 and comes with a full operating manual. It is suitable for straight pull only and may be assembled easily and quickly thanks to its clevis structure, without the need for special tools. For lifting operations, an additional safety chain must be used to prevent accidental opening. One of the great advantages of this product lies in the fact that the coupling pin and the retaining pin are available as a KBS-KSS spare parts set.

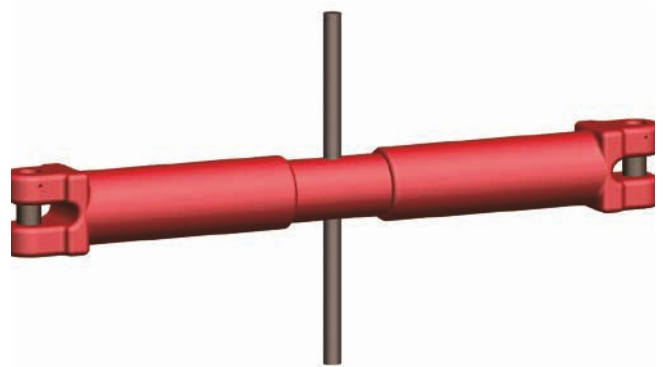

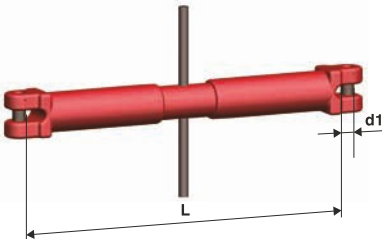
KSS Clevis turnbuckle	Code	Load capacity [kg]	Tension distance [mm]	L min. [mm]	L max. [mm]	d1 [mm]	Weight [kg/pc.]
	KSS 7	1,500	90	230	320	8	2.90
	KSS 8	2,000	120	330	450	10	3.20
	KSS 10	3,150	215	455	670	12	3.90
	KSS 13	5,300	280	515	795	16	6.50
	KSSW 16	10,000	250	530	780	20	10.00



## pewag SM S-hook

### Bent on success.

This S-hook can withstand temperatures of up to 300 °C. It is manufactured according to EN 1677-1 and classified as a grade 8 special accessory. The hook may also be used as an intermediate hook if the „g“ jaw size of the HSW hook is insufficient, or as an intermediate hook with wire rope loops.

Prior to each use, please determine whether the hook may be used without a safety catch. Always observe the load capacities – they do not correspond to grade 10! A full operating manual provides details on usage and application.

This S-hook comes with CE marking. It is suitable for straight pull only and the tip must not be placed under load. An added benefit: Customised designs with a safety catch are available upon request!



SM S-hook	Code	Load capacity [kg]	e [mm]	g [mm]	d [mm]	Weight [kg/pc.]
	SM 5	800	180	42	16	0.60
	SM 7/8	2,000	220	53	23	1.50
	SM 10	3,150	280	58	31	2.90
	SM 13	5,300	400	90	40	8.20
	SM 16	8,000	500	120	50	16.00
	SM 19	11,200	550	130	60	26.00

Custom designs are available upon request.

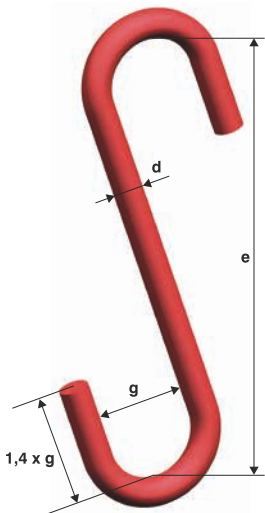

## pewag BA Bale hook

### Concentrated power.

The bale hook is a special accessory in grade 8, suitable for welded or Connex systems. It is ideal for lifting and transporting bales and structural steel wire meshes, is manufactured according to the pewag factory standard and comes with CE marking. A full operating manual provides details on usage and application.

Prior to each use, please verify whether the hook may be used without a safety catch. Also note that this hook is suitable for straight pull only and that the load must not be placed on the tip of the hook. An added bonus – customised designs are available upon request!

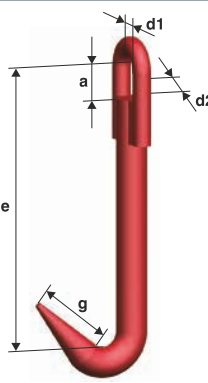

BA Bale and structural steel wire mesh hook	Code	Load capacity [kg]	e [mm]	d1 [mm]	g [mm]	a [mm]	d2 [mm]	Weight [kg/pc.]
	BA 5/6	1,120	160	16	40	24	7	0.34
	BA 7/8	2,000	200	19	50	30	10	0.70
	BA 10	3,150	260	27	65	39	13	1.50

## pewag FA Barrel hook

### Truly uplifting.

Please note that an inclination angle of 30° is the maximum value for this special accessory in grade 8. The hook is perfect for lifting and transporting barrels.

To do this, two hooks are attached to chain, which contracts under load. Moreover, the barrel hook complies with the pewag factory standard and comes with a full operating manual.



FA Barrel hook	Code	Load capacity [kg]	e [mm]	d [mm]	d1 [mm]	b [mm]	Weight [kg/pc.]
	FA 5/6	500	90	40	17	70	0.80

Length = Length of sling L as with sling type II AW-S.

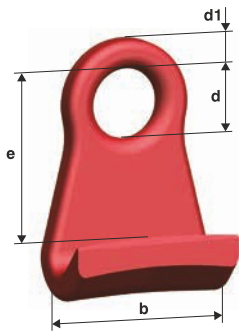

# pewag HZ High-tensile lifting tong

## Benefits that go further.

The tips of these high-tensile lifting tongs in grade 8 are reinforced, making the lifting of short steel bars easier than ever. Naturally the tongs comply with the pewag works standard and come with a full operating manual.

Always observe the load capacities - they do not correspond to grade 10! Customised designs are available upon request, making these tongs a truly superior choice.

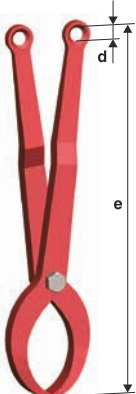

HZ High-tensile lifting tong	Code	Load capacity [kg]	Range [mm]	e [mm]	d [mm]	Weight [kg/pc.]	Required chain sling
	HZ 0.125	125	100 – 200	310	15	2.43	WIN 5 II AW-CW 310
	HZ 0.25	250	130 – 300	466	20	4.77	WIN 6 II AW-CW 410
	HZ 0.5	500	160 – 400	629	28	12.00	WIN 7 II AW-CW 570
	HZ 1	1,000	215 – 500	808	30	24.00	WIN 8 II AW-CW 730
	HZ 2	2,000	250 – 600	959	30	41.00	WIN 8 II AW-CW 830

# pewag Spreader beams and special components

## Spreader beams and special components.

The spreader beam is available with two fixed or adjustable hooks.  
The hook distance is fixed or adjustable.

Other lengths and load capacities are available upon request.

Figure 1 shows a spreader beam with two fixed hooks and fixed hook distance.

Figure 2 shows a spreader beam with two fixed hooks and adjustable hook distance.

Figure 3 – Spreader beams and special components with adjusted load capacities / working widths / hook configurations / lifting options / designs are available upon request.

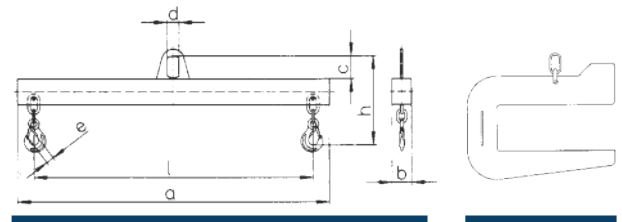

Figure 1

Figure 3

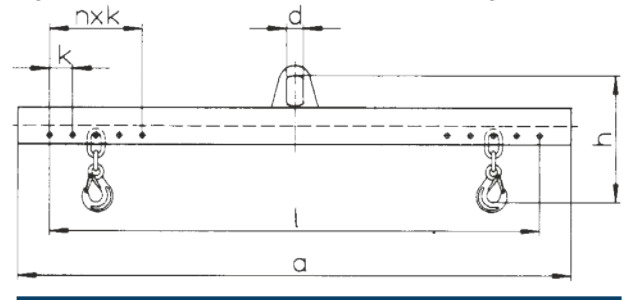

Figure 2

Load capacity [kg]	a [mm]	b [mm]	h [mm]	c [mm]	d [mm]	e [mm]	Hook distance fixed l [mm]	Weight approx. [kg]	Hook distance adjustable l max. [mm]	n x k	Weight approx. [kg]
500	1,080	45	380	100	40	22	1,000	16	1,000	3 x 150	20.00
500	3,100	50	380	130	40	22	3,000	60	3,000	4 x 250	70.00
500	5,200	55	420	130	40	22	5,000	140	5,000	6 x 250	160.00
1,000	1,080	55	380	130	50	22	1,000	20	1,000	3 x 150	25.00
1,000	3,100	65	420	130	50	22	3,000	90	3,000	4 x 250	100.00
1,000	5,200	70	500	130	50	22	5,000	180	5,000	6 x 250	200.00
3,000	1,080	80	500	185	80	29	1,000	60	1,000	3 x 150	80.00
3,000	2,100	100	550	185	80	29	2,000	90	2,000	4 x 150	120.00
3,000	3,100	100	550	185	80	29	3,000	200	3,000	4 x 250	250.00
3,000	5,200	120	600	185	80	29	5,000	400	5,000	6 x 250	500.00
3,000	8,300	150	650	185	80	29	8,000	600	8,000	6 x 250	800.00
5,000	1,080	150	600	240	100	35	1,000	100	1,000	3 x 150	130.00
5,000	2,100	170	650	240	100	35	2,000	200	2,000	4 x 150	250.00
5,000	3,100	200	700	240	100	35	3,000	300	3,000	4 x 250	400.00
5,000	5,200	250	750	240	100	35	5,000	600	5,000	6 x 250	800.00
5,000	8,300	250	750	240	100	35	8,000	1,200	8,000	6 x 250	1,500.00
10,000	1,080	250	700	330	140	43	1,000	120	1,000	3 x 150	150.00
10,000	2,100	250	750	330	140	43	2,000	250	2,000	4 x 150	300.00
10,000	3,100	300	800	330	140	43	3,000	500	3,000	4 x 250	700.00
10,000	5,200	300	900	330	140	43	5,000	900	5,000	6 x 250	1,300.00
10,000	8,300	300	1,000	330	140	43	8,000	1,500	8,000	6 x 250	2,000.00

Other lengths and load capacities are available upon request.

# Spare parts

## Product overview

### Content

Clevis load pins	104
Safety catch sets	105
Bolts + safety bushes	106
Safety catch sets	107
Bolt + nut + washer	107
Bolt + nut + split pin, Trigger sets	108
Tag set for lifting	109



[dlhonline.co.uk](http://dlhonline.co.uk)

0161 223 1990



# pewag<sup>®</sup> KBSW Clevis load pin

## Easily identified.

The KBSW clevis load pin comes with a black corropro coating and corresponds to EN 1677-1, with a higher load capacity. It serves as a standard clevis load pin and is stamped with its grade „10“ and the manufacturer logo „PWW“ and is suitable as a replacement load pin for pewag clevis parts. It is easy to operate, with an outstanding safety factor. Please see Table 2 for a list of parts that require special clevis load pins.



KBSW Clevis load pins standard	Code	L [mm]	d [mm]	L1 [mm]	d1 [mm]	Weight [kg/pc.]
	KBSW 5/6	16.50	7.40	16.00	2.50	0.006
	KBSW 7	23.00	9.00	22.00	3.00	0.01
	KBSW 8	23.00	10.00	22.00	3.00	0.01
	KBSW 10	29.50	12.50	28.00	3.50	0.03
	KBSW 13	37.00	16.00	36.00	4.00	0.06
	KBSW 16	52.00	20.00	40.00	4.50	0.10
	KBSW 19/20	73.00	24.00	50.00	5.00	0.20
	KBSW 22	71.00	27.00	55.00	5.00	0.32
	KBSW 26	86.00	33.00	70.00	5.00	0.58

KBS-KLH-KSS Clevis load pins special	Code	d x L [mm]	d1 x L1 [mm]	For accessory part
	KBS-KSS 7	8 x 22.5	3 x 22	KSS 7
	KBS-KSS 8	10 x 27.2	3 x 26	KSS 8
	KBS-KSS 10	12 x 32.2	4 x 32	KSS 10
	KBS-KSS 13	16 x 45.7	4 x 40	KSS 13



## pewag SFGW Safety catch sets

### Good at their job.

These SFGW safety catch sets with die-forged and electro-galvanised safety catch and a spring from rust-proof spring steel are all about safety and security.

They are suitable for pewag winner accessories. Please refer to the tables to determine which set goes with which hook.

The safety catch sets are in a league of their own – even the tiniest pewag parts offer outstanding quality!

SFGW Forged safety catch set for HSW, KHSW, WS, EHS, WSBW, HS	Code	For accessory part
	SFGW 5/6	HSW 5/6, KHSW 5/6
	SFGW 7/8	HSW 7/8, KHSW 7, KHSW 8, WS 7/8, EHS 7/8, WSBW 7/8
	SFGW 10	HSW 10, KHSW 10, WS 10, EHS 10, WSBW 10
	SFGW 13	HSW 13, KHSW 13, WS 13, EHS 13, WSBW 13
	SFGW 16	HSW 16, KHSW 16
	SFGW 19/20	HSW 19/20, KHSW 19/20
	SFGW 22	HSW 22, KHSW 22
	SFGW 26-32	HSW 26, HSW 32, HS 32

SFGW-G Forged safety catch set for GKHSW	Code	For accessory part
	SFGW-G 8	GKHSW 8
	SFGW-G 10	GKHSW 10

SFGW-B Forged safety catch set for BKHSW	Code	For accessory part
	SFGW-B 8	BKHSW 8
	SFGW-B 10	BKHSW 10

SFGW-A Forged safety catch set for AWHW, UKN	Code	For accessory part
	SFGW-A1	AWHW 1.3
	SFGW-A3	AWHW 3.8
	SFGW-A6	AWHW 6.3, AWHW 10

SFGW-W Forged safety catch set for WS	Code	For accessory part
	SFGW-W16	WS 16

## pewag CBHW Bolts + safety bush

### Quality assurance.

The spare parts set for CW Connex connecting links and CARW round sling connecting links know no compromises when it comes to safety. For this reason, we recommend replacing each safety set after it has been assembled/disassembled three times – quality assured! The bolt comes with a black corropro coating and looks rather unremarkable - however, its modest exterior hides an unsurpassed level of know-how and expertise!



CBHW bolts + safety bush for CW, CARW	Code	For accessory part
	CBHW 5 G10	CW 5
	CBHW 6 G10	CW 6
	CBHW 7 G10	CW 7
	CBHW 8 G10	CW 8, CARW 8
	CBHW 10 G10	CW 10, CARW 10
	CBHW 13 G10	CW 13, CARW 13
	CBHW 16 G10	CW 16, CARW 16
	CBHW 19/20 G10	CW 19/20
	CBHW 22 G10	CW 22, CARW 22
	CBHW 26 G10	CW 26
	CBHW 32 G10	CW 32

## pewag CLBHW Bolts + safety bush

### Optimal with Connex.

The CLBHW bolt and safety bush is the replacement part for CLW with non-removable bolts and ideal partner for the Connex system!



CLBHW bolts + safety bushes for CLW	Code	For accessory part
	CLBHW 7 G10	CLW 7
	CLBHW 10 G10	CLW 10
	CLBHW 13 G10	CLW 13
	CLBHW 16 G10	CLW 16

## pewag PSGW Safety catches

### Optimal safety.

When it comes to safety catches, the name says it all. They are regarded ideal replacement parts for PSW and KPSW grab hooks with safety catches. The spring is particularly user-friendly and made from rust-proof spring steel. We recommend protecting the nut from accidental release by using a prick-punch or glue.



PSGW Safety catches for PSW	Code	For accessory part
	PSGW 7/8 G10	PSW 7/8 + KPSW 7 + KPSW 8
	PSGW 10 G10	PSW 10 + KPSW 10
	PSGW 13 G10	PSW 13 + KPSW 13
	PSGW 16 G10	PSW 16 + KPSW 16

## pewag UBMS Bolt + washer + nut

### Full house.

This comprehensive set contains all the spare parts needed for U Unilock. The screws for these components are special screws – please note that standard screws must not be used. The screw, nut and washers are manufactured to the highest standards, in true pewag style.



UBMS Bolt + washer + nut for U	Code	For accessory part
	UBMS 5/6	U 5/6
	UBMS 7	U 7
	UBMS 8	U 8
	UBMS 10	U 10
	UBMS 13	U 13
	UBMS 16	U 16
	UBMS 19/20	U 19/20
	UBMS 26	U 26

## pewag KBMSW Bolt + nut + split pin

### Good things come in threes.

Clevis shackles need an overhaul from time to time in order to maintain the pewag quality standards that we are committed to and also recommend to our customers. Replacing the shackles is easy: The KBMSW screw, nut and split pin are the ideal spare parts combination for KSCHW clevis shackles.



KBMSW Bolt + nut + split pin for KSCHW	Code	For accessory part
	KBMSW 7/8 G10	KSCHW 7, KSCHW 8
	KBMSW 10 G10	KSCHW 10
	KBMSW 13 G10	KSCHW 13

## pewag VLHW Trigger sets

### Safety you can rely on.

Trigger sets for LHW, KLHW and WLH(B)W safety hooks consist of a high-strength safety lever, a spring made from rust-proof spring steel and a retaining pin. The sets come with auxiliary material to facilitate assembly as well as detailed assembly instructions to make sure that your safety standards leave nothing to be desired.



VLHW Trigger sets for LHW, KLHW, WLH(B)W	Code	For accessory part
	VLHW 5/6* G10	LHW 5/6, KLHW 5/6, WLH(B)W 6
	VLHW 7/8* G10	LHW 7/8, KLHW 7, KLHW 8, WLH(B)W 7/8
	VLHW 10* G10	LHW 10, KLHW 10, WLH (B)W 10
	VLHW 13* G10	LHW 13, KLHW 13, WLH(B)W 13
	VLHW 16* G10	LHW 16, KLHW 16, WLH(B)W 16
	VLHW 19/20/22/26 G10	LHW 19/20, LHW 22, KLHW 19/20, KLHW 22, KLHW 26

Please specify the correct hook design in your order – also see sample order form

## pewag IDW + ID Tag sets WIN 400 and 200 for lifting

### Customised for you.

This is the spare part set for pewag winner 400 and 200 lifting chains. After all, the advantage of being able to customise your tags with names, logos etc. is worth protecting!

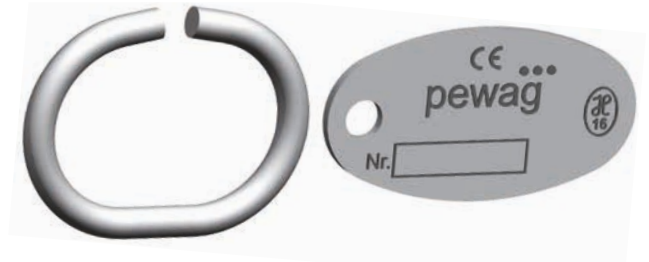

IDW-Set WIN 400



IDW-Set WIN 200



ID-tag set neutral

IDW + ID Tag sets for lifting	Code	For lifting chains	Consisting of
	IDW-Set WIN 400	I- and multi-leg slings	tag for WIN 400 + open link 8 x 62 + safety instruction
	IDW-Set WIN 200	I- and multi-leg slings	tag for WIN 200 + open link 8 x 62 + safety instruction
	ID-Tag set neutral	I- and multi-leg slings	tag neutral + cable with quick release fastener + safety information

# User information

## for lifting in G10

### Content

User information on pewag lifting accessories 112-115



[dlhonline.co.uk](http://dlhonline.co.uk)

0161 223 1990



# User information

**General information and safety-specific information on usage, storage, inspection and maintenance of pewag lifting accessories.**

## General information

pewag prides itself on its versatile and multi-faceted quality products that suit a wide range of applications. Different construction, loading and lashing methods for general lifting applications do not pose a particular challenge for our universally applicable lifting accessories as they were manufactured with precisely these different demands in mind. All information on design and load capacities in the catalogues (Uniform Load Method) take this range into account. There is also an alternative method in existence for rating the product load capacity, for which the specific application scenario of the chain and all operating conditions must be known. In such a case, please contact the pewag Technical Service team, as the information contained in the catalogues does not apply to such processes.

### Responsibility is key

If the pewag lifting accessories are used correctly and by competent persons, they have a long lifespan and provide the highest possible safety standards. Material and personal damage can be avoided by reading this user information carefully and handling all lifting processes in a responsible, provident manner.

## Changes to the condition as delivered

We urgently recommend using only the original parts that are included in the scope of delivery with pewag lifting chains (bolts, safety pins, screws etc.) Modifying the original condition of the lifting accessories by bending, grinding, removal of parts, welding, drilling, stamping etc. means exposing yourself and others to unnecessary danger. In such a case, safety can no longer be guaranteed and usage becomes dangerous. Risk factors and conditions include heating the chains to a temperature of more than 380 °C (pewag winner 400) and removing safety parts such as safety pins, safety catches etc. Do not apply any surface coatings to pewag chain slings, i.e. do not subject them to hot galvanizing or electrogalvanizing.

If any surface treatments are required, please make sure to double-check with the pewag service department first. Dipping or removing a coating with chemicals are potentially dangerous processes that may give rise to hazards. We urgently recommend customers to check with the pewag technical team first.

## Restrictions of use

**For hazardous or dangerous conditions, please refer to the table on page 20.**

### Temperature effects

The table on page 20 lists the load reduction values in case of extreme temperatures. These apply until the chain and/or the lifting accessories have reached room temperature. pewag lifting accessories must on no account be used outside the indicated temperature range. If this has been the case, the chains must be removed from service.

### Effects of acids, caustics and chemicals

pewag lifting accessories must not be used in acids or caustic solutions or be exposed to their vapours. Please be aware of this requirement at all times as certain production processes release acids and/or vapours! If the use of pewag lifting accessories with highly concentrated chemicals in combination with high temperatures cannot be avoided, please make sure to obtain the express approval of such usage by a pewag expert.

### Hazardous conditions

The working load limits in this catalogue have been determined on the basis that the product is not being used in hazardous conditions. Hazardous conditions are present when lifting accessories are used offshore or for the lifting of persons or potentially dangerous goods such as liquid metal, corrosive or caustic substances or nuclear material. If the chain sling is to be used for such purposes, the extent of the risk is to be assessed by an expert, the load capacity must be adjusted accordingly and incorrect usage in hazardous conditions must be avoided at all cost. As a rule, usage in hazardous conditions should be avoided.

### Prevention is better than cure!

Before using any lifting accessory, several inspections must be performed:

- Does the lifting chain correspond to the order?
- Has the inspection certificate or certificate of conformity been supplied?
- Do the markings and load capacities stated on the chain sling correspond to the information given on the inspection certificate or certificate of conformity?
- Have all the particularities of the chain sling been entered into a register of lifting equipment, if required?
- Has the operating manual outlining the correct use of the chain sling been supplied and read and understood by all personnel?

Please check the lifting accessories for visible signs of damage or wear prior to each use. In case of any doubt or damage, do not use the chain slings and have them inspected by a competent person.

Inspections by a competent person must be performed in accordance with national legislation, but at least once every 12 months. If the chain sling is frequently used at its full load capacity, more frequent inspections are required!



Please note that the chain sling must also be inspected after unusual events, for instance uncontrolled exposure to heat.

We recommend subjecting the chain sling to a load capacity test with 2 times the load capacity every two years, followed by a visual inspection, or another type of crack test.

**Visual inspection criteria**

If at least once of the criteria listed below manifests itself during the visual inspection, all parts must be removed from service:

- Breakage of a component
- Illegible or missing marking of the chain sling (i.e. information on identification data and/or load capacity)
- Deformation of suspension or sling parts or the chain itself
- Elongation of the chain resulting in  $t > 1.05 \text{ tn}$
- Wear as determined by the mean value of two measurements of diameters  $d_1$  and  $d_2$  carried out at a right angle as shown. The chain must be removed from service life if:

$$dm = \frac{d_1 + d_2}{2} \leq 0.9 \text{ dn}$$

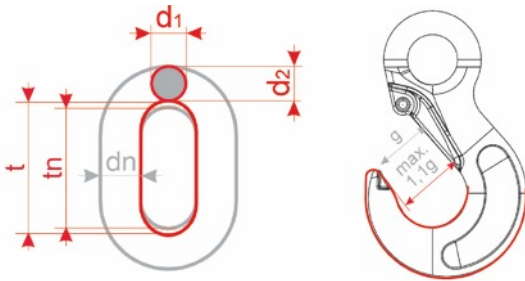

- Visible damage such as cuts, notches, grooves, surface cracks, discolouration due to excessive heat exposure, signs of subsequent welding, bent or twisted links or other flaws
- Obvious wear or chemical removal of material if the admissible dimensional changes as outlined in the table supplied has been exceeded, e.g. pitting corrosion
- Cracks and cross-cracks that are visible to the naked eye
- Missing or non-functional safety device as well as signs of widening or twisting of hooks, i.e. noticeable enlargement of the opening or other forms of deformation. The critical point is reached when the enlargement of the opening exceeds 10 % of the nominal value or if the safety catch is open, as this indicates that the hook is overloaded.

**Correct maintenance**

Please note that all maintenance activities of pewag lifting accessories must be handled by competent persons to minimise the risk of improper use.

**Precise documentation**

All inspections and their results must be recorded and these records be kept throughout the service life of the chain slings. Precise records of this sort constitute the best basis for effective maintenance.

**Clean storage**

pewag lifting chains must always be stored in a clean and dried condition and protected against corrosion, i.e. slightly lubricated.

**Maximal approved dimensional change:**

Designation	Dimensions	Admissible deviation
chain	dm	-10 %
	t	+5 %
links	d	-10 %
	t	+10 %
hooks *	e	+5 %
	$d_2$ and h	-10 %
	g	+10 %
	a	-10 %
CW, CARW, CLW	halves loose	no changing admissible
	e	+5 %
	c	-10 %
BWW, GHW	e	+5 %
	d	-15 %
	$d_1$	+5 %
	angle change	$\leq 3^\circ$
SCHW, GSCHW, U	bolt loose	no changing admissible
	e	+5 %
	$d, d_1, d_2$ and M	-10 %
SM	e	+5 %
	g	+10 %
	d	-10 %
BA	$d_2$	-10 %
FA	$d_1$	-5 %
Clevis bolts Connex bolts	d	-10 %
	$d_2$	-10 %
LHW, KLHW, WLH(B)W	h	-10 %
	opening of hook	2x s max.

\* HSW, FW, PW, KHSW, WSBW, GKHSW, SH, KSCHW, KCHW, KFW, KPW, KVS, XKW, KOW, KRW, WS, DFW, WSBW

## Correct use of chain slings

### The right angle of inclination

To ensure safe handling, the slinging points and chain sling types must be selected in such a way that the angles of inclination of all chain strands (legs) lie within the data given on the load capacity tag. Preferably, all angles of inclination should be the same. Avoid angles of inclination of less than 15° because of the high risk of load instability. Never use chain slings with the angle of inclination exceeding 60°!

### Edge-loading – know your limits

The maximum load capacity of pewag chain slings assumes that the individual chain legs are pulled straight under load, i.e. that they do not run over edges. However, if edge-loading is unavoidable, load protection (packing) should be used to avoid damage (see illustration):

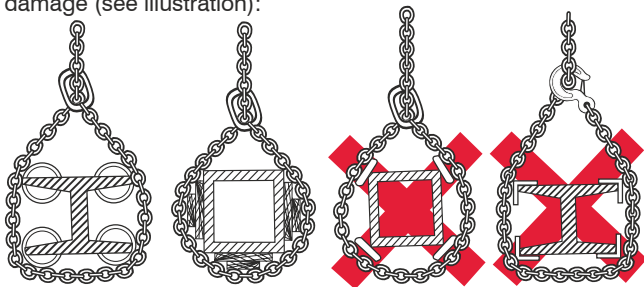

If chains are guided over edges without proper protection, their load capacity is significantly reduced and safe usage can no longer be guaranteed. See the table on page 20 for the corresponding load factors. Where chain have to be looped around beams or other round-shaped loads, the diameter should be at least twice or 3 times the chain pitch. For smaller diameters, the load capacity of the chains must be reduced by 50 %.

### Impact-/shock-loading

For the load capacities of pewag lifting chains to apply, it is assumed that the individual chain strands are not subjected to impact- or shock-loading. In cases of possible impact/shock, the load factors on page 20 apply.

### Classification of impacts

- Slight impact may result from accelerated lifting or lowering operations
- Medium impact may result from the chain slipping while adjusting itself to the shape of the load
- Strong impact results for instance from the load falling into the unloaded chain

### Vibrations

If they are used correctly, pewag lifting chains and accessories withstand high load cycles, with a standard rating of 20,000 load cycles. In case of high dynamic loads, there is a risk of the chain or components getting damaged. The employer's liability insurance association Metall Nord Süd recommends reducing stress at WLL by using a larger nominal thickness/size in such a case.

### Symmetrical loading

For the load capacities of pewag lifting chains to apply, it is assumed that the individual chain strands are placed under load symmetrically. When the load is lifted, this results in equal angles of inclination and the individual strands are symmetrical to each other.

The load may be considered symmetrical when all of the following conditions apply:

- The load is less than 80 % of the indicated load capacity
- The angles of inclination of all chain strands are not lower than 15° and are very similar (i.e. only differ by a maximum of 15°).
- For three- and four-stranded lifting chains, it must be ensured that the corresponding plan angles are within 15° of each other.

### Be careful!

If not all of these parameters are complied with, the load cannot be considered symmetrical and the classification of the lifting operation must be left to an expert. In case of doubt, only one chain strand (leg) should be considered as load-bearing. For the corresponding load capacity values, please refer to the load capacity table on page 18 and 19 to determine the precise load capacity.

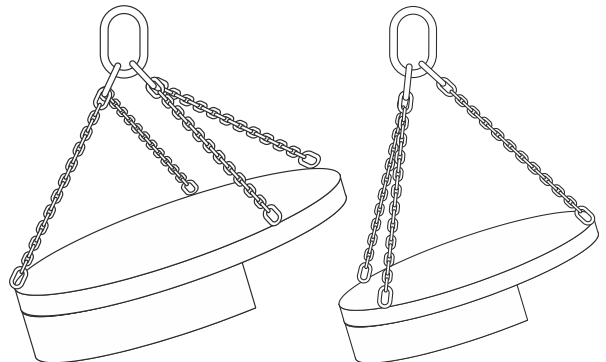

The main part of the load is carried by just one leg.

The main part of the load is carried by two legs.

### Wrongful use defeats the purpose

pewag lifting chains offer perfect quality standards if they are used according to their intended purpose.

In cases where not all individual legs are used simultaneously or where several lifting chains are used at the same time, different load capacities apply as outlined in the tables on pages 18 and 19. In case of doubt regarding the intended purpose, the load capacity as indicated on the tag must be amended in accordance with the following table:

Type of sling chain	Number of individual strands used	Use factor in relation to the load capacity given on the tag
two-stranded (II-leg)	1	1/2
three- and four-stranded (III/IV-leg)	2	2/3
three- and four-stranded (III/IV-leg)	1	1/3
2 x single-stranded (single leg)	2	1.4 up to 45°
2 x two-stranded (II-leg)	3 or 4	1.5 from 45° – 60°

### Precautions

- Hang any individual strands (leg) that you do not use back into the master link to prevent hazards caused by freely swinging chains or unintended hooking.
- Before using several chain slings at the same time, make sure that the crane hook is big enough for all the master rings. Make sure that the master rings cannot fall out of the hook during lifting.
- Angles of inclination of more than 45° must be avoided.
- Use only chain slings of the same nominal thickness and grade at the same time.

## Additional detailed information

Never tip-load the hook!

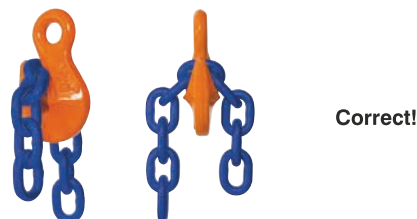
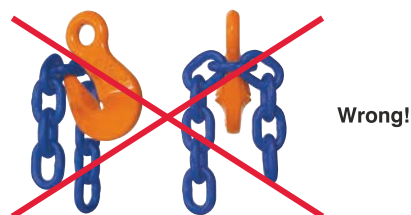

Detailed original operating manuals for individual products are available for download at [www.pewag.com](http://www.pewag.com). Our manuals are subject to a continuous improvement process to ensure that they are always up to date. For this reason, always refer to the latest version of a manual.

## Contact Us

# DALE

Lifting and Handling Specialists  
2 Kelbrook Road, off Stainburn Road  
Parkhouse Street Industrial Estate

Manchester M11 2QA

t. 0161 223 1990

f. 0161 223 6767

e. [info@dale-lifting.co.uk](mailto:info@dale-lifting.co.uk)

w. [www.dlhonline.co.uk](http://www.dlhonline.co.uk)



[dlhonline.co.uk](http://dlhonline.co.uk)

0161 223 1990