

New for 2019

Tiger Corrosion Resistant Chain Block

Model No. SS20



Heavy duty, operator-friendly latch kit



Patented Quad Cam Pawl System



Main Features

- Suitable for use in multi-immersion applications
- DNV GL Verification tested according to NORSOK R-002
- Range from 500kg – 20000kg
- Patented Quad Cam Pawl System
- Phosphor Bronze Bearings
- Tested and certified for “fleeting”, “drifting” and “cross-hauling” applications up to 45° from the vertical without deration
- Guaranteed 2% light load protection
- Fully Corrosion protected body and components to ensure reliable long-term use
- Over 1500 hours protection to ASTM B117 conditions
- Corrosion protected load and hand chain
- Double cover protection for brake chamber
- Marine chain bags available on request
- Available with slipping clutch overload protection



The SS20 is manufactured from the highest quality steel materials precisely machined in our own factory, offering a lightweight, compact and rugged construction, producing an exceptionally strong product resistant to impact damage. The especially low headroom allows for easy installation in the most restricted environments. The unique design features listed below give it significant safety advantages over standard chain blocks and make the SS20 chain block the ideal tool for saltwater use with low maintenance and servicing costs.

These units meet and exceed all the requirements within BS EN 13157: 2004+A1:2009, ANSI/ASME B30.16, AS1418.2* and SANS 1594. Tiger Hoists fitted with overload limiters comply fully with NORSOK R-002.

* When fitted with load bearing swivel hooks, Tiger hoists comply fully with AS 1418.2

Key design features such as our patented brake pawls and deep pocket design hand wheel along with the full and comprehensive testing regime we have submitted our SS20 hoist to provide the evidence that allows us to state that these units can be safely used for "fleeting", "drifting" and "cross-hauling" applications up to 45° from the vertical without deration.

With over 50 years of professional manufacturing experience, Tiger's commitment to innovation and customer satisfaction mean we will continue to develop and improve our products by communicating and working with our customers. The SS20 range of chain blocks incorporates our latest developments and enhancements.

Environmental Testing and Multi-Immersion:

After successfully completing a series of third party verification and testing programmes to beyond established international standards, our latest being a multi-immersion programme of tests over 54 days independently carried out and verified at ORE Catapult in the UK (a leading technology innovation and research centre for offshore renewable energy), we can state that the SS20 range of chain blocks is suitable for use in multi-immersion applications providing the timescales, pre-use testing, maintenance and service requirements as detailed in Tiger document Multi-Immersion Instruction Manual are strictly followed.



We used a subsea dock including a replica seabed



Saltwater was pumped in from the Blyth Estuary (North Sea)

This takes our testing far beyond the requirements of ASTM B117 environmental conditions with the SS20 range having over 1300 hours continuous exposure to an industry generated test programme in a real life offshore and subsea environment. We have also carried out intensive internal testing on components to ensure we achieved over 1500 hours protection to ASTM B117 conditions. This ensures the performance of the SS20 has been fully challenged in natural environments similar to the conditions it will be exposed to.



Certification:

Each unit comes fully certified with a test certificate or an EC Declaration of Conformity stating compliance with the essential health and safety requirements of the Machinery Directive 2006/42/EC. This document clearly states the proof test at 1.5 times the rated capacity and the light load test of 2% of the rated capacity, which exceeds the requirements of the current applicable standard.



Brake Efficiency:

Tiger SS20 lever hoists utilise an 8 point multi-start thread pinion shaft which doubles the lead distance compared with typical 4 point threaded shafts, increasing the brake efficiency by 100%. The rotational engagement of the brake works with the direction of the load sheave creating highly efficient braking ratios. With our fine manufacturing tolerances between the pinion shaft thread and critical brake components we have engineered out a known failure mode where contamination to the threads can lead to brake failure or slippage.

Patent Protected Quad Cam Brake Pawl System:

Our patented Quad Cam Pawl System guarantees permanent engagement of at least one of the two reciprocating cam pawls fitted to the SS20, ensuring the pawl only just clears the ratchet wheel, with the minimum of clearance as required under BS 4898:1973. But most importantly, in the unlikely event of a pawl spring failure, this design will ensure the brake is still fully functional and the load is sustained without damage to the mechanism.



Forgings:

Recessed hook yoke forgings offer full protection to the load chain anchor bolts on all our bottom hooks. Precise tolerances in the bottom hook yokes means foreign objects are restricted from entering the load sheave area.

Bonded Marine Friction Discs

The bonded marine friction discs are free of asbestos and have been developed and designed for subsea use creating a highly efficient, reliable braking surface for use in the most extreme conditions. These models are supplied with a grooved friction disc system which assist with dispersing salt water from between key surfaces therefore eliminating failure through aquaplaning (where a layer of water builds between brake surfaces leading to a loss of friction).





Chain End Stops:

Will hold a load of at least 2.5 times the rated capacity when supporting the full load without restraint from other components e.g. brake or gearing as required in many international standards. This prevents accidents, by acting as a stop when the lift length of the load chain is exceeded when lowered.

Phosphor Bronze Bearings:

The Tin content increases the corrosion resistance and strength of the alloy, the Phosphorus increases the wear resistance and stiffness of the alloy. Needle Bearings have been proven to be unstable and unsuitable for offshore and marine environments.

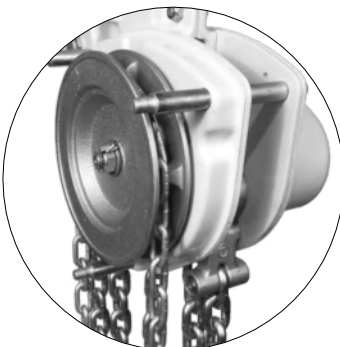

Double Cover Protection:

Both the hand chain wheel cover and the ratchet brake cover are designed to offer protection to the brake chamber in the harshest environments from foreign objects.

Hooks:

Our hooks incorporate our latest Patent Pending "EZ Check" feature which allows operators and inspection engineers to easily check to see if the hoist has been previously overloaded or shock loaded by simply measuring between the triangle of pop marks.

Our drop forged and heat treated alloy hooks are furnished with heavy duty spring latch kits that fully engage into the recessed nose of the hook safeguarding the load when side loading of the latch occurs and offering maximum load security. The swivel hooks are attached to the yoke using high grade nuts & bolts allowing for complete inspection during any statutory inspection or written scheme maintenance.





The entire hook fitting has been protected using OCP or stainless steel fixtures and fittings. Our latest latches incorporate a new wing design making them easier to operate in the operation area (e.g. wet gloved hands for offshore or subsea use).

Available with hooks that swivel under the full working load limit, to meet relevant standards i.e. AS 1418.2. Also available with spark resistant hooks.

Chain Carriers:

All our SS20 chain blocks are available with chain bags on request to fit the exact amount of chain specified. Designed to carry and hold the exact length of load chain required for the operation. Incorporating a stainless steel frame work and heavy duty PVC flexible bag reinforced by webbing with eyelet drain holes for an easy transfer through the splash zone. These chain bags prevent loose chain from getting snagged during lifting or lowering operations and protect any loose chain during transit to and from the operational site.



Protection and Finish:

SS20 hoists have a distinctive body and hooks to clearly define use in a marine environment.

Internal components are corrosion protected using our own unique formulation giving unprecedented long-term levels of corrosion protection. Stainless steel fittings are used throughout the hoist. These ensure the initial capital outlay of purchasing the SS20 is protected by allowing the statutory inspections and re-certifications to be easier and also help with the overall aesthetics of the hoist being maintained in an "as new" condition.

We have carried out intensive internal testing on components to ensure we achieved over 1500 hours protection to ASTM B117 conditions.

SS20 hoists are completed with a two-stage finish combining electroplating as a base layer and then finished with a very hard wearing sand texture powder coating paint which offers excellent corrosion protection and high impact protection. The lessons learned from previous models have allowed us to once again raise the bar with the SS20 in giving longer life corrosion protection ideally suited for multi-immersion applications.



Multi Fall Load Sheave Bearings:

We have incorporated DU® self-lubricating metal polymer bearings into our multi chain fall load sheaves. Their success lies in the unique composite bearing structure comprised of a steel backing for mechanical strength and a porous sintered bronze interlayer impregnated with PTFE and lead for high wear resistance and extremely low friction properties. This makes them ideally suited to hoists used subsea. They provide improved energy efficiency due to low friction of PTFE-enriched overlay and have an extended service life with a strong wear-resistant bronze layer. There is zero maintenance as self-lubricating bearings can operate perfectly dry but have greater reliability with lubricant to avoid potential shaft/bearing seizure under boundary conditions.



Combination Trolley and Block

The top hook can be replaced by a competent person so the SS20 can be directly fitted to our beam trolley range of the equivalent capacity achieving the lowest possible headroom.

Tiger ROV Chain Block

The Tiger ROV compatible chain block is available in various different interface options all in accordance with BS ISO 13628-8:2002 ROV Interfaces on Subsea production systems. Tested and finished in accordance with Annexes B & K of BS ISO 13628-1:2005:

1. Hydraulic Hot Stab connection dual port type A and B
2. Rotary Torque Receptacle Classes 1,2 & 3
3. D Handle, T-bar or Fishtail Direct Drive manual connection
4. QD Direct Drive Couplings

Available as a 3.0 tonne (single fall of load chain), 10 tonne (3 falls), 15 tonne (5 falls) and 20 tonne single head (6 falls) capacity chain blocks, chained up to project specific heights of lift (H.O.L) that can be pre-set to meet the exact starting point required within the rigging drawings. Please see our separate technical sheet for more details.



Overload Protection:

The SS20 chain block can be fitted with a slipping clutch overload mechanism to protect it from overload. When the load limit is exceeded, the clutch in the chain wheel will slip, allowing the handle to be operated whilst not engaging the gear box. This prevents further lifting of the load, though lowering is still possible. The SS20 with overload protection is DNV GL Verification tested according to NORSOK R-002.

Safety Brake:

The highly efficient and fully corrosion protected brake system works instantly when the operation is stopped and securely holds the load. Loads are lowered under perfect control, allowing for precise operations. The SS20 easily passes the "brake lock out test" as per BS 3243:1990 with a 2% load of the rated capacity.



Light Load Protection:

The SS20 brake system guarantees a light load protection at 2% of the rated capacity.

Load Chains:

Tiger only use the highest quality alloy, calibrated load chains in Grade T or VH conforming to EN818-7 and ISO 16872. These chains have been protected using OCP protection without any loss of mechanical performance. The SS20 comes as 3.0mtr HOL as standard but can be chained up to whatever length is required. Stainless steel load chain available on request for certain capacities.

High Performance Premium Grease:

We use new technology, wide temperature range, high performance premium grease. It contains no heavy metals or other harmful or environmentally undesirable additives such as sulphur, phosphorus, chlorine, zinc, phenols, antimony, barium or lead. This selection achieves the correct viscosity to prevent the grease migrating from the area of application. Even when mixed with 50% high water absorption we achieve excellent adhesion and no sign of breakdown after 100,000 strokes and remains unchanged with no slump or breakdown unlike other "premium" greases. Load carrying ability, mechanical stability, corrosion protection, water resistance and increased operating temperature ranges are all improved by the using only the very best lubricant.

Lifting at Angles:

The SS20 range of chain blocks fitted with the patented protected Quad Cam Brake System has undergone a full and comprehensive testing regime that was drawn up by industry specialists and Tiger's mechanical engineers to provide evidence that these units can be safely used for "fleeting", "drifting" and "cross-hauling" applications up to 45° from the vertical without deration. **Note:** All such operations should be carried out in accordance with manufacturer's instructions and fully risk assessed by a competent person.

With a conventional twin pawl brake mechanism (teardrop design) failure can occur if the pawl spring erodes, fractures or a shock load bounces the pawls out of the ratchet gear. Without the spring these systems rely on gravity keeping the pawls engaged and are flawed when the hoist is used at angles away from the vertical.

Hand Wheel:

For chain blocks to be used up to an angle of 45 degrees, it's

critical that the hand chain leaves and enters the hand wheel without twisting, snagging or jamming. Thanks to our specially designed deep-profile chain block hand wheel this is achievable as it helps to seat the chain no matter what angle or direction of pull.

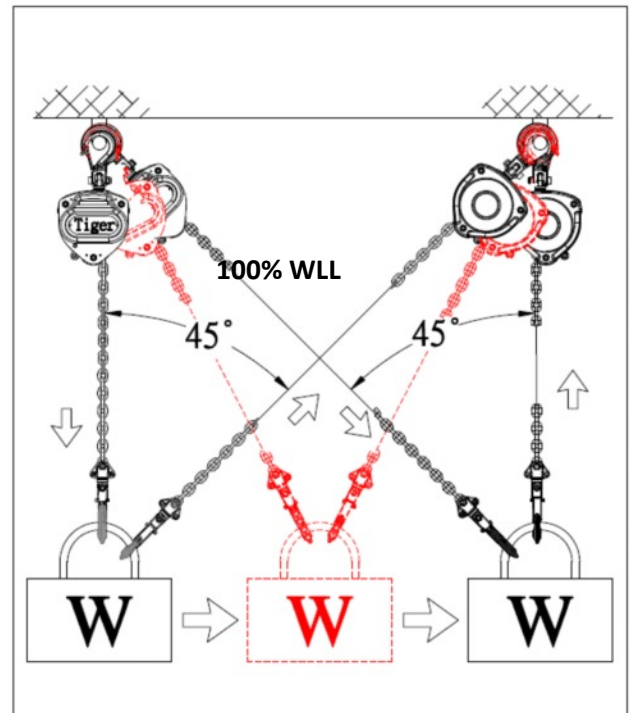

Temperature Range:

Operating temperature range -40°C to +50°C - far exceeding the requirements of current standards.



Mechanical Efficiency:

All major components are heat treated and precisely machined to ensure long term smooth operation. High gear ratios keep physical effort to a minimum.

Adaptor Components:

Drop forged adaptor maintaining maximum strength. 360° rotation and 180° pivot for maximum flexibility. Tested and certified to 4:1 factor of safety.



Self-locking (safety) hook, clevis shackle, reeveable egg (master) link or sling hook fittings available (for units up to 10t capacity).

Performance:

The SS20 has undergone a full test program that includes:

Type Testing

- Ultimate strength test, at least 4 times the Working Load Limit (WLL)
- Continuous cyclic testing of over 1500 cycles
- Chain end anchorage test, passing at least 2.5 times the WLL without any restriction of the brake or gears

Test on every hoist

- Proof loading at 1.5 times the rated capacity
- Light load testing at maximum of 2% rated capacity

Technical Data

Product Code	Capacity (tonne)	Effort (kg)	Dimensions (mm)							Load Chain		Standard HOL (m)	Mass @ std HOL (kg)	Mass for extra metre HOL (kg)
			A	B	C	D	E	F1	F2	Diameter (mm)	No. of falls			
SCB-0050	0.5	21	93	66	305	52	78	24	38	ø6.3	1	3	10.5	1.9
SCB-0100	1.0	25	93	66	340	63	87	28	45	ø6.3	1	3	11.5	1.9
SCB-0150	1.5	32	98	73	385	78	102	34	51	ø7.1	1	3	16.0	2.1
SCB-0200	2.0	34	101	79	420	87	113	35	53	ø8.0	1	3	20.0	2.4
SCB-0300	3.0	38	109	84	550	98	157	36	56	ø10.0	1	3	30.5	3.2
SCB-0500	5.0	37	101	79	575	122	209	49	70	ø8.0	3	3	37.5	5.2
SCB-1000	10.0	40	109	84	660	153	263	54	87	ø10.0	3	3	64.0	7.5
SCB-1500	15.0	41	109	84	840	225	378	59	81	ø10.0	5	3	128.5	11.8
SCB-2000	20.0	43	161	90	1050	148	360	81	110	ø10.0	6	3	178.5	14.2
SCB-3000	30.0	42	220	220	1200	388	388	91	135	ø10.0	10	3	307.0	23.8

See page 11 for more hook information



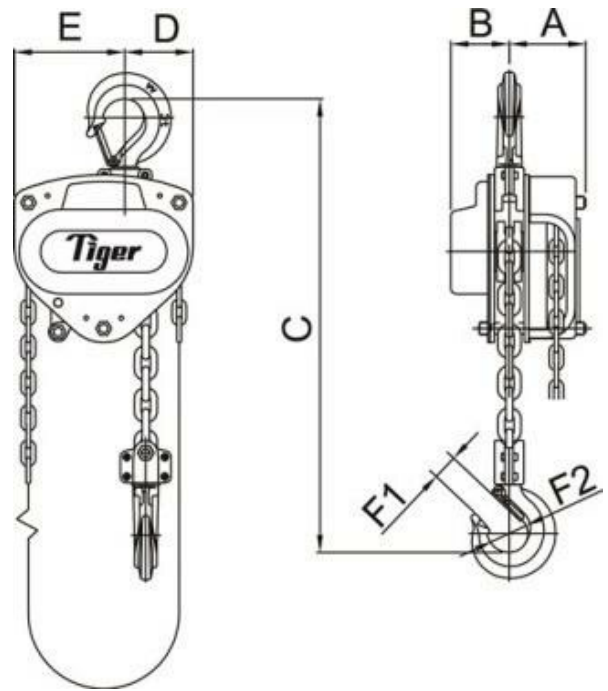
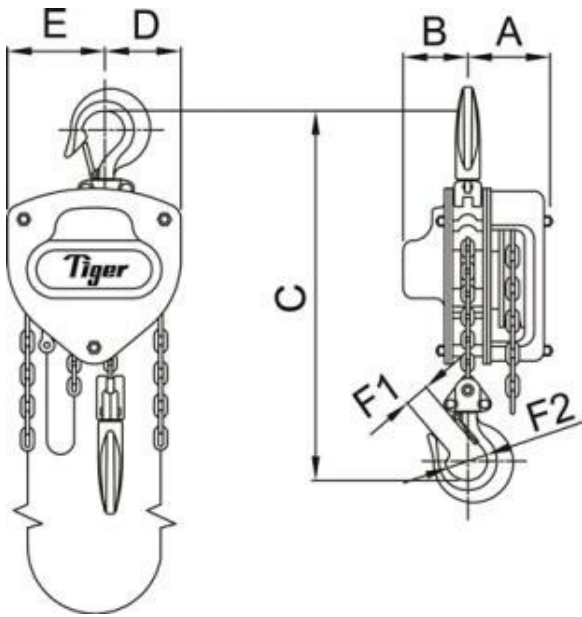

0.5t – 2.0t

3.0t single fall

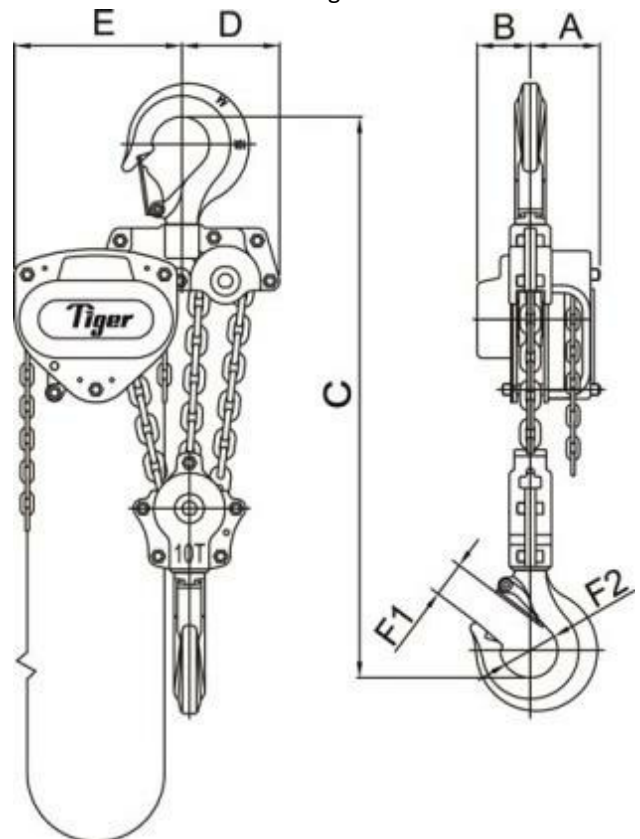
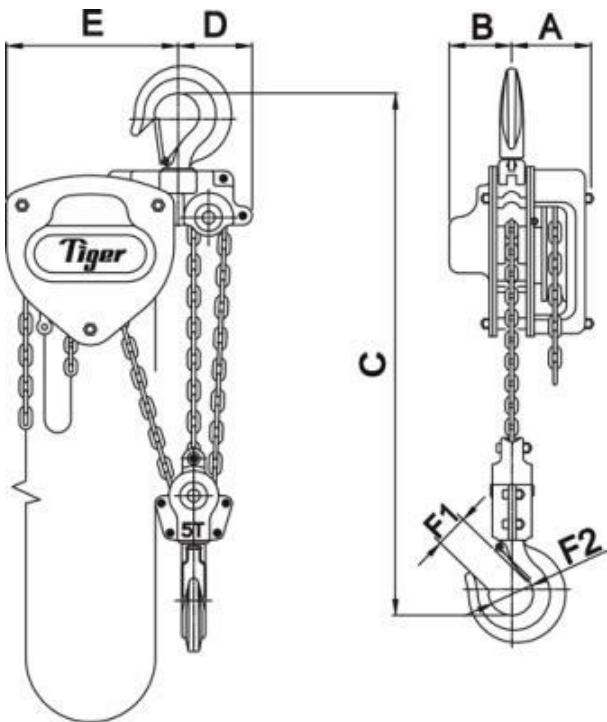

5.0t

10.0t



dlhonline.co.uk

0161 223 1990

Tiger Lifting



Home of the Tiger hoisting, winching and height safety ranges

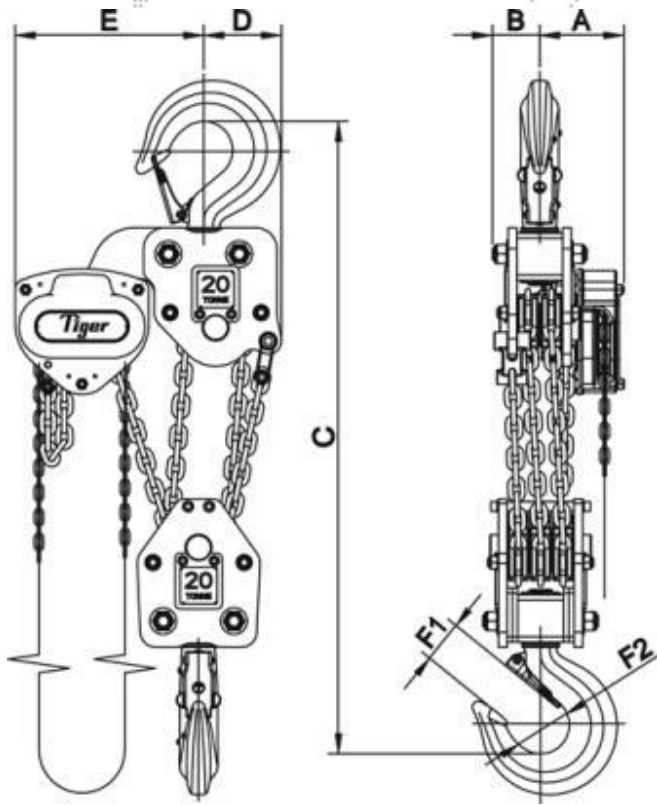

20.0t

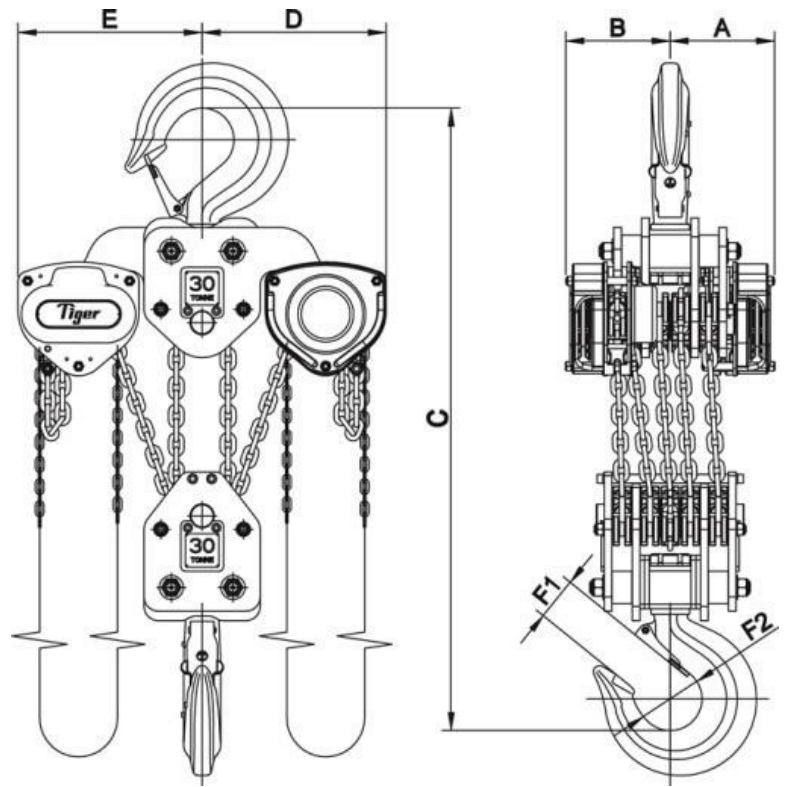

30.0t

www.dlhonline.co.uk

Div. of Dale Lifting and Handling

0161 223 1990

sales@dale-lifting.co.uk

SGS

QMS
ISO 9001
REGISTERED

QMS
ISO 14001
REGISTERED

LEEA
Full Member

Hook Technical Data

Capacity (Tonnes)	Collar measurements (mm)		Hook thickness at point shown in diagram (mm)		Hook throat Opening (mm)	"EZ Check" measurement (mm)
	a	b	c	d		
0.5	8	13.5	19	15	29	47
1.0	8	13.5	23	17	34	52
1.5	10	15.5	26	21	39	59
2.0	10	17.5	30	22	42	64
3.0	12.5	20	37	32	42	76
5.0	19	30	43	36	58	86
10.0	20	33	52	48	70	121
20.0	-	48	77	72	90	162
30.0	-	56	94	78	102	177

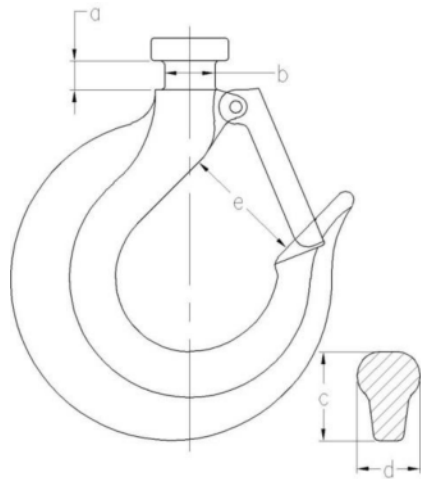

Traditional Tiger Hooks

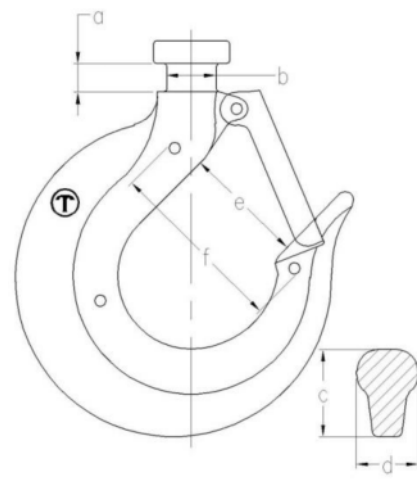

Tiger Hooks with new "EZ Check" 3 point marking system

SS20 chain blocks are fitted with the patent pending Tiger "EZ check" 3 point marking system. With this system a quick check that the A and B measurements are the same (as shown in the diagram below) will indicate if the hooks have stretched. If $A \leq B$ the hook is fine; If $A > B$ the hook needs to be replaced:

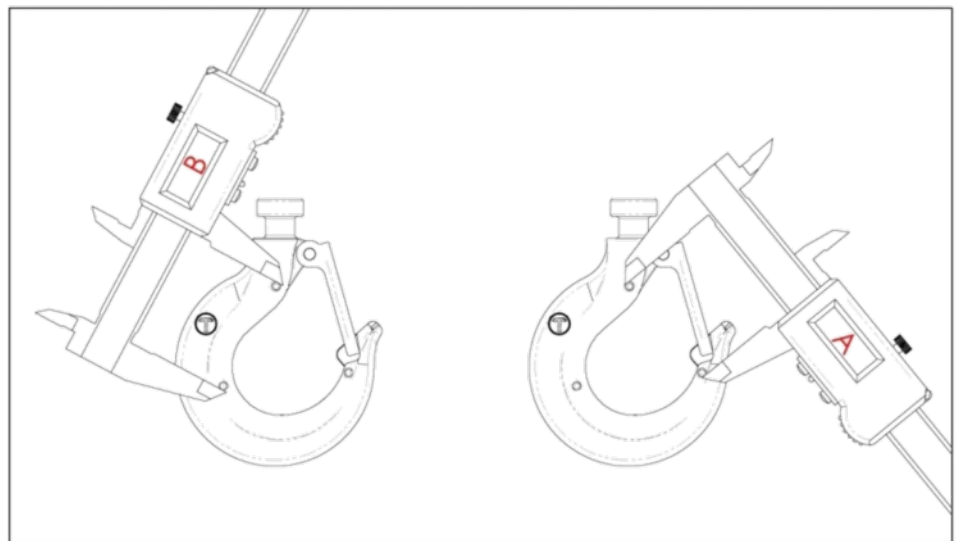

Due to our policy of continual product development, dimensions, weights and specifications may change without prior notice. Please check with your Tiger sales team when ordering.