

Tiger Combination Chain Hoist & Trolley



Corrosion resistant option

Main Features

- Range from 500kg – 10000kg
- Ideal for locations where headroom is limited
- Geared and plain trolley versions available
- Twin bar or single bar trolley options
- Extended beam width available
- Corrosion or Spark Resistant versions available



Tiger Combination Chain Hoist & Trolley

Certification:

Each unit comes fully certified with a test certificate or an EC Declaration of Conformity stating compliance with the essential health and safety requirements of the Machinery Directive 2006/42/EC.



Data Table

Single Bar Trolley & Chain Block Combinations

Product Code	Capacity (tonne)	Dimensions (mm)						Mass Kg @ std HOL		D - Extended width (mm)
		A	B		C	H	D (track width)	Plain 3m HOL	Geared 3m HOL	
			Plain	Geared						
CCBTPS-0050 CCBTGS-0050	0.5	195	106	165	106	310	62-128	16.2	20.2	62-203
CCBTPS-0100 CCBTGS-0100	1.0	213	113	170	113	350	62-128	19.8	23.7	62-203
CCBTPS-0200 CCBTGS-0200	2.0	236	136	182	136	450	88-154	33.2	37.7	88-230
CCBTPS-0300 CCBTGS-0300	3.0	277	146	187	146	530	88-154	48.52	53.8	88-230

Technical Drawings

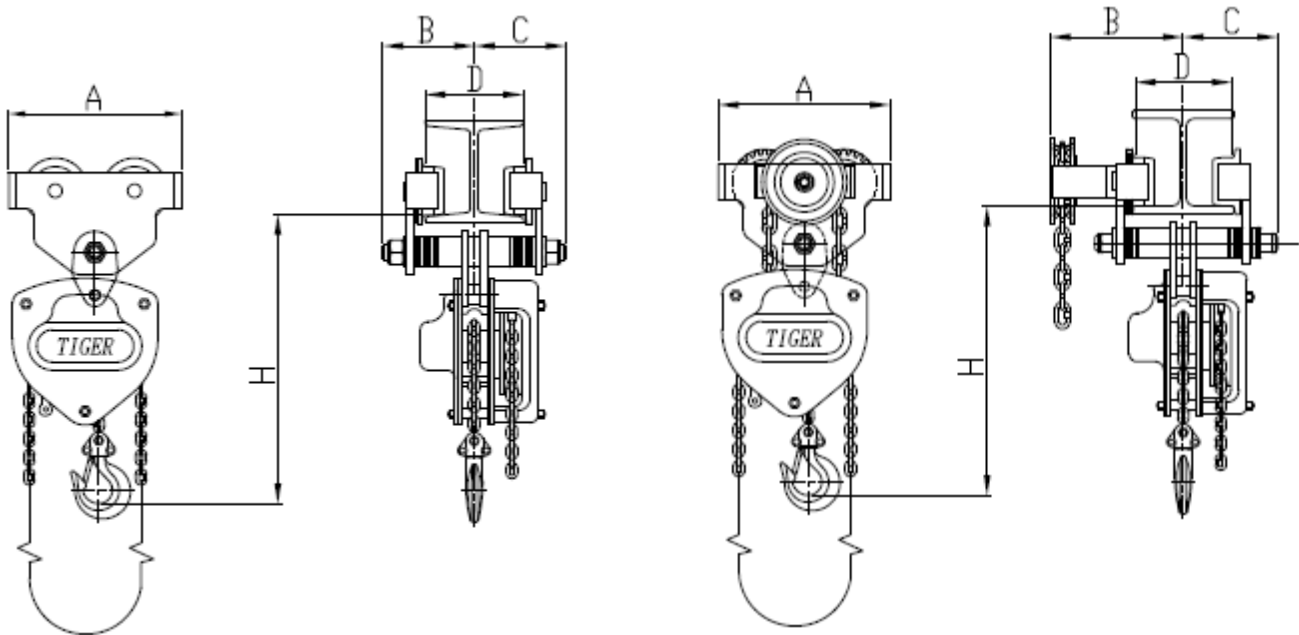

0.5t – 2.0t & 3.0t single bar plain trolley

0.5t – 2.0t & 3.0t single bar geared trolley



Tiger Combination Chain Hoist & Trolley

Data Table

Twin Bar Trolley & Chain Block Combinations

Product Code	Capacity (tonne)	Dimensions (mm)						Mass Kg @ std HOL		D - Extended width (mm)
		A	B		C	H	D (track width)	Plain 3m HOL	Geared 3m HOL	
			Plain	Geared						
CCBTPT-0050 CCBTGT-0050	0.5	179	109	168	109	316	62-128	17.1	21.1	62-203
CCBTPT-0100 CCBTGT-0100	1.0	195	111	178	111	342	62-128	20.4	24.4	62-203
CCBTPT-0200 CCBTGT-0200	2.0	235	134	184	134	446	88-154	33.9	38.4	88-230
CCBTPT-030T CCBTGT-030T	3.0	263	145	184	145	435	88-154	45.88	58.38	88-230
CCBTPT-0500 CCBTGT-0500	5.0	307	169	206	169	545	106-194	69.0	74.6	106-305
CCBTPT-1000 CCBTGT-1000	10.0	429	252	327	252	730	150-320	185.0	200.0	

(0.5t-2t twin bar available as special orders)

Technical Drawings

Twin Bar Plain Trolley Combinations

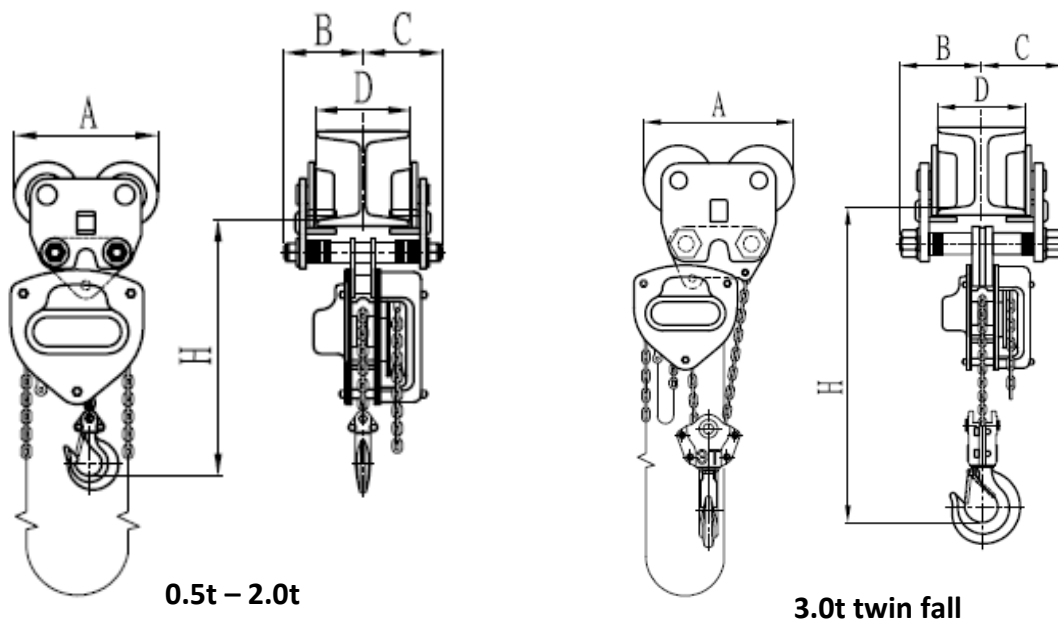

SGS



26 January 2015

Page 3 of 5

dlhonline.co.uk

0161 223 1990

Tiger Combination Chain Hoist & Trolley

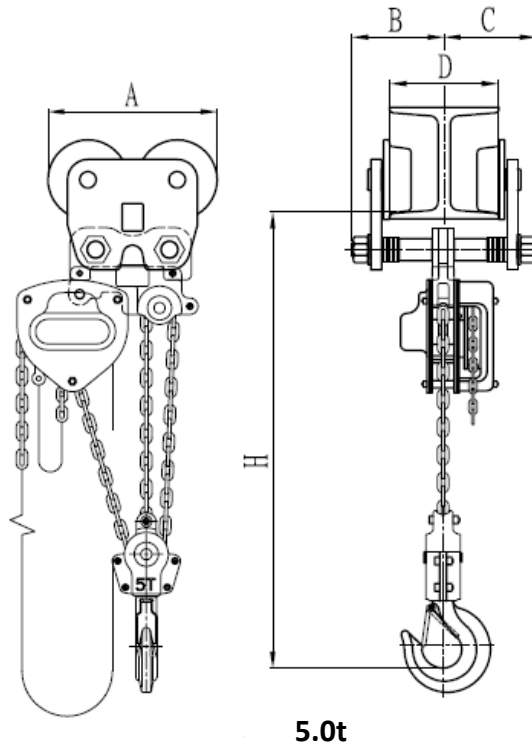

5.0t

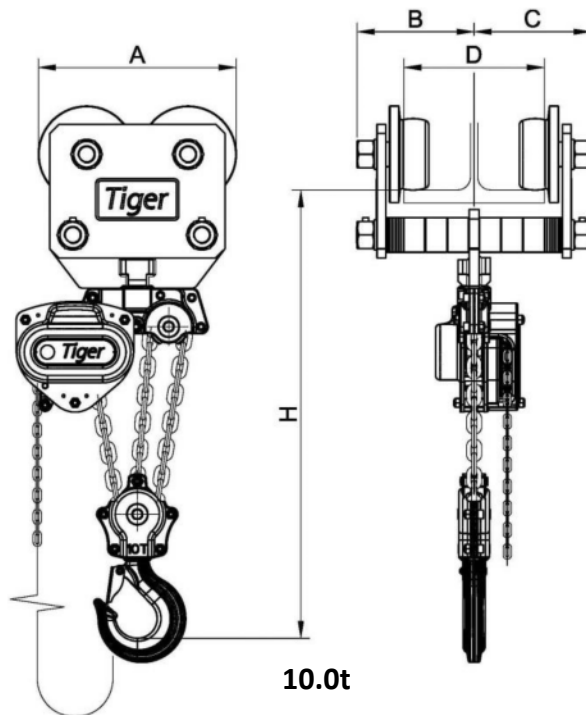

10.0t



Tiger Combination Chain Hoist & Trolley

Twin Bar Geared Trolley Combinations

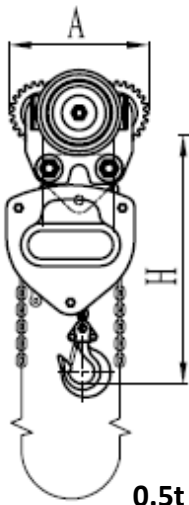

0.5t – 2.0t

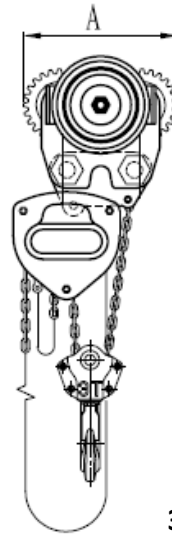
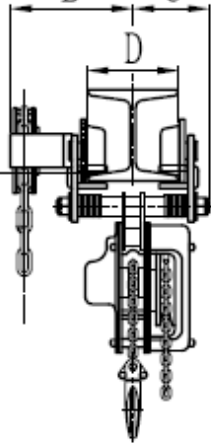

3.0t twin fall

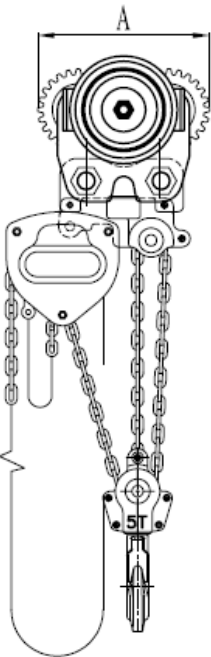
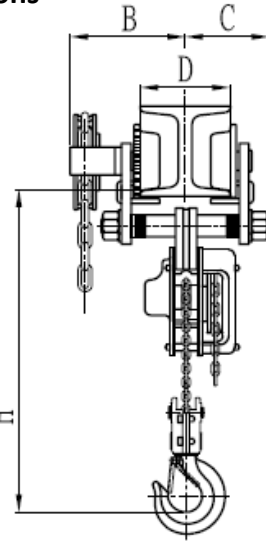

5.0t

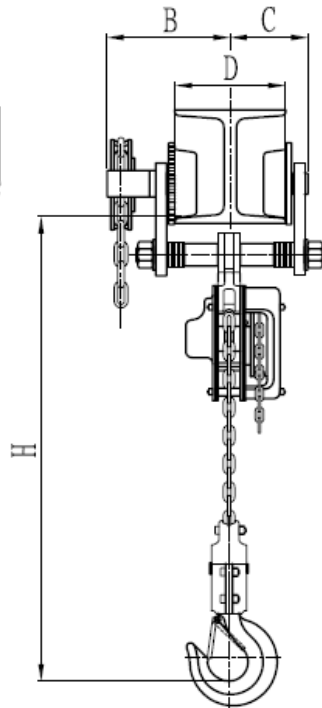

10.0t

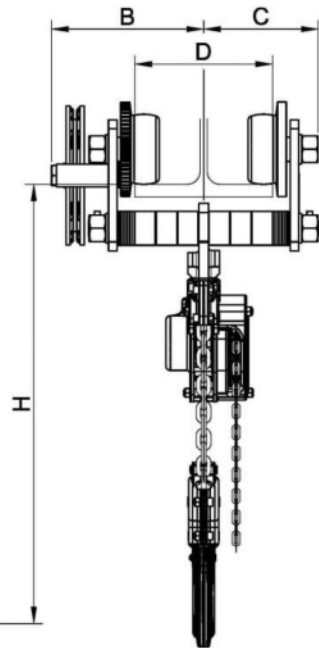

Due to our policy of continual product development, dimensions, weights and specifications may change without prior notice. Please check with your Tiger sales team when ordering.



26 January 2015

Page 5 of 5

DLHONLINE Division of Dale Group of Companies
 Dale Lifting and Handling Specialists
 2 Kelbrook Road Manchester M11 2QA
 Website www.dlhonline.co.uk Email sales@dale-lifting.co.uk