

VSIII 'MEDIUM DUTY' HAND CHAIN HOISTS

Get a quote

Hand chain hoist model VSIII

Capacities: 250 - 50000kg

The Yale VSIII hand chain hoist combines all the features expected by the user:
- Quality, Safety, and Performance - at a favourable price.

***SUITABLE FOR FLEETING. For further details please contact the sales office.**

Extremely low overall height allows for optimal use of headroom. Fully enclosed stamped steel housing allows for outdoor use. The hooks are equipped with robust safety latches and can rotate 360°.

Having many years of experience with this solid product, Yale have now extended the VSIII series by adding load capacities 10t, 20t, 30t and 50t.

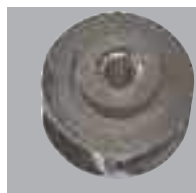

Load chain sheave with needle bearing



Side plate with ball bearing



Housing cover with ball bearing

VSIII 'MEDIUM DUTY' HAND CHAIN HOISTS

Technical data / dimensions:

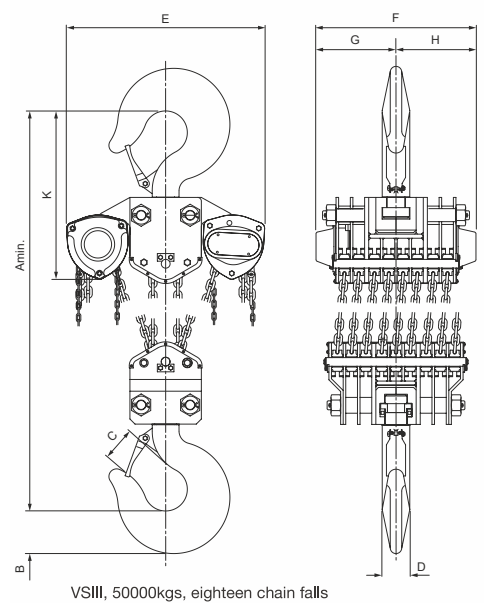
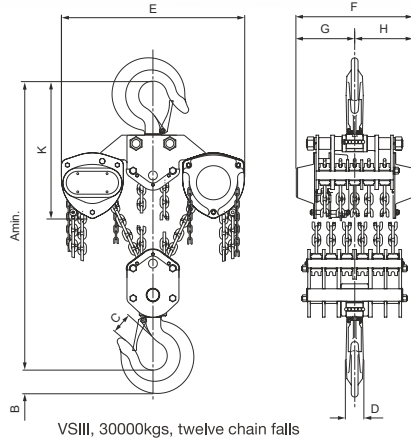
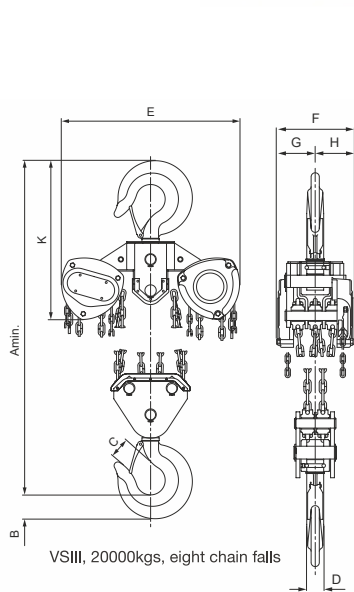
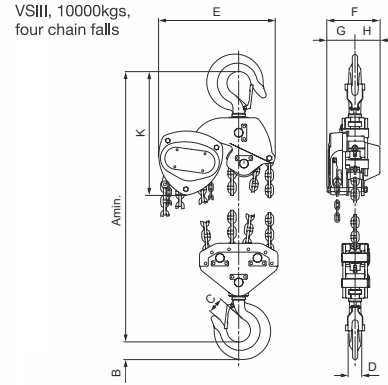
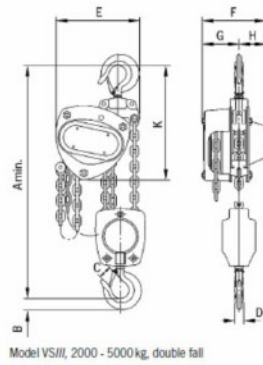
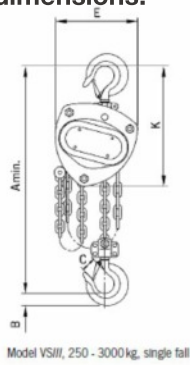

Model	Load chain dimension mm	Technical specification								
		A (min) mm	B mm	C mm	D mm	E mm	F mm	G mm	H mm	K mm
VSIII 0.25/1	4 x 12	290	12	26	11	118	113	65	48	190
VSIII 0.5/1	5 x 15	350	21	23	16	145	140	80	60	240
VSIII 1.0/1	6 x 18	380	28	27	20	158	155	87	68	270
VSIII 2.0/1	8 x 24	460	36	35	29	205	180	94	86	320
VSIII 2.0/2	6 x 18	490	36	35	29	170	155	87	68	285
VSIII 3.0/1	10 x 30	570	45	40	29	240	210	110	100	370
VSIII 3.0/2	8 x 24	580	45	40	29	220	175	94	81	340
VSIII 5.0/2	10 x 30	700	47	45	40	250	190	95	95	410
VSIII 10/4	10 x 30	860	63	65	47	463	104	55	50	448
VSIII 20/8	10 x 30	950	90	86	69	860	200	100	100	508
VSIII 30/12	10 x 30	1112	90	85	76	704	410	225	186	528
VSIII 50/18	10 x 30	1700	165	135	108	776	627	314	314	656

Model	Capacity (WLL) kg	Falls of load chain	Standard lift height mtr	Weight at std HOI kg	to suit hol mtr	Chain containers* part no.
VSIII 0.25/1	250	1	3	3.9	12	N04100020
VSIII 0.5/1	500	1	3	9.0	12/18	N04100014/9
VSIII 1.0/1	1000	1	3	11.5	12	N04100015
VSIII 2.0/1	2000	1	3	19.0	12	N04100016
VSIII 2.0/2	2000	2	3	17.3	6	N04100015
VSIII 3.0/1	3000	1	3	31.0	10/20	N04100017/8
VSIII 3.0/2	3000	2	3	27.0	6	N04100016
VSIII 5.0/2	5000	2	3	43.0	5/10	N04100017/8
VSIII 10/4	10000	4	3	78.5	-	-
VSIII 20/8	20000	8	3	197	-	-
VSIII 30/12	30000	12	3	268	-	-
VSIII 50/18	50000	18	3	540	-	-

*Other chain containers are available on request.

DLHONLINE Division of Dale Group of Companies

Dale Lifting and Handling Specialists

2 Kelbrook Road Manchester M11 2QA

Website www.dlhonline.co.uk Email sales@dale-lifting.co.uk

Tel 0161 223 1990 Fax 0161 223 6767