

5PA5 / 5PA10

ENSIGN SERIES

The Ensign series portable davit cranes are ideal for many applications. Simple set-up and easy to use. This economical series is specially designed for clearance, lift height, and ergonomic operation.



500 lb (225 kg) and 1200 lb (544 kg) Capacity Portable Davit Cranes

- Light and portable
- Adjustable Boom Angle
- Adjustable Sheave Block
- Quick-Mount Winch Bracket
- Roller Bearing for Easy 360° Rotation
- Manual or Power Winch Operation
- Five Corrosion-Resistant Finishes
- Easy, No-Tools Assembly/Disassembly
- Variety of Bases
- 2-Year Warranty



Model
5PA5-M1



HAND / POWER / HYDRAULIC / AIR WINCHES • DAVIT
CRANES

UK Agents DLHONLINE.CO.UK - 0161 223 1990 - sales@dale-lifting.co.uk

ENSIGN SERIES

ENSIGN 500

SERIES FEATURES

ADJUSTABLE SHEAVE BLOCK

Sheave easily adjusts without tools to 4 different positions allowing for a wide range of height and reach combinations.

ADJUSTABLE BOOM ANGLE

Convenient stainless steel adjustment screw, with comfortable turning knob, allows for easy, one-hand boom adjustment when not under load.

QUICK-MOUNT WINCH BRACKET

A variety of Thern winches can be attached to the bracket. After a winch is attached to the bracket, the bracket is easily mounted (without tools) to any of three convenient/ergonomic positions on the mast via quick-connect pins.

NYLATRON FLANGE BEARING

The Ensign 500 features a nylatron bearing that supports the mast at the top of the base to assist with the crane's 360° smooth rotation.

TAPERED ROLLER BEARING

A tapered roller bearing, pinned to the bottom of the mast, allows the crane to rotate 360° under load. Standard only on the Ensign 500.

ROLLER/BALL BEARING*

Standard on Ensign 1000, the specially designed roller/ball bearing at top of base requires no tools for installation. Allows smooth, easy 360° crane rotation under load.

STAINLESS STEEL LOCK*

Stainless steel lock assembly keeps crane in position during winch operation and when not in use. Included with roller/ball bearing.

SERIES 5PA5
CAPACITY 500 LB
226 KG

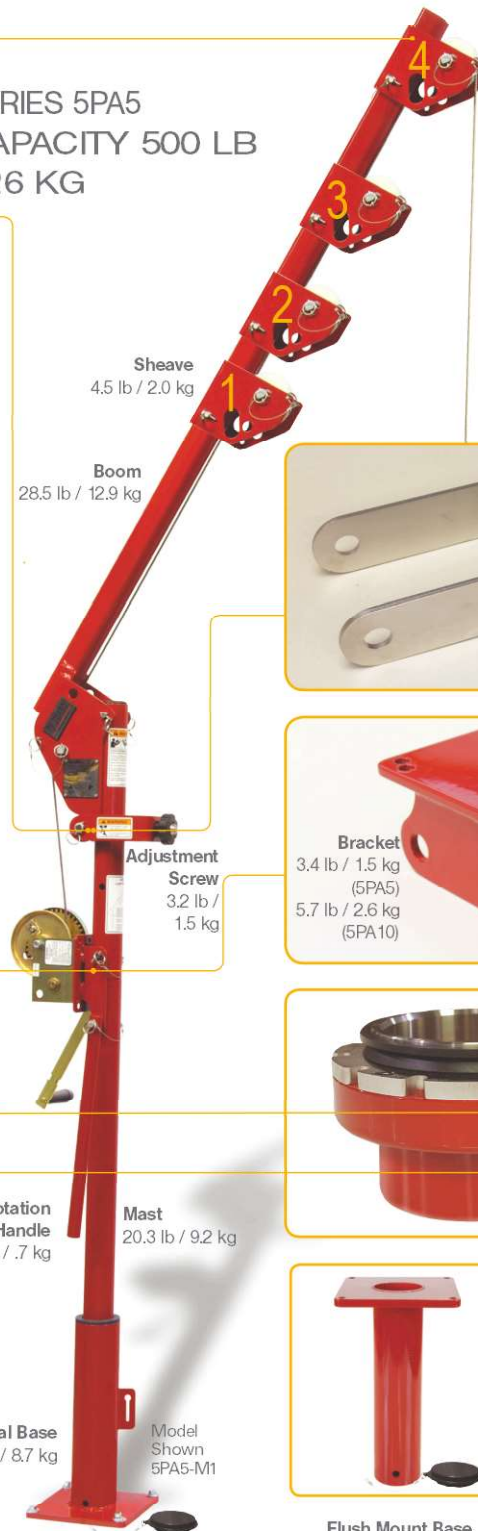

Sheave
4.5 lb / 2.0 kg

Boom
28.5 lb / 12.9 kg

Adjustment
Screw
3.2 lb / 1.5 kg

Rotation
Handle
1.6 lb / .7 kg

Mast
20.3 lb / 9.2 kg

Pedestal Base
19.2 lb / 8.7 kg

Model
Shown
5PA5-M1



Bracket
3.4 lb / 1.5 kg
(5PA5)
5.7 lb / 2.6 kg
(5PA10)



Flush Mount Base
19.2 lb / 8.7 kg



Wall Mount Base
20.7 lb / 9.4 kg



*Not available on the Ensign 500



FEATURES AND BENEFITS

ENSIGN 1000

SERIES 5PA10
CAPACITY 1200 LB
544 KG

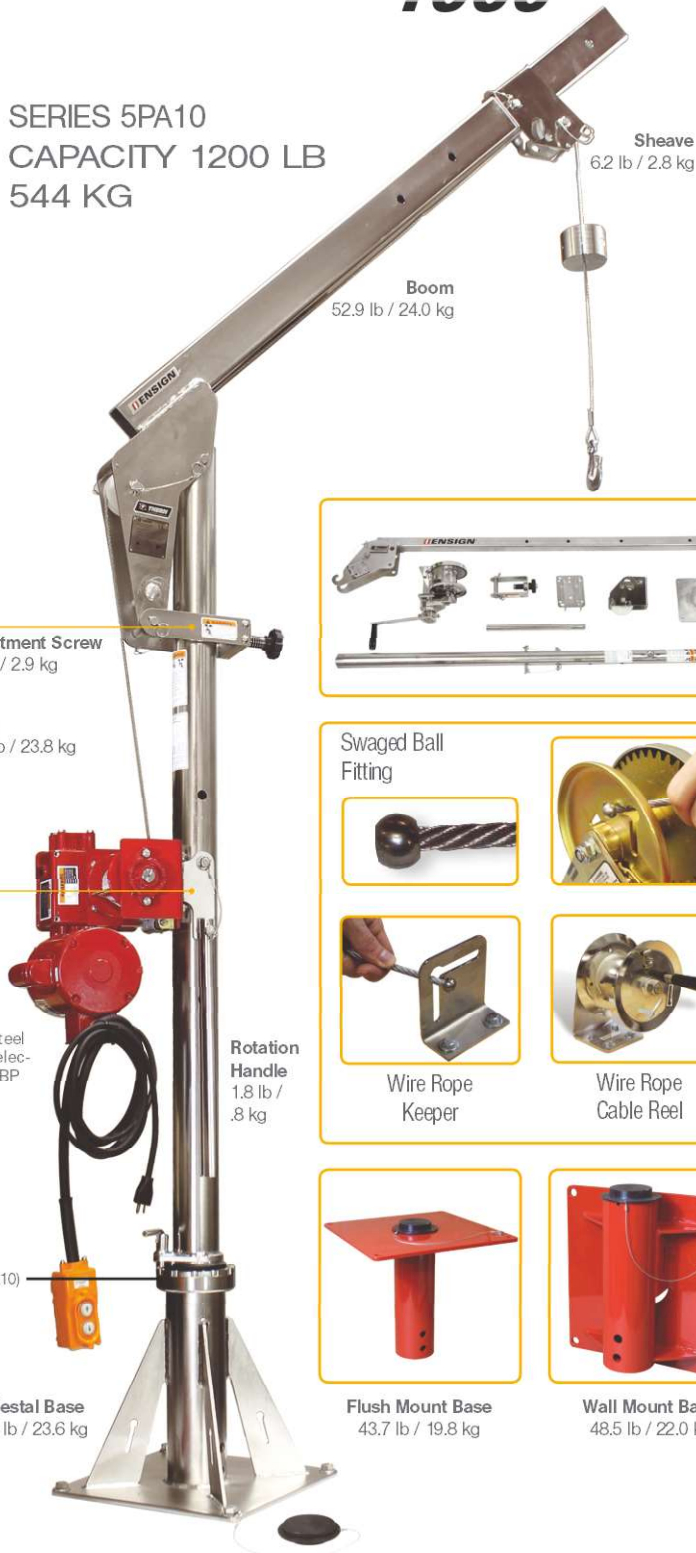

TRADITIONAL FEATURES

MANUAL OR POWER OPERATION

Thern davit cranes can be configured with a manual winch for short, infrequent lifts or a power winch for longer lifts or heavier loads. Choose from Thern's spur or worm gear hand winches or power winches with 115/1/60 as standard. Other voltages available as well as pneumatic, hydraulic or DC Volt power operation.

CORROSION RESISTANT FINISH

Electrostatic powder coated crane and stainless steel fasteners combine to resist corrosion in harsh environments. Other options available include: galvanized, stainless steel and epoxy finishes.

EASY ASSEMBLY/DISASSEMBLY

Quick-release stainless steel pins allow for easy assembly and quick disassembly for transport or storage. No tools required.

QUICK DISCONNECT ANCHOR

For quickly attaching or removing wire rope equipped with a swaged ball fitting - Allows the operator to leave the wire rope attached to the load at all times and simply remove the rope from the winch and attached to the optional wire rope keeper or cable reel.

VARIETY OF BASES

Pedestal, flush and wall mount bases allow for a variety of mounting solutions and are easily installed to a variety of solid surfaces with anchor bolts or other fastening methods. Bases sold separately. Base cap included with lanyard keeps water and debris out of base when crane is removed.

2 -YEAR WARRANTY

Industry-leading two-year limited warranty on all our products.



These products are not for lifting people, or things over people.

UK Agents DLHONLINE.CO.UK - 0161 223 1990 - sales@dale-lifting.co.uk



CRANES AND WINCHES



FINISHES

Crane Finishes for Ensign Series

All cranes come standard with Electrostatic Powder Coat red finish. Four optional finishes also offered are Galvanized, 304 or 316 Stainless Steel, and corrosion-resistant Epoxy. Custom colors are available per customer request - Please contact factory.



Finish	Code	Model Number		Options	Description
		ENSIGN 500	ENSIGN 1000		
Powder Coat (Red)	RED	5PA5	5PA10	Standard N/C	Red electrostatic powder coating applied to all cranes - Good
Galvanized	GAL	5PA5G	5PA10G	Optional/Extra	An economical choice that provides extra protection - Better
304 Stainless Steel	304SS	5PA5S	5PA10S	Optional/Extra	Electro-polished for added protection - Best
316 Stainless Steel	316SS	5PA5S316	5PA10S316	Optional/Extra	A higher level of corrosion protection - Premium
Epoxy (Gray)	EPX	5PA5X	5PA10X	Optional/Extra	3-part epoxy is impact, fire, water, and slip-resistant - Premium

WINCHES For Ensign Series

Hand Winches



Winch	Winch Model No.	Description	Finish	Approx. Ship Weight
M1	M4022PB-K	(5PA5) Spur gear hand winch with brake	Zinc Plated	17 lbs 7.7 kg
	M4312PB-K	(5PA10) Spur gear hand winch with brake		
M2	4WM2V-K	Worm gear hand winch with brake	Red Enamel	42 lbs 19.1 kg
M2X	4WM2VEGRA-K	Worm gear hand winch with brake	Epoxy Paint (Gray)	42 lbs 19.1 kg
M3	M4042PBSS-K	(5PA5) Stainless steel spur gear hand winch with brake	Stainless Steel	24 lbs 10.9 kg
	M4312PBSS-K	(5PA10) Stainless steel spur gear hand winch with brake		

All hand winches include disc brake for load control and steel gear covers to protect gears and help prevent injuries.

NOTE: Worm gear requires more turns with less effort than a spur gear winch.

Electric Winches

Electric Winch	Model No.	Line Speed		Finish	Power	Control (Pendant)	Approx. Ship Weight	
		1st Layer	Full Drum					
E2	4WP2V-K	8 fpm	13 fpm	Enamel Paint	220 Volt, AC, Single Phase	6 ft	85 lbs	39 kg
E2X	4WP2VEGRA-K	8 fpm	13 fpm	Epoxy Paint	220 Volt, AC, Single Phase	6 ft	85 lbs	39 kg
E4	4777-K	13 fpm	22 fpm	Enamel Paint	220 Volt, AC Single Phase	6 ft	110 lbs	50 kg
E4X	4777EGRA-K	13 fpm	22 fpm	Epoxy Paint	220 Volt, AC Single Phase	6 ft	110 lbs	50 kg
E4DC	4777DC-K	13 fpm	22 fpm	Enamel Paint	12 Volt, DC	10 ft	124 lbs	57 kg
E4XDC	4777DCEGRA-K	13 fpm	22 fpm	Epoxy Paint	12 Volt, DC	10 ft	124 lbs	57 kg



All electric winches mount on boom via quick mount bracket and are equipped with internal break for load control.



BASES AND WIRE ROPE



BASES For Ensign Series

Select the appropriate base(s) for your application from the chart below. Matching your crane with multiple bases provides optimal worksite flexibility and an economical solution for servicing multiple lift stations.



Finish	Pedestal		Flush		Wall	
	5PA5	5PA10	5PA5	5PA10	5PA5	5PA10
Powder Coat Paint	5BP5	5BP10	5BF5	5BF10	5BW5	5BW10
Galvanized	5BP5G	5BP10G	5BF5G	5BF10G	5BW5G	5BW10G
304 Stainless Steel	5BP5S	5BP10S	5BF5S	5BF10S	5BW5S	5BW10S
316 Stainless Steel	5BP5S316	5BP10S316	5BF5S316	5BF10S316	5BW5S316	5BW10S316
Epoxy Paint	5BP5X	5BP10X	5BF5X	5BF10X	5BW5X	5BW10X
Approximate Ship Weight	21 lbs (9.5 kg)	56 lbs (25.4 kg)	21 lbs (9.5 kg)	47 lbs (21.3 kg)	23 lbs (10.4 kg)	52 lbs (23.6 kg)



WIRE ROPE Assembly (sold separately) For Ensign Series

Wire Rope Length	Galvanized Aircraft Cable		304 Stainless Steel Rope		316 Stainless Steel Rope	
	3/16" Dia	1/4" Dia.	3/16" Dia.	1/4" Dia.	3/16" Dia.	1/4" Dia.
Wire Rope Ratings*	1200 lbs (544 kg)	2000 lbs (907 kg)	1000 lbs (454 kg)	1800 lbs (816 kg)	800 lbs (363 kg)	1400 lbs (635 kg)
20 ft - 6 m	WA19-20NS	WA25-20NS	WS19-20NS	WS25-20NS	WSS19-20NS	WSS25-20NS
28 ft - 8.5 m	WA19-28NS	WA25-28NS	WS19-28NS	WS25-28NS	WSS19-28NS	WSS25-28NS
36 ft - 10.9 m	WA19-36NS	WA25-36NS	WS19-36NS	WS25-36NS	WSS19-36NS	WSS25-36NS
45 ft - 13.7 m	WA19-45NS	WA25-45NS	WS19-45NS	WS25-45NS	WSS19-45NS	WSS25-45NS
60 ft - 18.2 m	WA19-60NS	WA25-60NS	WS19-60NS	WS25-60NS	WSS19-60NS	WSS25-60NS
75 ft - 22.8 m	WA19-75NS	WA25-75NS	WS19-75NS	WS25-75NS	WSS19-75NS	WSS25-75NS
90 ft - 27.4 m	WA19-90NS	-	WS19-90NS	-	WSS19-90NS	-

These winches and cranes are sold without wire rope. However, we carry top quality wire rope assemblies optimally designed for use with our winches and cranes. The assemblies above are equipped with a swaged ball fitting and swivel hook (Enamel w/Galvanized rope or Stainless Steel with SS rope)

*Based on 3.5:1 design factor NOTE: 1/8" wire rope is available with a reduced load rating. Please contact the factory.

 These products are not for lifting people, or things over people.

UK Agents DLHONLINE.CO.UK - 0161 223 1990 - sales@dale-lifting.co.uk



PERFORMANCE

ENSIGN 500



Ensign 500 Lift Below Floor² Level

Lift Below ¹ Floor				Wire Rope Diameter		Wire Rope Length ³		Winch Configurations				
Minimum (B4)		Maximum (B1)		(in)	(mm)	(ft)	(m)	M1	M2	M3	E2	E4
(ft)	(m)	(ft)	(m)									
0	0	5	1.5	3/16	5	20	6.0	x	-	x	-	x
8	2.4	13	3.9	3/16	5	28	8.5	x	-	x	-	x
16	4.8	21	6.4	3/16	5	36	10.9	x	-	x	-	x
25	7.6	30	9.1	3/16	5	45	13.7	x	-	x	-	x
40	12.1	45	13.7	3/16	5	60	18.2	-	-	x	-	x
55	16.7	60	18.2	3/16	5	75	22.8	-	-	x	-	x
70	21.3	75	22.8	3/16	5	90	27.4	-	-	-	-	x
For long lifts (Up to 240' (73.1m)) please contact factory												
0	0	5	1.5	1/4	6	20	6.0	-	x	x	x	x
8	2.4	13	3.9	1/4	6	28	8.5	-	x	x	x	x
16	4.8	21	6.4	1/4	6	36	10.9	-	x	x	x	x
25	7.6	30	9.1	1/4	6	45	13.7	-	x	x	x	x
40	12.1	45	13.7	1/4	6	60	18.2	-	-	-	-	x

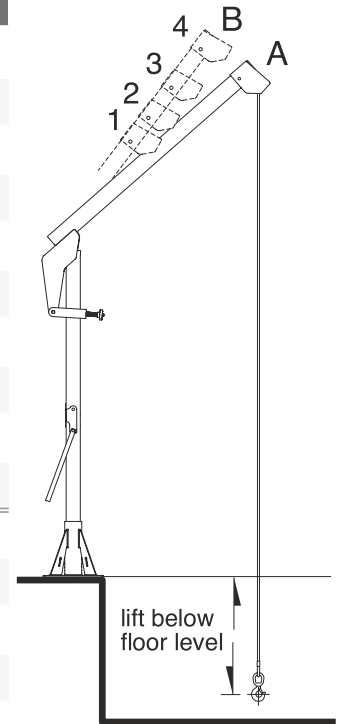

¹ Lift below floor level varies depending on boom position and base configuration. For longer lifts, please contact factory.

² Performance Characteristics are for standard products referred to in this manual. Non-standard products may vary from the original design. Contact Thern, Inc. for this information.

³ Wire rope assemblies include a hood and a swaged ball fitting to work with quick disconnect anchor on winches, cable spooler and wire rope keeper. 316SS wire rope is also available. Please contact the factory.

IMPORTANT:

It is the owner or operator's responsibility to determine the suitability of the equipment to its intended use. Study all applicable codes, manuals and regulations. Be sure to read the Owner's Manual supplied with the equipment before operating it.



PERFORMANCE

ENSIGN 500

Ensign 500 on Pedestal Base Performance Ratings²

Boom Position	Load Rating		Hook Reach		Hook Height	
	(lb)	(kg)	(in)	(mm)	(in)	(mm)
A-1	500	226	17	431	74	1879
A-2	400	181	22	558	79	2006
A-3	300	136	28	711	87	2209
A-4	250	113	36	914	96	2438
B-1	500	226	14	355	76	1930
B-2	400	181	17	431	83	2108
B-3	300	136	22	558	91	2311
B-4	250	113	28	711	101	2565

¹ Lift below floor level varies depending on boom position and base configuration. For longer lifts, please contact factory.

² Performance Characteristics are for standard products. Non-standard products may vary from the original design. Contact Them, Inc. for this information.

Pedestal Base 5BP5

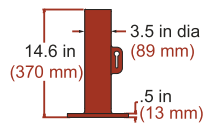
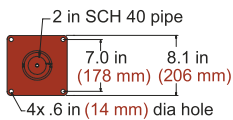

Flush/Wall Mount Performance Ratings²

Boom Position	Load Rating		Hook Reach		Hook Height	
	(lb)	(kg)	(in)	(mm)	(in)	(mm)
A-1	500	226	17	431	60	1524
A-2	400	181	22	558	65	1651
A-3	300	136	28	711	73	1854
A-4	250	113	36	914	82	2082
B-1	500	226	14	355	62	1574
B-2	400	181	17	431	69	1752
B-3	300	136	22	558	77	1955
B-4	250	113	28	711	87	2209

¹ Lift below floor level varies depending on boom position and base configuration. For longer lifts, please contact factory.

² Performance Characteristics are for standard products. Non-standard products may vary from the original design. Contact Them, Inc. for this information.

Wall-Mount Base 5BW5

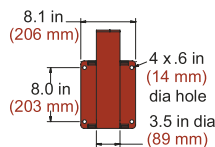
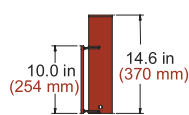
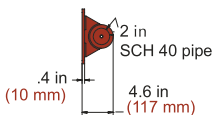

Flush-Mount Base 5BF5

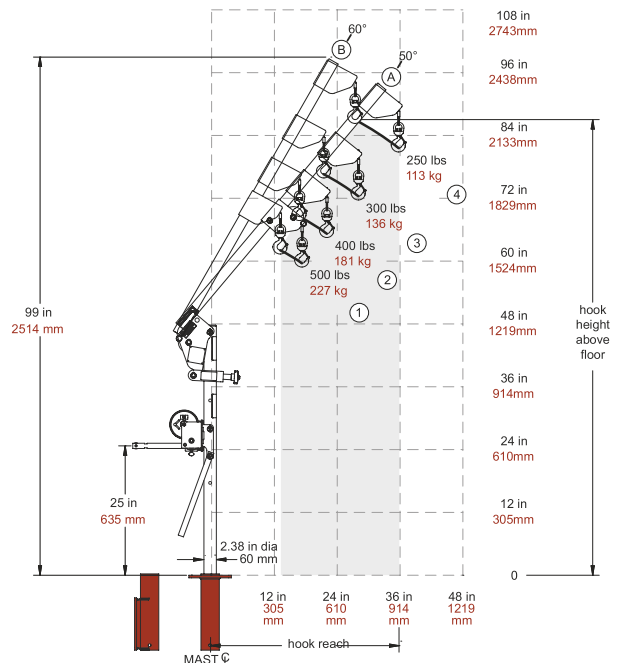
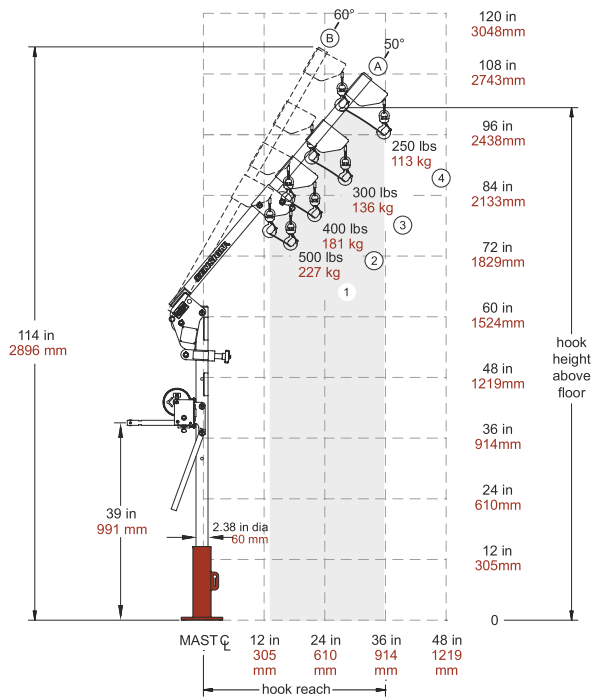
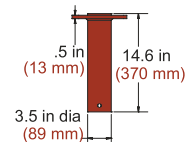
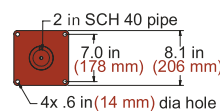

These products are not for lifting people, or things over people.



PERFORMANCE

ENSIGN 1000



Ensign 1000 Lift Below Floor² Level

Lift Below ¹ Floor				Wire Rope Diameter		Wire Rope Length ³		Winch Configurations				
Minimum (B4)		Maximum (B1)						M1	M2	M3	E2	E4
(ft)	(m)	(ft)	(m)	(in)	(mm)	(ft)	(m)					
5	1.5	9	2.7	3/16	5	28	8.5	x	-	x	-	x
13	3.9	17	5.1	3/16	5	36	10.9	x	-	x	-	x
22	6.7	26	7.9	3/16	5	45	13.7	x	-	x	-	x
37	11.2	41	12.4	3/16	5	60	18.2	x	-	x	-	x
52	15.8	56	17.0	3/16	5	75	22.8	x	-	x	-	x
67	20.4	71	21.6	3/16	5	90	27.4	x	-	x	-	x
97	29.5	101	30.7	3/16	5	120	36.5	-	-	-	-	x
For long lifts (Up to 240' (73.1m)) please contact factory												
5	1.5	9	2.7	1/4	6	28	8.5	-	x	x	x	x
13	3.9	17	5.1	1/4	6	36	10.9	-	x	x	x	x
22	6.7	26	7.9	1/4	6	45	13.7	-	x	x	x	x
37	11.2	41	12.4	1/4	6	60	18.2	-	x	x	x	x
52	15.8	56	17.0	1/4	6	75	22.8	-	-	-	-	x
5	1.5	9	2.7	5/16	8	28	8.5	x	-	x	-	x
13	3.9	17	5.1	5/16	8	36	10.9	x	-	x	-	x
22	6.7	26	7.9	5/16	8	45	13.7	-	-	-	-	x

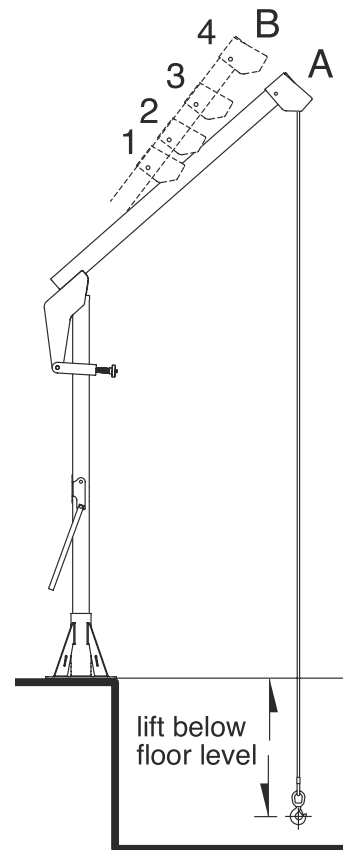

¹ Lift below floor level varies depending on boom position and base configuration. For longer lifts, please contact factory.

² Performance Characteristics are for standard products referred to in this manual. Non-standard products may vary from the original design. Contact Them, Inc. for this information.

³ Wire rope assemblies include a hood and a swaged ball fitting to work with quick disconnect anchor on winches, cable spooler and wire rope keeper. 316SS wire rope is also available. Please contact the factory.

IMPORTANT:

It is the owner or operator's responsibility to determine the suitability of the equipment to its intended use. Study all applicable codes, manuals and regulations. Be sure to read the Owner's Manual supplied with the equipment before operating it.



PERFORMANCE

ENSIGN 1000

Ensign 1000 on Pedestal Base Performance Ratings²

Boom Position	Load Rating		Hook Reach		Hook Height	
	(lb)	(kg)	(in)	(mm)	(in)	(mm)
A-1	1200	544	26	660	93	2362
A-2	1000	453	32	812	98	2489
A-3	800	362	39	990	104	2641
A-4	650	294	48	1219	112	2844
B-1	1200	544	22	558	97	2463
B-2	1000	453	26	660	103	2616
B-3	800	362	32	812	110	2794
B-4	650	294	39	990	120	3048

¹ Lift below floor level varies depending on boom position and base configuration. For longer lifts, please contact factory.

² Performance Characteristics are for standard products. Non-standard products may vary from the original design. Contact Them, Inc. for this information.

Pedestal Base 5BP10

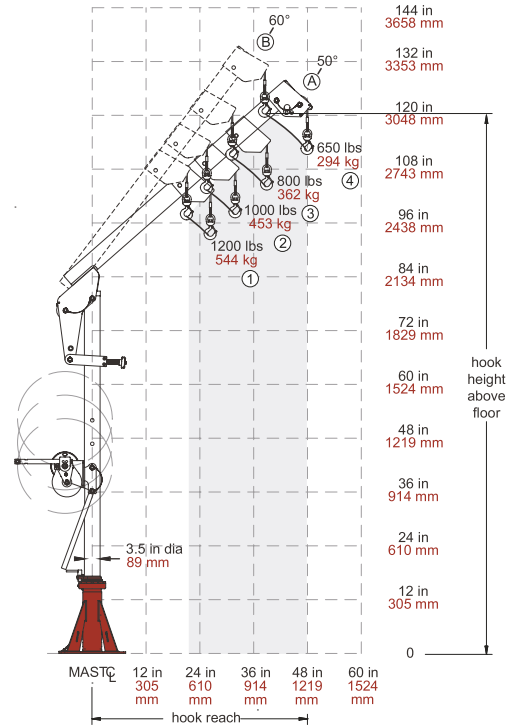
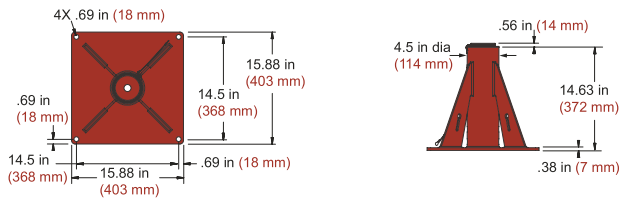

Flush/Wall Mount Performance Ratings²

Boom Position	Load Rating		Hook Reach		Hook Height	
	(lb)	(kg)	(in)	(mm)	(in)	(mm)
A-1	1200	544	26	660	79	2007
A-2	1000	453	32	812	84	2134
A-3	800	362	39	990	90	2286
A-4	650	294	48	1219	98	2489
B-1	1200	544	22	558	83	2108
B-2	1000	453	26	660	89	2261
B-3	800	362	32	812	96	2438
B-4	650	294	39	990	106	2692

¹ Lift below floor level varies depending on boom position and base configuration. For longer lifts, please contact factory.

² Performance Characteristics are for standard products. Non-standard products may vary from the original design. Contact Them, Inc. for this information.

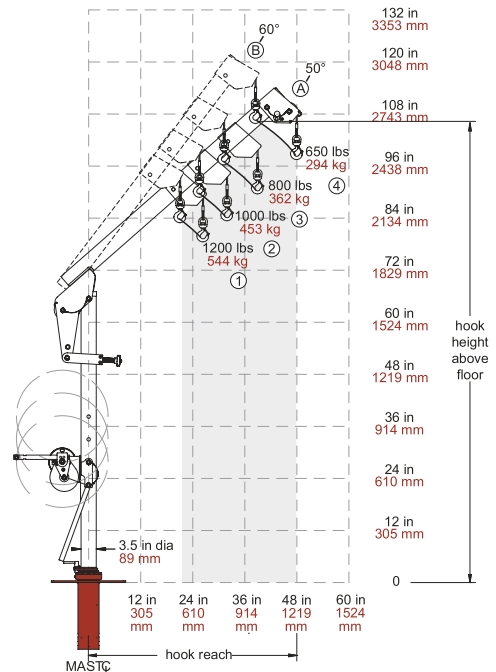

Wall-Mount Base 5BW10

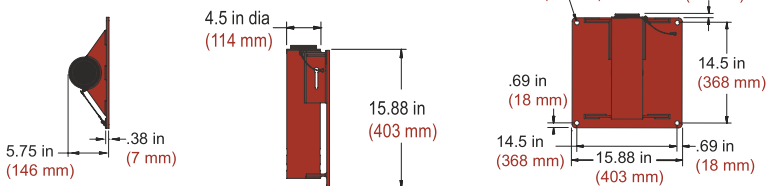

Flush-Mount Base 5BF10

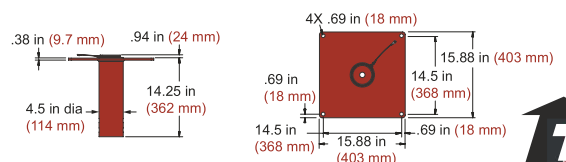

 These products are not for lifting people, or things over people.



ACCESSORIES

ACCESSORIES FOR ENSIGN SERIES

Item	Part Number	Description
Roller/Ball Bearing Comes Standard on 5PA10 (Not available on 5PA5)	5PT10BRG	Red electrostatic powder coat paint finish - Good
	5PT10BRG-S	304 Stainless steel electro-polished finish for added protection - Better
	5PT10BRG-S316	316 Stainless steel electro-polished finish for a higher level of protection - Best
	5PT10BRG-SS	304 Stainless steel - For use with stainless steel base only
	5PT10BRG-SS316	316 Stainless steel - For use with stainless steel base only
	5PT10BRG-X	3-part epoxy paint (gray) finish for higher level of protection - Premium
5PA5 Series Rotational Lock	5PA5LCK-S	Optional 5PA5 rotation lock holds crane position at 30° increments For pedestal and wall mount bases - 304 Stainless Steel
	5PA5LCK-S316	For pedestal and wall mount bases - 316 Stainless Steel
	5PQ5LCKF-S	For flush mount base - 304 Stainless Steel
	5PA5LCKF-S316	For flush mount base - 316 Stainless Steel
Base Anchor Kit	AN50A-5	4 Hilti® Zinc Plated Steel fasteners 1/2 X 5.50 STL KB-TZ
	AN50A-5S	4 Hilti® 304 Stainless Steel fasteners 1/2 X 5.50 SST304 KB-TZ
	AN50A-5S316	4 Hilti® 316 Stainless Steel fasteners 1/2 X 5.50 SST316 KB-TZ
	AN62A-6	4 Hilti® Zinc Plated Steel fasteners 5/8 X 6.00 STL KB-TZ
	AN62A-6S	4 Hilti® 304 Stainless Steel fasteners 5/8 X 6.00 SST304 KB-TZ
	AN62A-6S316	4 Hilti® 316 Stainless Steel fasteners 5/8 X 6.00 SST316 KB-TZ
Drill-Drive KitS	ED300-DW11	120 VAC, 11.5 amp, 300rpm drill-motor to power drive the hand winch. Only available for cranes configured with the M2 winch option. Includes 1-1/8" hex drive socket.
	ED300-DW06	CORDLESS KIT: 60 V Brushless Motor, 300rpm drill-motor to power drive the M2 hand winch option. Includes 1-1/8" hex drive socket.
Cable Spooler	RW50	316 stainless steel reel winds up wire rope when detached from crane.
Headache Ball	HB10-12-25	Red Painted 10lb fits 3/16" to 1/4" Rope
	HB10-25-38	Red Painted 10lb fits 1/4" to 3/8" Rope
	HB10S-12-25	Stainless Steel 10lb fits 3/16" to 1/4" Rope
	HB10S-25-38	Stainless Steel 10lb fits 1/4" to 3/8" Rope
Wire Rope Keeper	RK19-25S	Stainless steel bracket attaches to base or other structure to hold free end of the wire rope when detached from the crane.
	RK19-25S316	

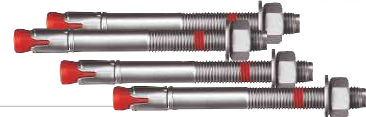

IMPORTANT:

It is the owner or operator's responsibility to determine the suitability of the equipment to its intended use. Study all applicable codes, manuals and regulations. Be sure to read the Owner's Manual supplied with the equipment before operating it.



OPTIONS

ADDITIONAL OPTIONS FOR ENSIGN SERIES

Them offers a variety of additional options you can choose to enhance your davit crane.

• FACTORY LOAD TEST

Upon request, Them can test your crane prior to shipping, up to 125% of rated load.

• EXTENDED 5-YEAR WARRANTY

Extend our standard 2-year warranty to 5 years .

• PE STAMP - PROFESSIONAL ENGINEER STAMP

Available upon request at time of order.

• CE MARK

Available upon request at time of order, CE mark for products sold into the European union.

• ATEX CLASSIFICATION

Specially rated for use in explosive settings. Available upon request at time of order.

• POWER WINCH OPERATION

AC electric in any voltage. DC electric, hydraulic and pneumatic power winches available.

• CUSTOM ELECTRIC CONTROLS

Them can build the high quality controls you need to operate your equipment.

• DRILL-DRIVEABLE WINCH

A worm gear hand winch is also available for operation with a 400 rpm max drill motor option.

• LIMIT SWITCH

Add an emergency safety shut-off to ensure safe operation.



CUSTOMIZATION

Customization is available for almost all Them products and should always be performed by our engineers to assure the changes meet our stringent quality standards. Below are some of our more common customization requests. Only factory modifications are covered under warranty.

• LONGER LIFT DISTANCES

Customized winch and crane configurations to accommodate longer lifts.

• CUSTOM COLORS & FINISHES

Custom colors and finishes are available to match your unique application

• EXTENDED BOOM AND MASTS

Them can extend mast heights and boom lengths to fit your needs

• RELOCATE THE WINCH

The winch can be relocated to fit confined spaces or height restrictions

• SPECIAL BASES

Custom bases or mounting requirements can be manufactured to meet your unique situation



 These products are not for lifting people, or things over people.



UK Agents DLHONLINE.CO.UK - 0161 223 1990 - sales@dale-lifting.co.uk
DALE Lifting and Handling Specialists - 2 Kelbrook Road - Manchester M11 2QA



Thern
Winches & Cranes

MADE IN USA 

Thern, Incorporated
World Headquarters
5712 Industrial Park Road Winona, MN USA
TF: 1-800-843-7648
Phone: 1-507-454-2996
www.thern.com

Thern Europe
Bedrijvenpark Twente 454e
7602 KM Almelo The Netherlands
Phone: +31-546-898-380
europe@thern.com