

300 kg Portable Lifting Davit

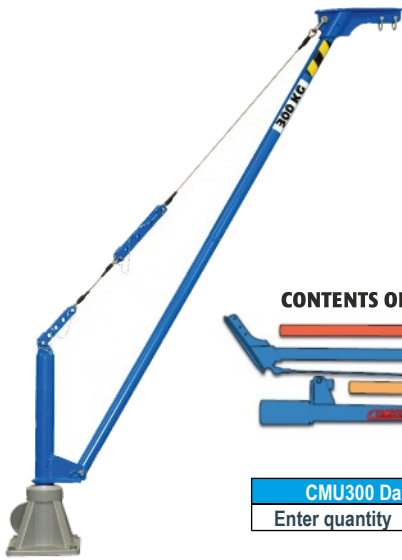

FEATURES

- SWL 300 kg capacity
- Adjustable span from 900 mm to 2 000 mm
- 2 height possible (2 jib extensions provided)
- Crane in 3 elements / very quick installation
- Weight of the set = 24 KG
- Davit carry bag provided
- Bearing mounted 360 degree pivot
- Powder coating on anodising
- 2 stainless steel shackles
- Maximum moment = 725 DaN.m.

BENEFITS

Removable, efficient and safe lifting solution, the CMU 300 Portable Lifting Davit improves the responsiveness of your teams.

Its aluminium structure guarantees optimal portability and facilitates interventions on hard-to-reach sites. Single man assembly,

8 span-height pairs as standard. Ideal for lifting loads in sewage treatment plants, and in general anywhere where a standard lifting davit cannot be used. Choice of fixed bases available.

CONTENTS OF THE BAG

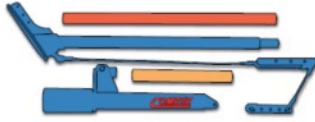

CMU300 Davit

Enter quantity

OPTIONAL POST EXTENSION

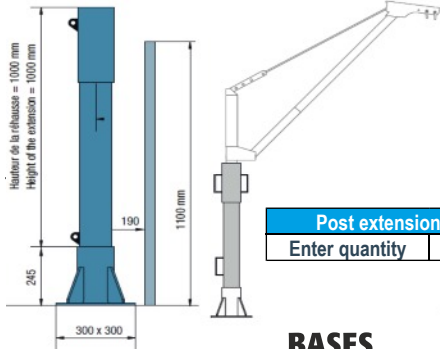

Post extension

Enter quantity

CONFIGURATIONS

Base installation is the purchaser's responsibility, we recommend consulting a structural engineer or other qualified professional.

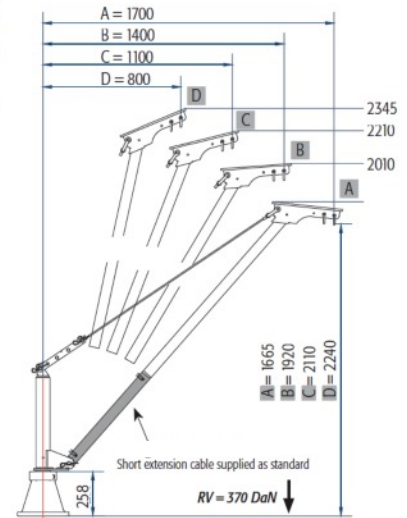
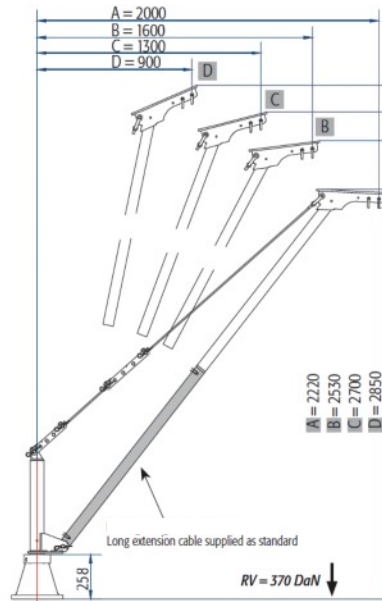

BASES

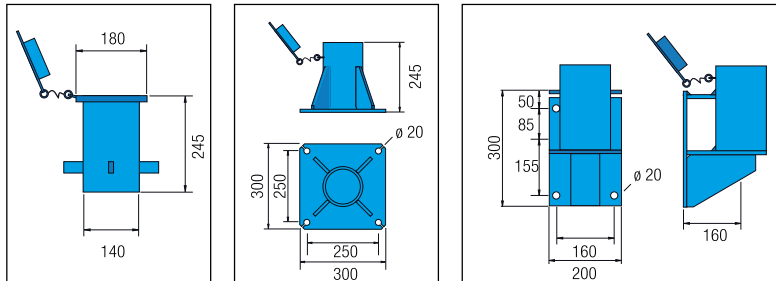

Cast-in Socket Base	Quantity	Surface Mounted Base	Quantity	Wall Mounted Base	Quantity
Galvanised (16 kg)		Galvanised (18 kg)		Galvanised (18 kg)	
Stainless steel (17 kg)		Stainless steel (18 kg)		Stainless steel (18 kg)	

NEED A QUOTE?

If you would like a quote, please fill out this request form.~ Complete, save and email to sales@dale-lifting.co.uk

Name	
Company	
Address	
Telephone No.	
Email address	
Notes	
Delivery address if different	

Optional Extras	Finish	Height of lift / length	Quantity
Index lift chain with latch hook	Galvanised	1.0 m	
	Stainless steel	1.0 m	
Pump lifting chain with ring every metre	Galvanised		
	Stainless steel		
Dee shackle (Screw Pin)	Galvanised		
	Stainless steel		
Hand chain block	Standard		
	Corrosion resistant		
Yale 360 hand chain hoist with rotating hand wheel guard allows offset operation	Standard		
	Corrosion resistant		
Delta electric chain hoist 110V	Standard		
Delta electric chain hoist 240V	Standard		
Lodestar electric chain hoist 110V	Standard		
Lodestar electric chain hoist 240V	Standard		



DALE

Lifting and Handling Specialists
 2 Kelbrook Road
 Manchester M11 2QA
 Telephone 0161 223 1990
 Email sales@dale-lifting.co.uk
 Website www.dlhonline.co.uk