

PAA 150 / 1.3

STEEL LIFTING DAVIT CRANE

dlhonline.co.uk - 0161 223 1990

These removable jib cranes can be used in all industrial fields; lifting of pumps in wastewater treatment plants, installation of tools or heavy loads on machine tools; round ; milling machines; maintenance operation on motor or geared motor indoors or outdoors.

PAA's can be equipped with the lifting device of your choice; manual cable winch or range of manual hoists, electric chain hoists and load handlers.

Completely removable, you can transport it from one workstation to another thanks to the installation of ground bases or wall bases previously installed.



PAA 150 / 1.3

STEEL LIFTING DAVIT CRANE

dlhonline.co.uk - 0161 223 1990

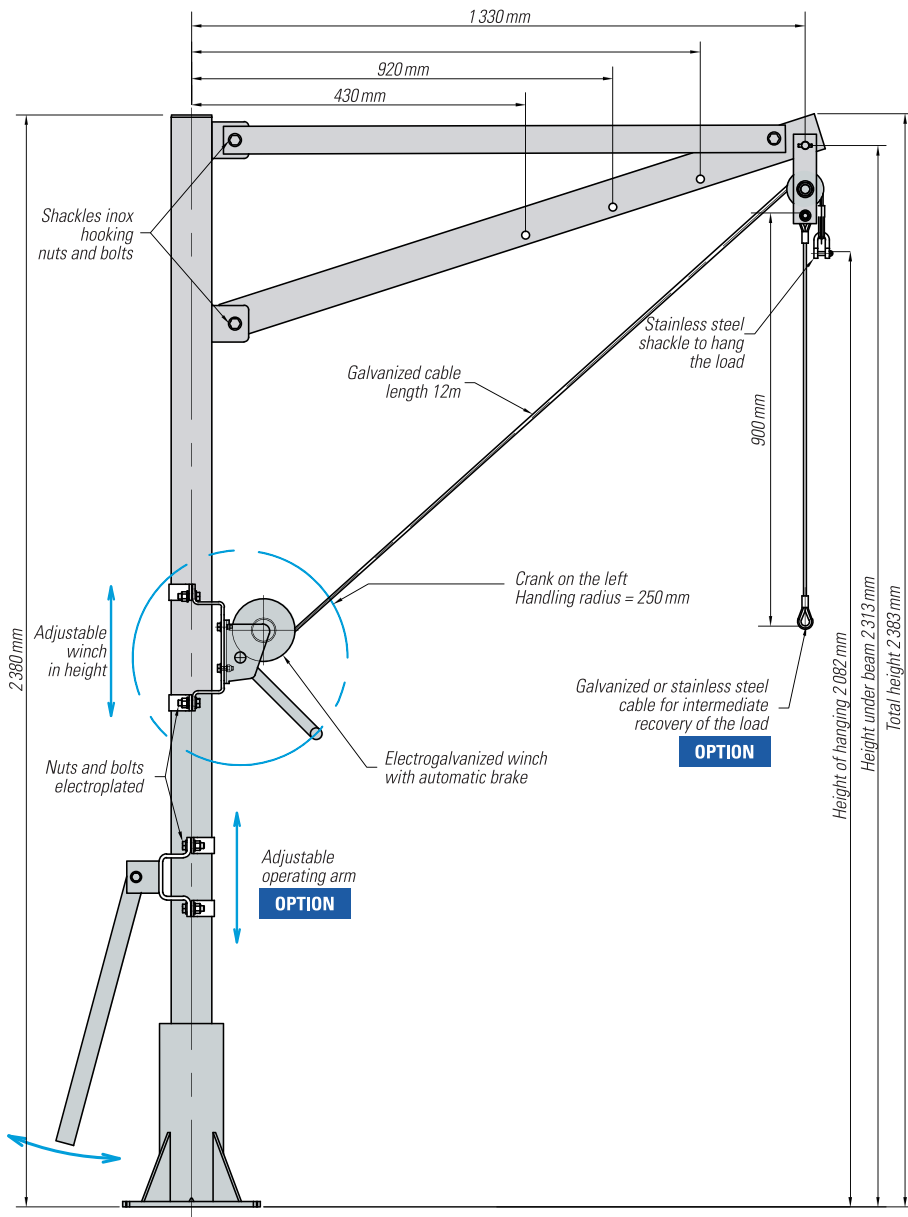

Measure in mm

Span	430	920	1110	1330
HA	1863	1936	2009	2082
HSF	2094	2167	2240	2313

Weight in Kg

Pillar	22
Deflection	17
Winch	13
Operating arm	6
Chemical socket	15
Wall socket	12

Socket for ground

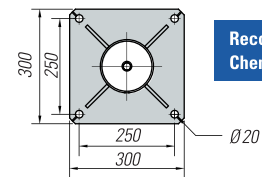
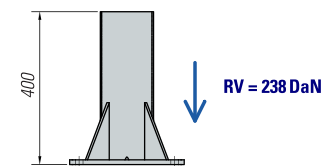

Socket for wall

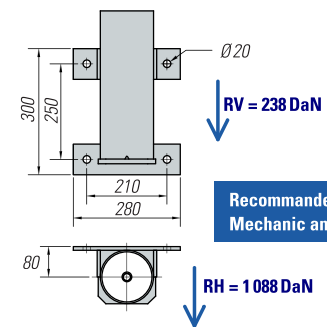

Description

- Galvanised finish / Socket galvanised and painted.
- SWL = 150 DaN.
- Adjustable span from 730 mm to 13300 mm.
- Height of hooking at the shackle = 2082 mm.
- Standard version with manual winch electro-galvanised
- Galvanised cable length 12 m:
- automatic load brake,
- length per turn of the handle = 39 mm,
- storage capacity = 23m / Ø cable = 4 mm,
- crank force = 72 N.

Options

- Rotation arm.
- Bolts, winch and operating arms Stainless steel.
- Winch rope in stainless steel.
- Galvanised or stainless steel intermediate sling.

Davit only version without winch with suspension for:

- manual hoist
- electric hoist
- Air balancer
- Tool balancer

- Stainless steel pulley mounted on bearing.
- Stainless steel shackle for long load attachment. 12 mm.
- Maximum moment = 272 DaN.m
- Reaction per anchor = 495 DaN.

PAA 150 / 1.3

STEEL LIFTING DAVIT CRANE

dlhonline.co.uk - 0161 223 1990

NEED A QUOTE?

If you would like a quote, please fill out this request form.~
Complete, save and email to sales@dale-lifting.co.uk

Name	
Company	
Address	
Telephone No.	
Email address	
Notes	
Delivery address if different	

Select PAA 150 / 1.3 Options	Quantity Required
Davit only	
Davit with Galvanised winch, 12 m rope and pulley	
Davit with stainless steel winch, 12 m rope and pulley	

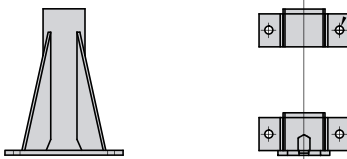
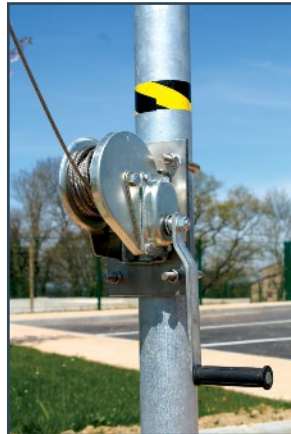

Select PAA 150 / 1.3 Sockets	Quantity Required
Surface sockets	
Wall sockets	

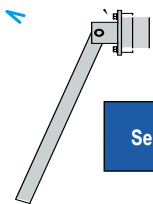

Select Rotational arm	Quantity Required

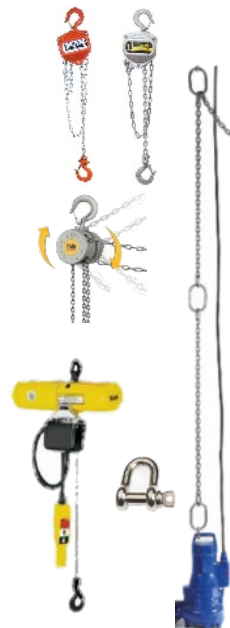

Optional Extras	Finish	Height of lift / length	Quantity Required
Intermediate cable sling	Galvanised	0.9 m	
	Stainless steel	0.9 m	
Pump lifting chain with ring every metre	Galvanised		
	Stainless steel		
Extra Dee shackle (Screw Pin)	Galvanised		
	Stainless steel		
WH Hand chain block	Standard		
	Corrosion resistant		
Yale 360 chain block with rotating guard, allows offset operation	Standard		
	Corrosion resistant		
Yale CPS electric chain hoist 110V	Standard		
Yale CPS electric chain hoist 240V	Standard		
Air balancer	Standard		
Tool balancer	Standard		

Additional information / requirements

DALE

Lifting and Handling Specialists
2 Kelbrook Road
Manchester M11 2QA
Telephone 0161 223 1990
Email sales@dale-lifting.co.uk
Website www.dlhonline.co.uk