

SPECIFY YOUR CUSTOM PALLET GATE

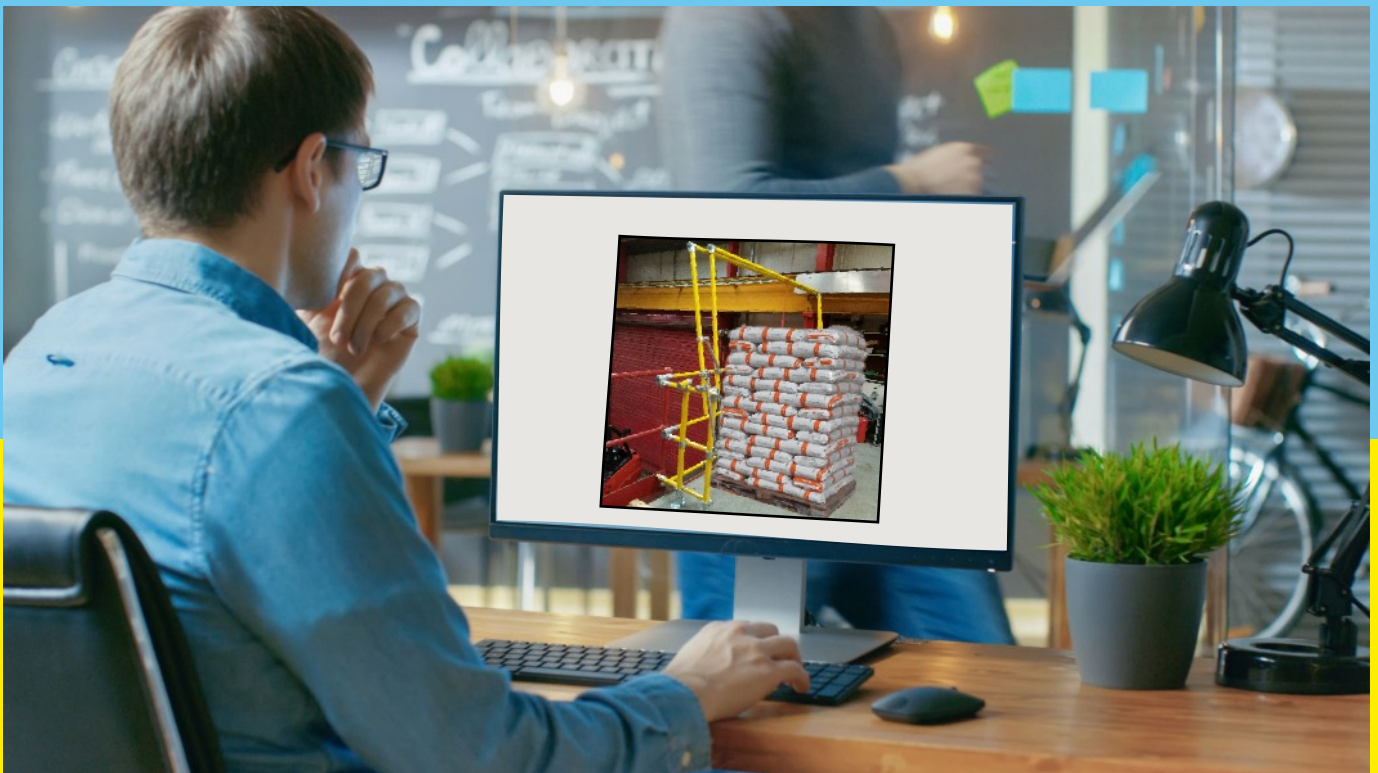

Sigma



MEZZBARRIERS

Mezz Barriers is a division of Dale Lifting and Handling Specialists
2 Kelbrook Road, Parkhouse Street Industrial Estate, Manchester, M11 2QA
Telephone 0161 223 1990 Email mezzbarriers@dale-lifting.co.uk

Need a Custom Pallet Gates for your exact dimensions or special application?

There are numerous standard designs of pallet gates on the market; however, some of these devices may not be suitable for your specific application and location. You may want to consider a gate system specifically designed to meet your needs. Guardrail openings and high-level doorways are constructed and function differently, a specific design of an all round protection safety gate may be needed for your situation, one size does not fit all!

No Problem - Tell us where your safety pallet gate is to be used?

Please select the nearest situation to your actual location. Don't worry if the proportions are not as your actual layout, You can upload a sketch, drawing or photo if required. We can discuss finer details once we have your quote request.

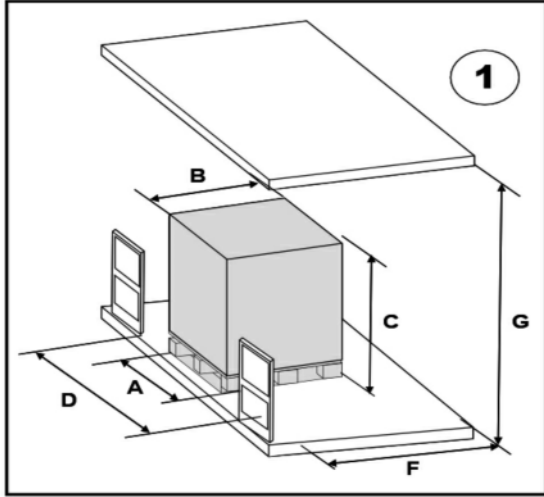

1. Loading by forklift to a mezzanine or platform

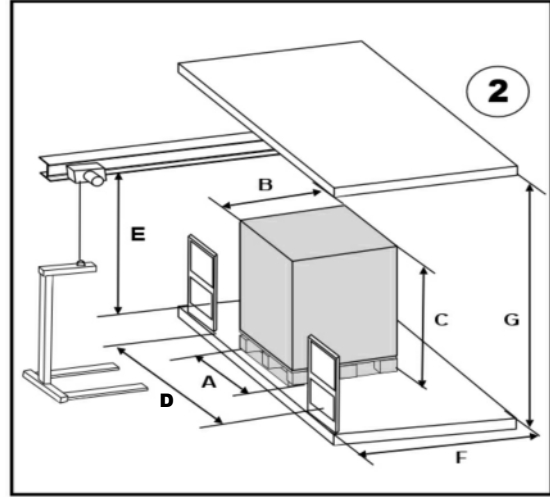

2. Loading by hoist to a mezzanine or platform

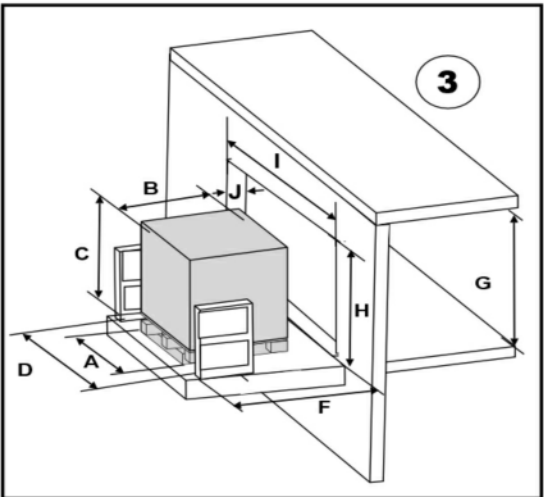

3. Loading onto a balcony with an opening or doorway

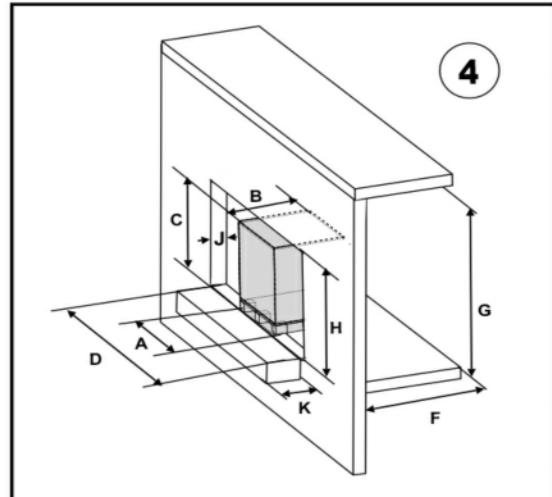

4. Loading through an opening or doorway, If the opening has a runway beam (See fig.2) tell us the height to underside of beam E.

NEED A QUOTE?

If you would like a quote, please fill out this request form.~ Complete, save and email to sales@dale-lifting.co.uk

First choose your location (See panels above)

TIPS - Please select the nearest situation to your actual location. Don't worry if these proportions are not as your actual layout, If you can attach a sketch, drawing or photo it with help us. We can discuss finer details once we have your quote request with dimensions. Put an X in any irrelevant key dimensions boxes. Still not sure? Give us a call on 0161 223 1990 for expert advice. We will do our best to provide the ideal solution for your site.

Number of gates required

Select finish required

Key Dimensions we will require for your quote (mm)

A. Pallet or load width	<input type="text"/>	G. Headroom or ceiling height	<input type="text"/>
B. Pallet or load depth	<input type="text"/>	H. Height of opening	<input type="text"/>
C. Pallet or load height	<input type="text"/>	I. Width of opening or doorway	<input type="text"/>
D. Opening width (Gap if present)	<input type="text"/>	J. Wall thickness	<input type="text"/>
E. Height to underside of the runway beam	<input type="text"/>	K. Depth of the ledge	<input type="text"/>
F. Operational depth available	<input type="text"/>	Type of doors if fitted Dropdown box	

Name	<input type="text"/>
Company	<input type="text"/>
Address	<input type="text"/>
Telephone No.	<input type="text"/>
Email address	<input type="text"/>
Notes	<input type="text"/>
Delivery address if different	<input type="text"/>

Why do I need a double gate system?

To secure the areas in which material is to be loaded and unloaded in your facility, a double pallet gate system is vital for your employee's safety as it protect the edge at all times.

Why not just have an edge gate?

Because swing gates, trombone gates, removable bars or chains (Which can flip the worker) can only guard the edge when shut and are routinely left open. These are accidents waiting to happen! Even fall protection safety harnesses are ineffective, as they only protect the wearer, if they remember to put it on!

Who says we have to use a double gate system?

You will need to make sure you comply with **HSE** and other safety professional's guidelines. Your gate system should be in conformance with **BS EN ISO 14122-3:2016** for Mezzanine Gates. The standard requires that a double or dual gate system is a **must have**. "As this will create an **always guarded** loading area". These safety experts say that this type of safety gate must always be used to secure the loading area. Only an enclosed gate system will ensure that all employees will be safely protected from moving loads and falling injuries during the loading process. And, at all other times too!

The Mezzbarriers range includes 9 innovative designs

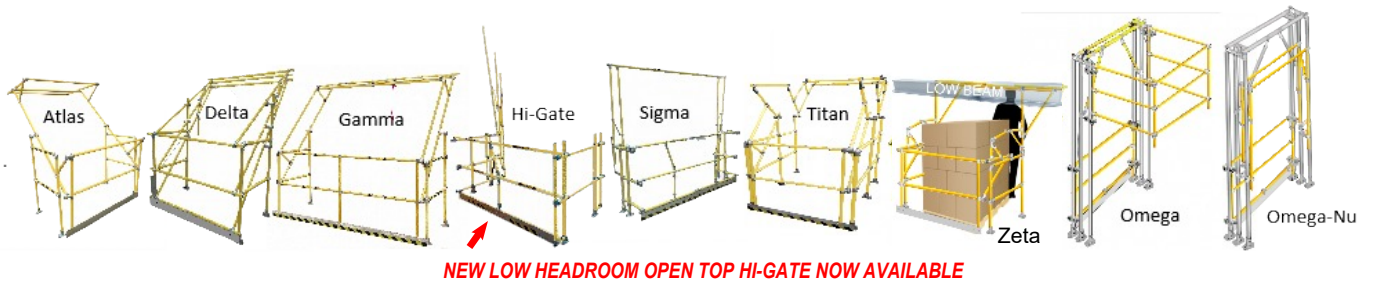

Utilising one our basic designs we will adapt it to exactly suit your specific application.



We will supply an approval layout with dimensions with your custom pallet gate no-obligation quotation. Plus installation and safe use instructions with your new gate. And, with our mechanical construction system, all parts are replaceable ensuring durability in use.

What our customer's are saying

“ Very impressed - I'm sure we will do business again in the future. Jim Muir CRC Ltd

“ We have fitted the gate and it works extremely well. Adrian Tonks Chief Engineer DENSO



For more information please read our blog post - [Pallet Gates - Frequently Asked Questions](#)

Or visit our Mezzbarriers [case study pages](#) for more ideas on finding the right solution for you.

Need more help? **Call 0161 223 1990** to ask to talk to an expert to guide you through the process or email: mezzbarriers@dale-lifting.co.uk