

flexicrane



LIFTING WITH FLEXICRANE

Lifts All is one of the world's leading manufacturers of lifting tools. Our wide product range supplies industries all over the globe with custom-made ergonomic solutions. We lift all!

DLHONLINE.CO.UK

Ceiling mounted



FLEXICRANE 2 M

The multifaceted FlexiCrane follows you wherever you go - smoothly and silently!

A liftsystem for Your workplace

FlexiCrane is mounted with a steel pillar on the wall, in the ceiling or on the floor, depending on the design of the workplace. The length of the pillar is customised. There is always enough space for a FlexiCrane with a tailor-made gripper!

Easy installation

Thanks to the light weight design and the handy size FlexiCrane is easily installed in no time and therefore at a low cost.

Super ergonomic handling solution

The low weight of the crane combined with low-friction bearings makes .Using Lifts All lifting aids does not only save backs, but also time and money.

Energy effective air hoist

Since the crane is driven by compressed air, costs are even saved during the very use of FlexiCrane. Our standby mode costs nothing!

The endlessly rotating crane

Another nice feature about FlexiCrane is that due to the clever design of air intake, the arm can actually rotate, not only a full turn - but endlessly!

GENERAL DATA

Max load: 65 kg

Range: 4 m Rotation: Unlimited

Size of pillar base: 37x37 cm

Driven by: Compr. air 6-7 bar Laquered: Red (RAL 3020)



Floor mounted

Pillar length: 50-250 cm
Weight example: 62 kg (250 cm pillar)
Art. no: 95-10113 or 95-10251



Wall mounted

Pillar length: 50-100 cm
Art. no: 95-10114 or 95-10113



Ceiling mounted

Pillar length: 15-200 cm
Art. no: 95-10114



Mounted in crane system

Art. no: 95-10256

MEASUREMENTS (mm)

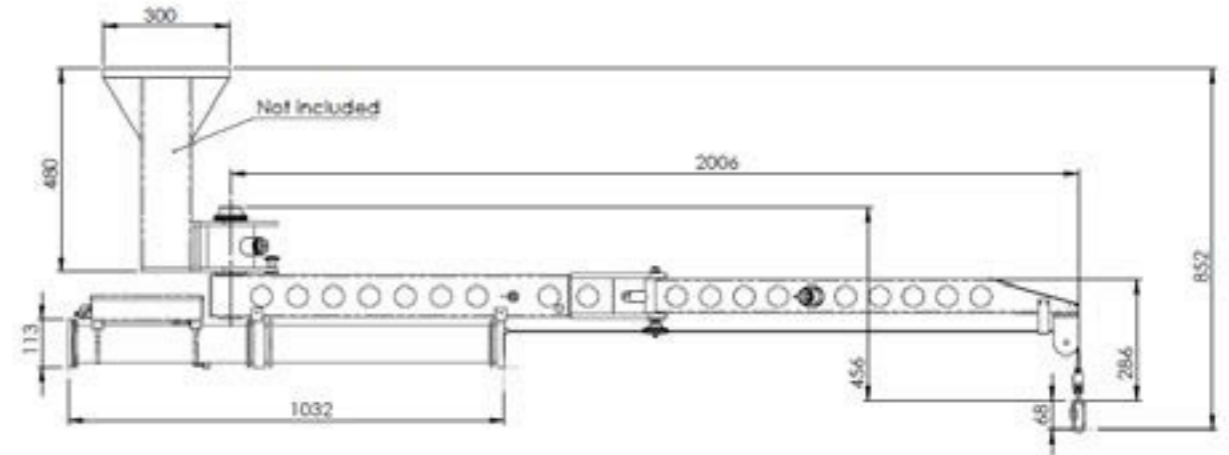

RANGE (mm)

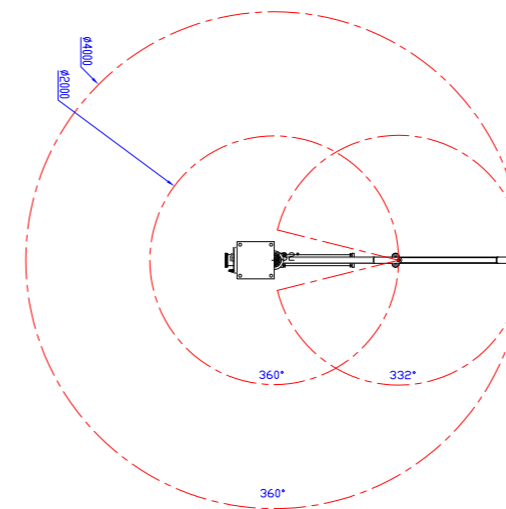

MEASUREMENTS CROSS MOUNTED IN CRANE SYSTEM (mm)

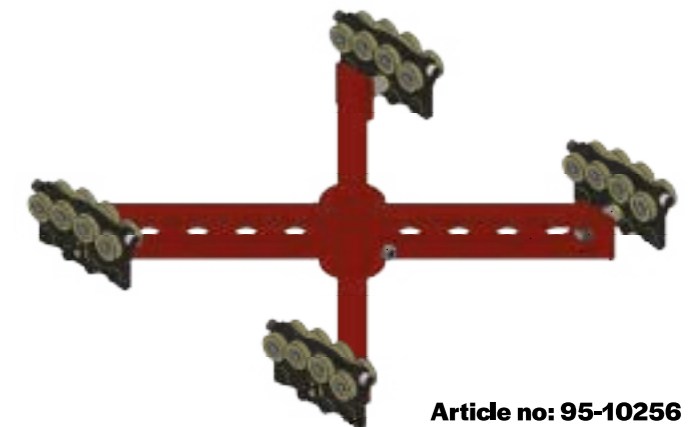
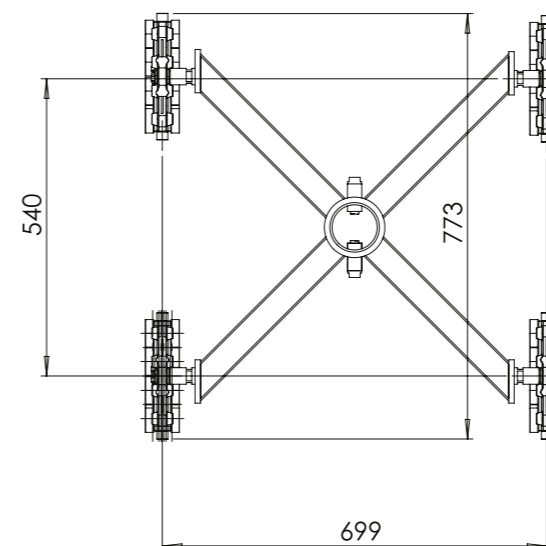

Article no: 95-10256



Adjustable floor pillar

The pillar is adjustable in height at installation between 2,1-3,4 m. The inner pillar is drilled and bolted at the desired height.

Article no: 95-10251



STAINLESS STEEL CRANE

FlexiCrane is available in an electroplated stainless steel version as a new standard. It is smooth and easy to clean and can be used in sensitive environments, such as pharmaceutical or food processing industries.

Article no: 95-10258

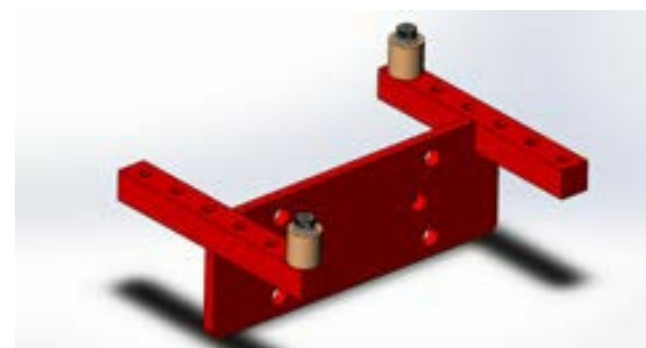

ROTO-STOP

Roto-Stop prevents unwanted movements of the inner Flexi-Crane arm. The angle can be limited within +/- 63 degrees up to +/- 130 degrees.

Article no: 95-10274

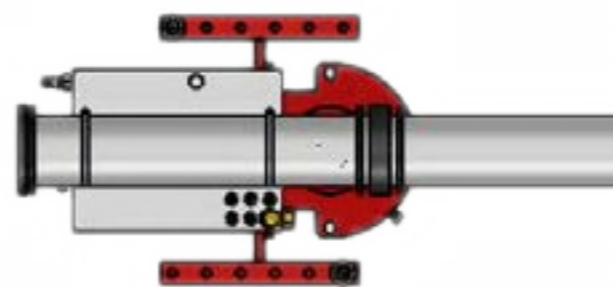
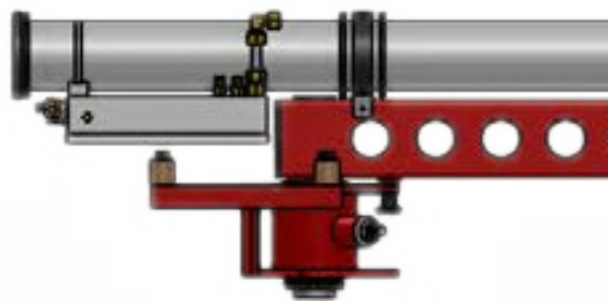

GENERAL DATA

Max load: 65 kg
Range: 4 m Rotation:
Unlimited

Total weight: 450 kg (excl. gripper)
Size of pillar base: Ø1,49 m.
Height: 2,15-2,75m (fixed pillar max 3 m)
Driven by: Compressed air 6-7 bar
Laquered: Red (RAL 3020)

TRANSPORT MODE

Total weight: 450 kg
(Bal-Trol, crane arm, pillar and pillar base)
Length: 177 cm
Width: 149 cm
Height: 215 cm

FLEXICRANE MOBILE 2 M

The latest version of FlexiCrane is the portable articulated jib crane you have always been looking for. It is just as smooth and silent as the original but with a moveable base, free from attachments to the floor and - of course - still safe and stable during lifting.

Two-step-installation

To install the crane:

1. Put it down on the floor.
2. Plug in the air supply.

Done! The FlexiCrane is now ready to lift whatever you wish up to 65 kg.

Adaptable to different work stations

The movability of FlexiCrane Mobile creates opportunities for the whole workplace. Adjust the height with the pneumatic switch and you are ready to lift in spaces with low headroom as well as up to that shelf. Complete the integrated Bal-Trol hoist with a hook for your buckets, a vacuum lifter for the carton boxes or why not a mechanical gripper to lift and tilt rolls?

MOVING THE CRANE

Moving FlexiCrane Mobile is as simple as installing: Drive down the pillar to the bottom, unplug the air supply, fold the articulated slewing arm and secure it with a strap. Grab a pallet truck and get moving to the next workstation! The convenient size of FlexiCrane also makes it easy to send by truck without having to disassemble (and later reassemble) the whole crane.



Watch it moving on
[youtube.com/LiftsAll!](https://www.youtube.com/LiftsAll!)

Spider Platform

Article no: 95-10297

An adjustable and movable base, the Spider Platform enables a crane to be moved by pallet truck to navigate through narrow doorways, along corridors and in confined areas.

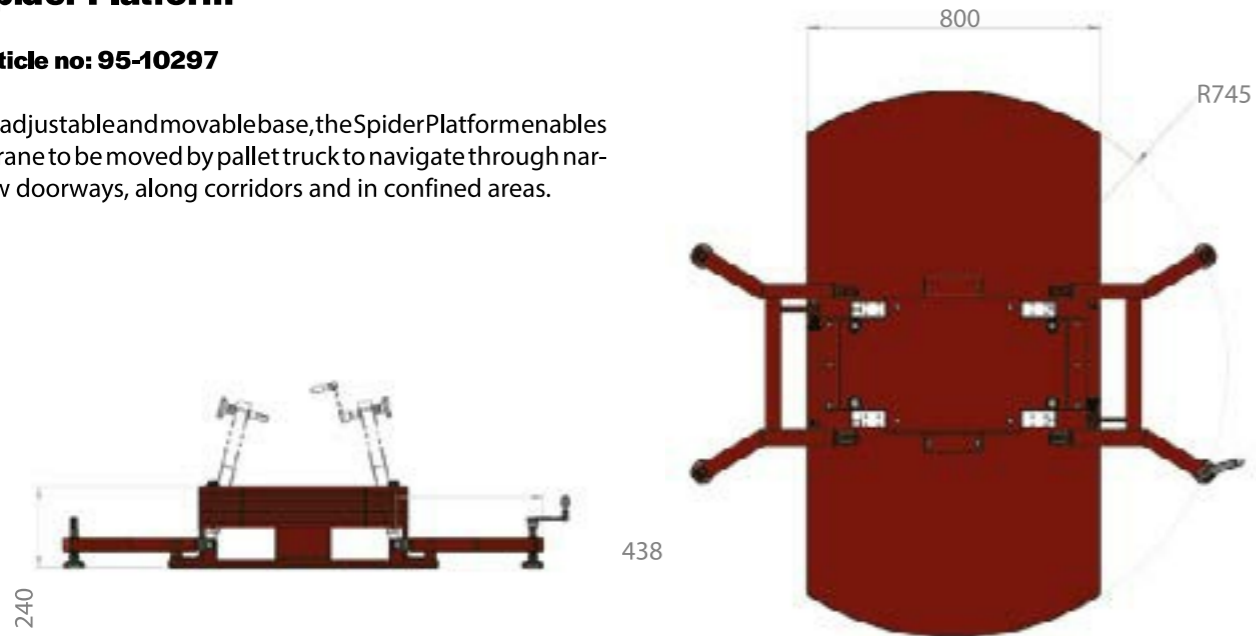

Mobile platform - 40kg

Article no: 95-10300

Our cranes can be secured onto a moveable base, which enables the crane to be moved by a pallet truck. This applies primarily to FlexiCrane and FlexiCrane 3m, but a tailored jib crane can also be adapted to include a mobile base.

To move the crane, insert the forks of the forklift or pallet truck in the holes at the base of the crane. Lift and move to a suitable location, where the floor/ground is absolutely horizontal.

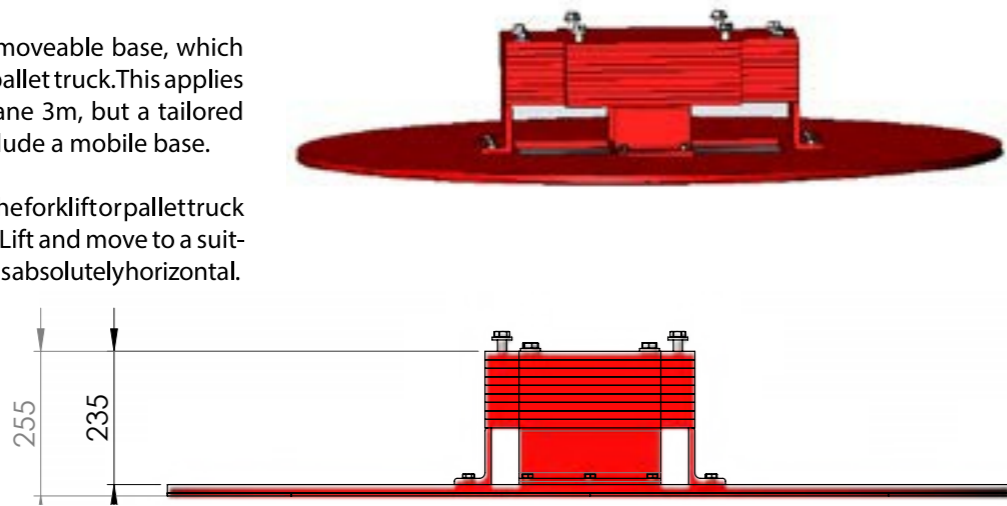

Article no: 95-10300

Our mobile platform is also offered with a two-part bottom plate for efficient transportation. This enables the platform to be easily maneuvered into tighter spaces.



MEASUREMENTS (mm)

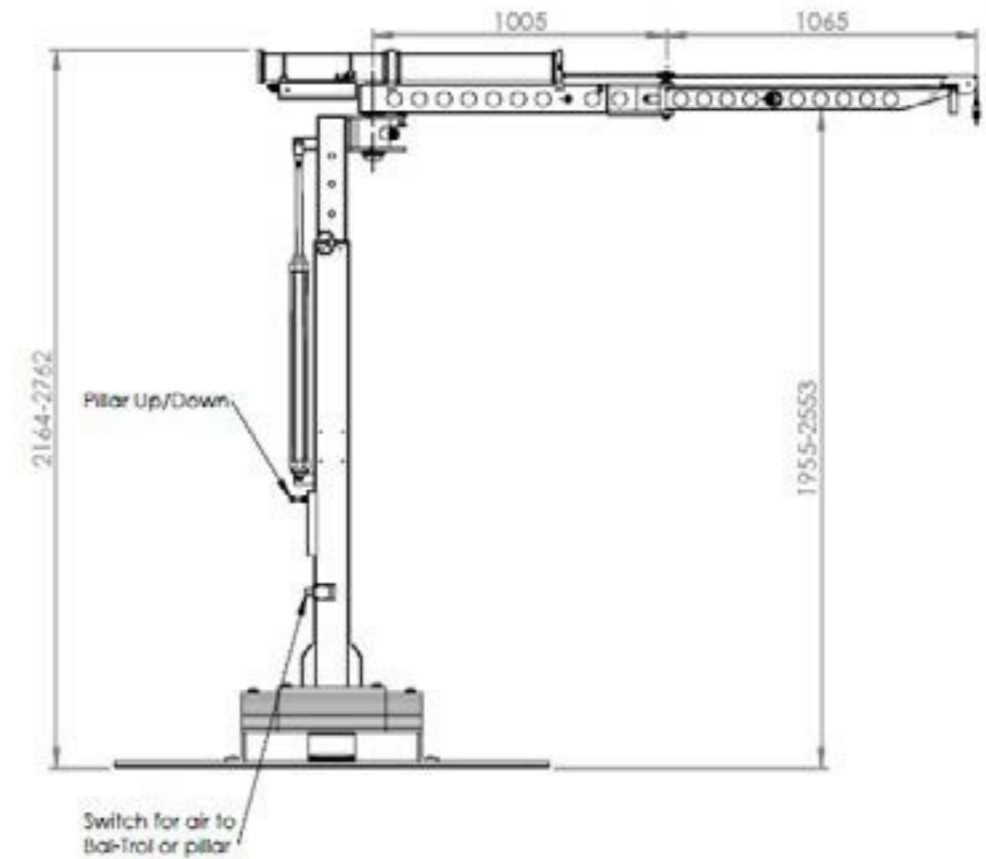

Article no: 95-10287

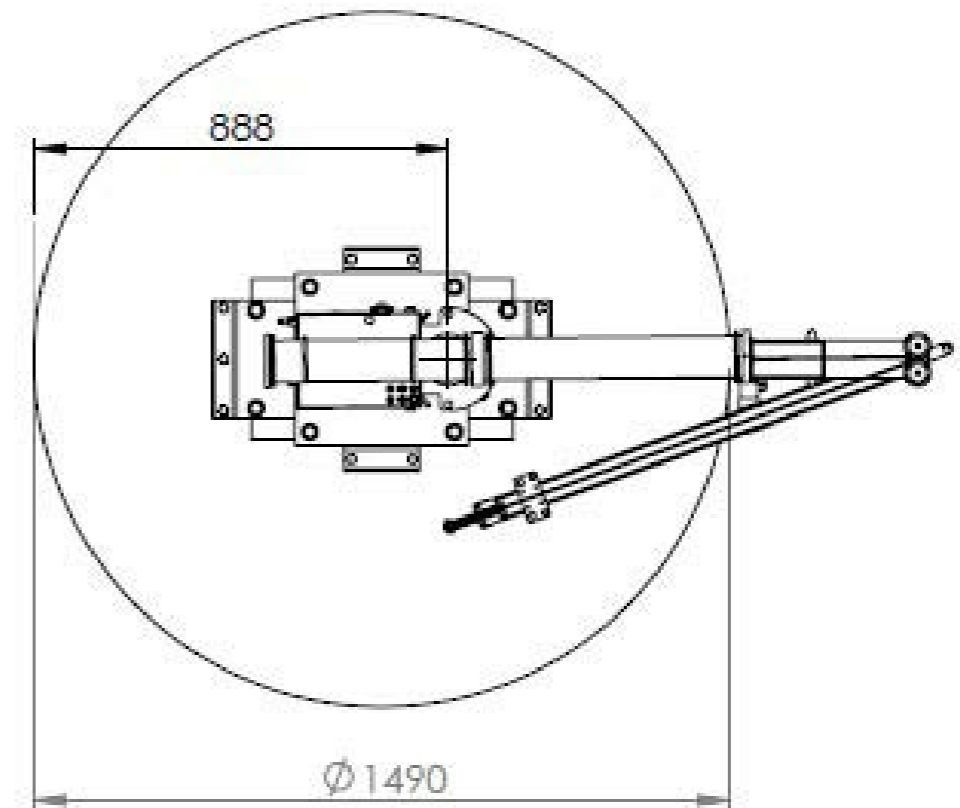

FLEXICRANE 3 M

The new Flexi Crane arm reaches three meters around its pillar. The outer arm can be mounted above the inner arm for low head spaces or under the inner arm for free rotation.

GENERAL DATA

Max load fixed pillar: 65 kg	Rotation outer arm: Unlimited
Max load Mobile: 50 kg	Driven by: Compr. air 6-7 bar
Range: 6 m	Laquered: Red (RAL 3020) Art nr: 95-10289
Rotation: 210 degrees	



MEASUREMENTS (mm)

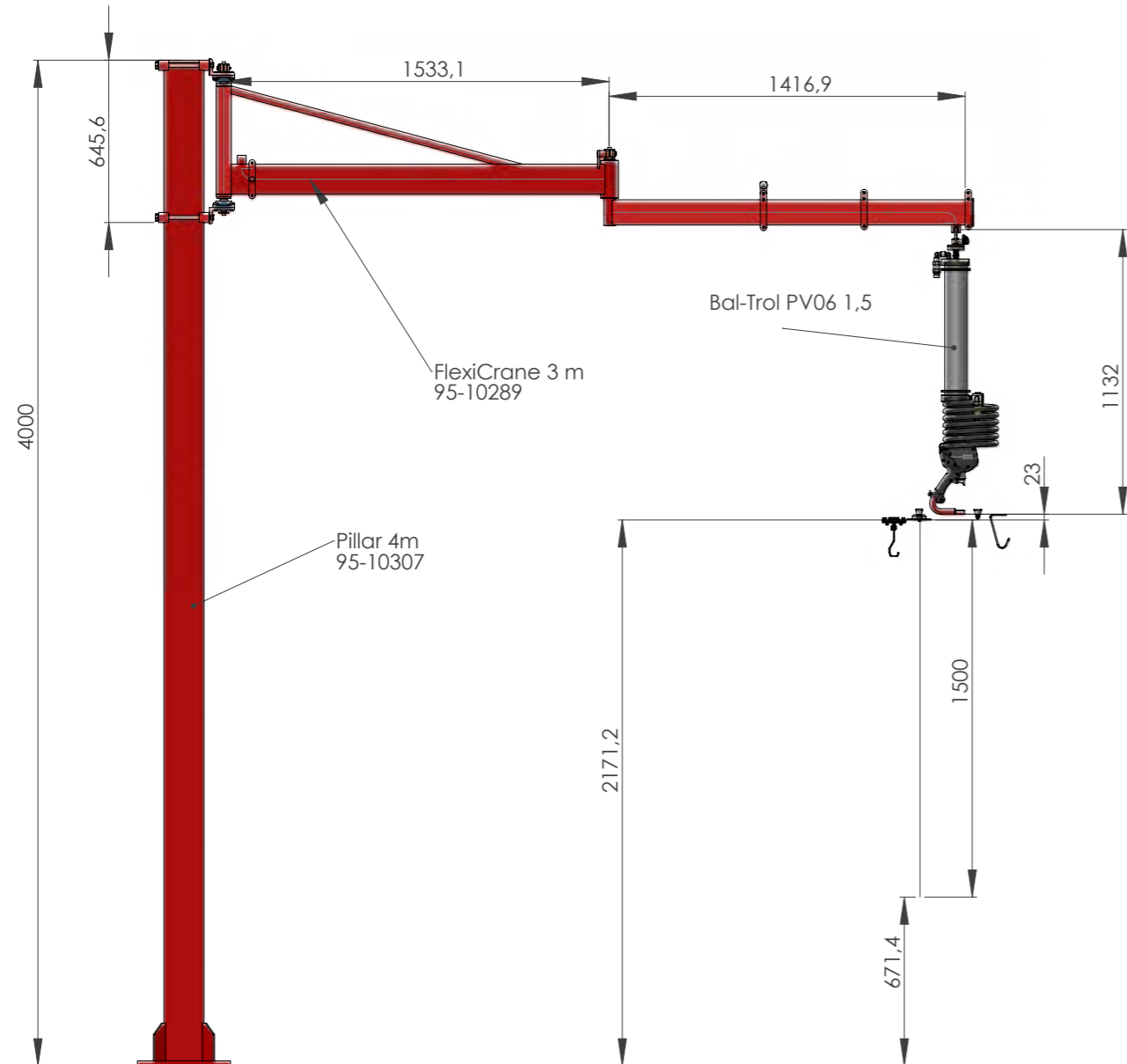

MEASUREMENTS (mm)

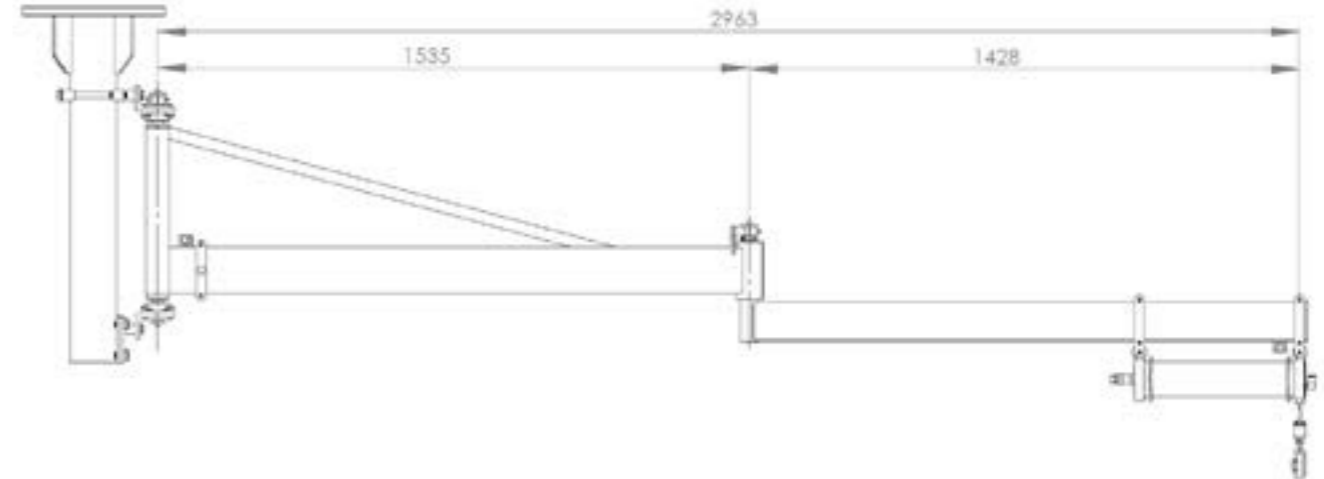

RANGE (mm)

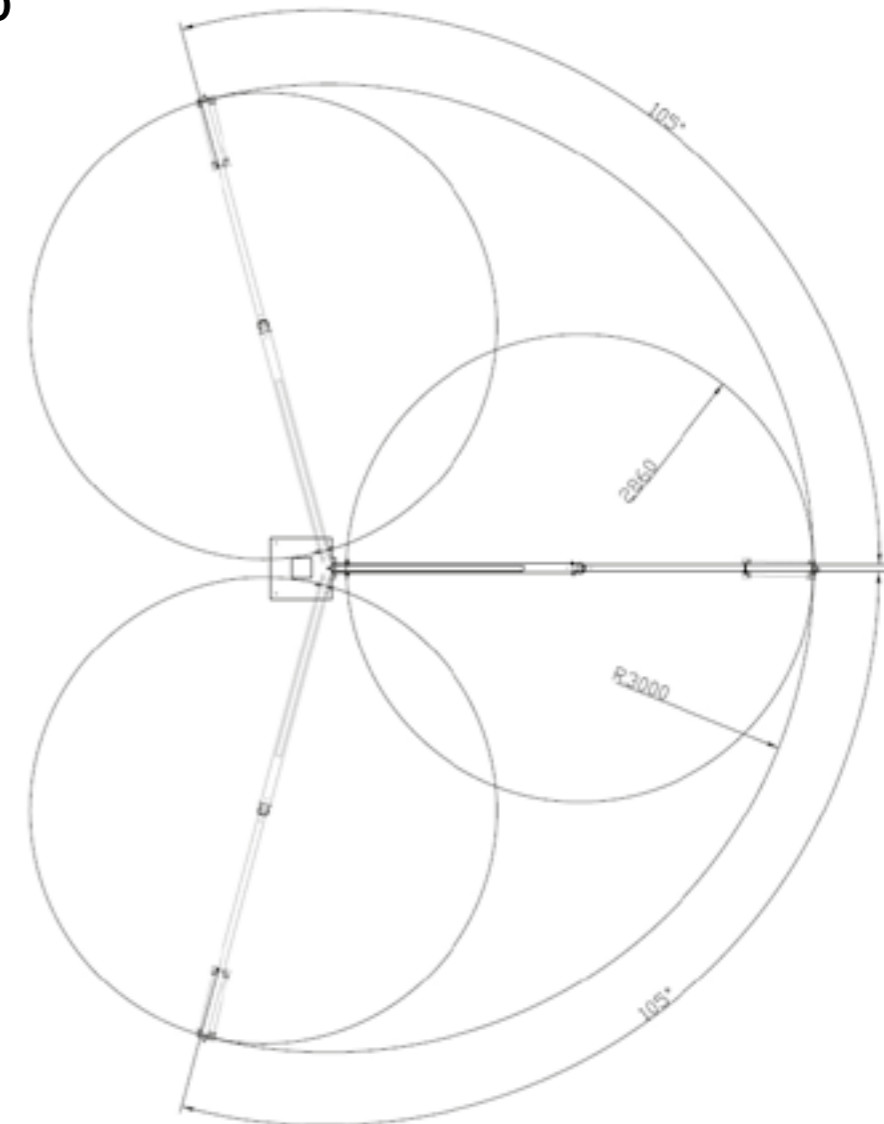

STANDARD PILLARS

These pillars are part of our standard collection. However, if you need different dimensions we can also customize pillars made to order. 160 x 160 x 6 mm.

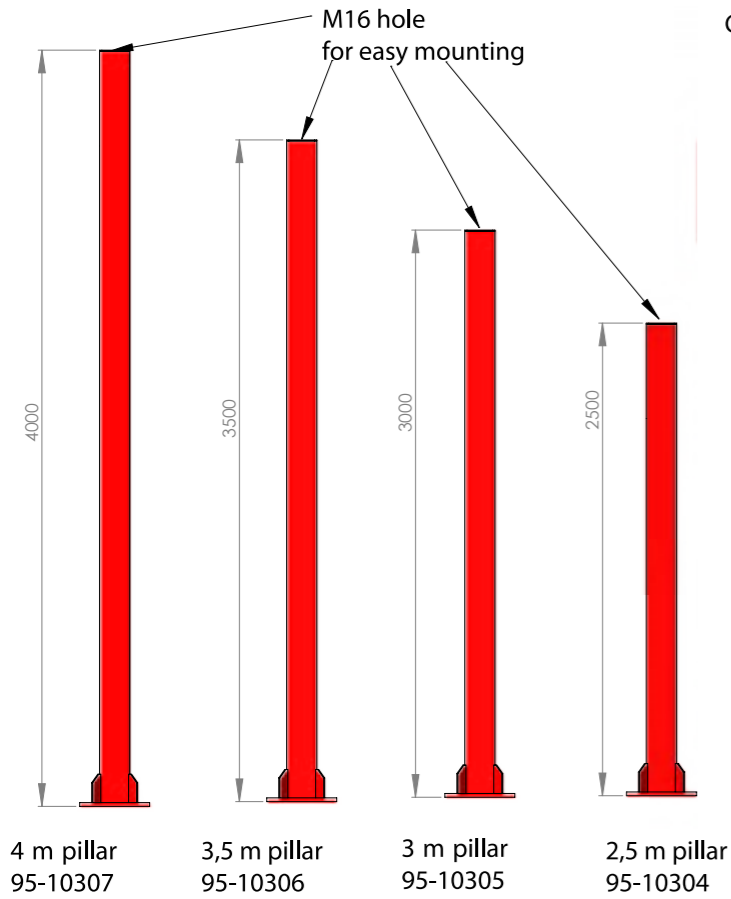

Clamping modules

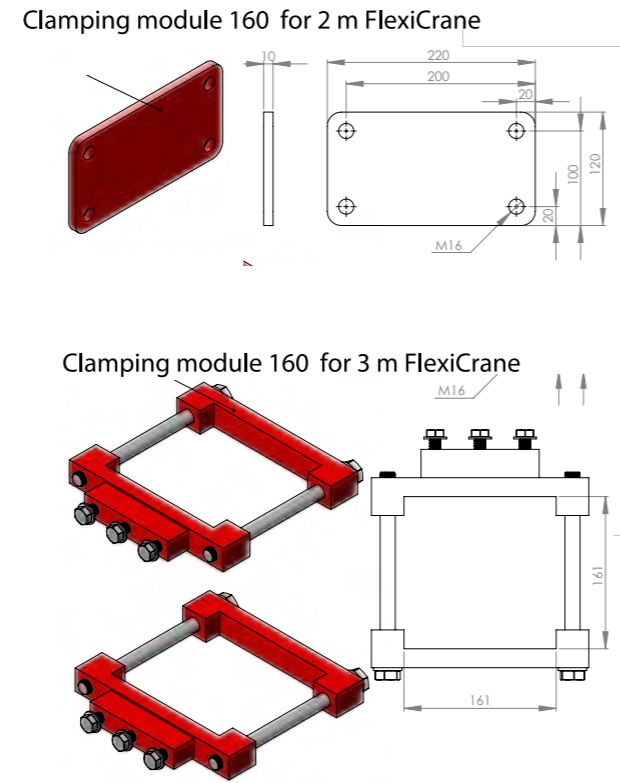

Bal-Trol-The small, flexible lifting cylinder is powered by compressed air only.

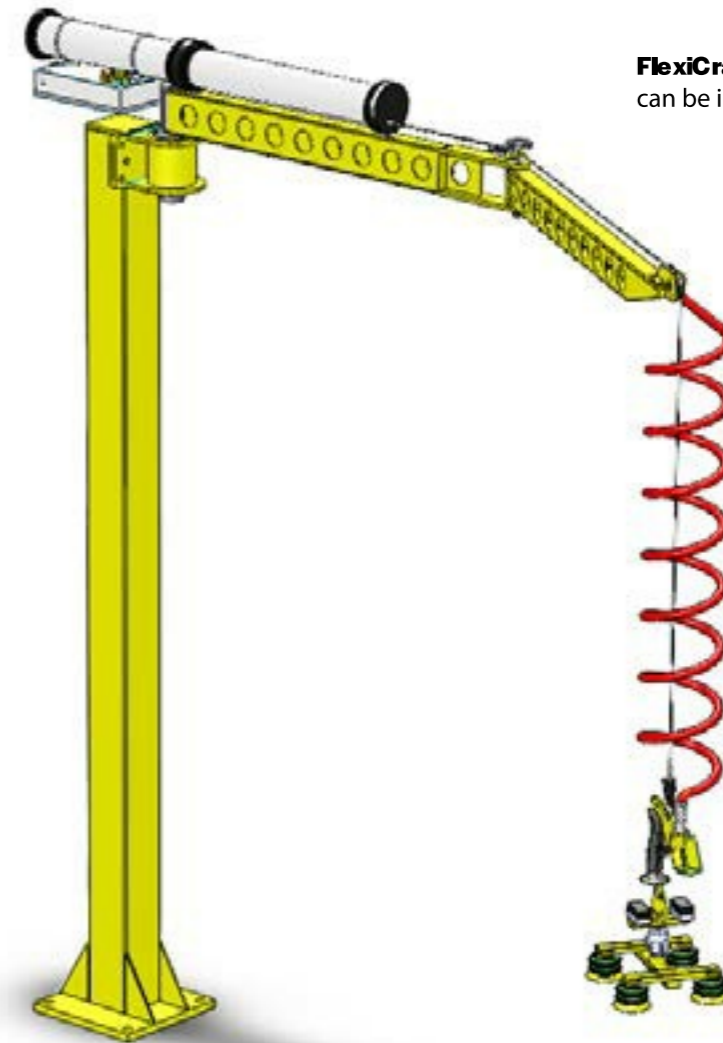

FlexiCrane -The multifaceted and smooth crane can be installed anywhere.

Gripper - Custom-made ergonomic grippers are our specialty. We lift all!



SAFE GRIPPER STORAGE

The storage pouch on the crane pillar is available to prevent the gripper from getting damaged during transport of the FlexiCrane Mobile.

Article no: 93-10060



PARKING FORK FOR BASIC

This parking accessory is handy when putting away the Basic unit and still easy to grab and get back to work again. The fingers are rubber covered. The holes in the plate are for 6 mm screws.

Article no: 93-10062

Maxicrane



LIFTING WITH MAXICRANE

Lifts All AB is one of the world's leading manufacturers of lifting tools. Our wide product range supplies industries all over the globe with custom-made ergonomic solutions. We lift all!

MAXICRANE

MaxiCrane is a rotating and smoothly moving crane with low weight. The handling of materials is fast and easy. The low-friction bearings makes MaxiCrane very silent and smooth to work with.

The crane is mounted with steel pillar on wall, ceiling or floor. As opposed to the FlexCrane, the MaxiCrane have greater capacity and handles heavier loads.

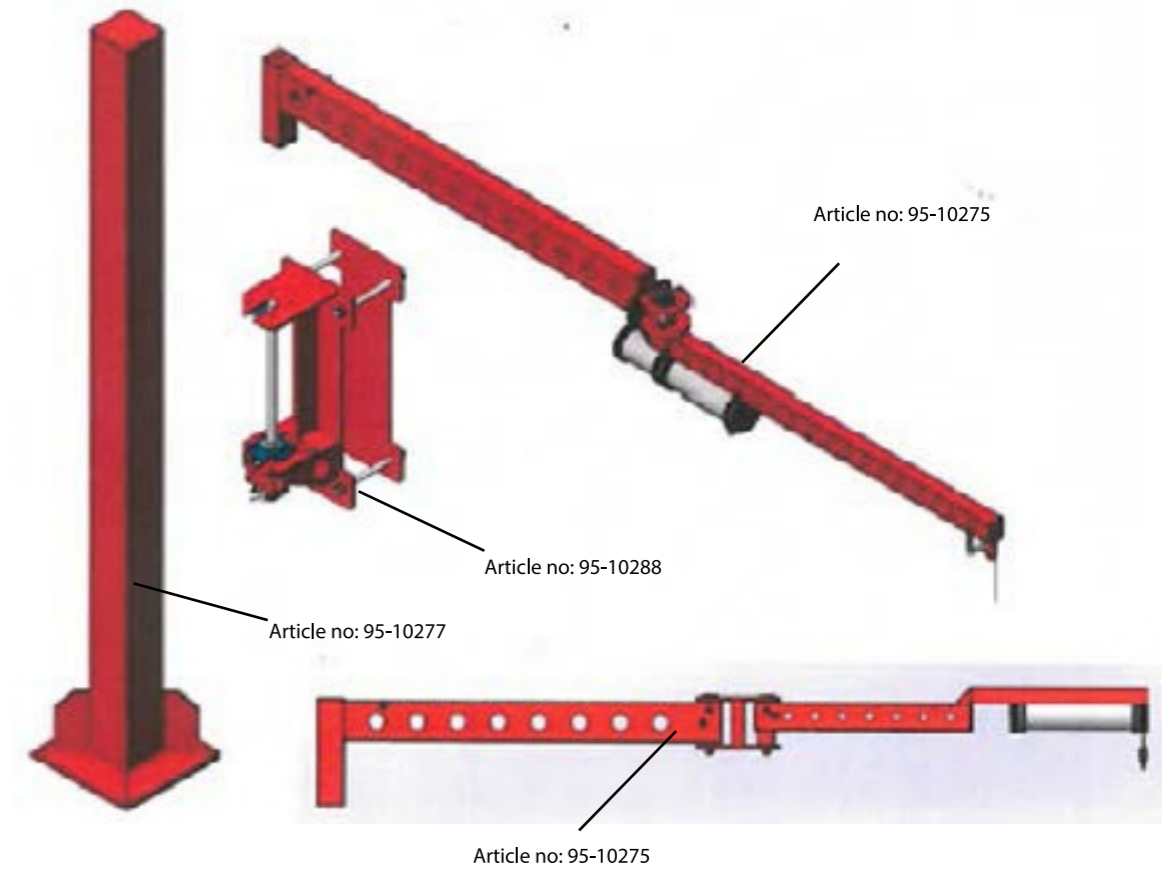
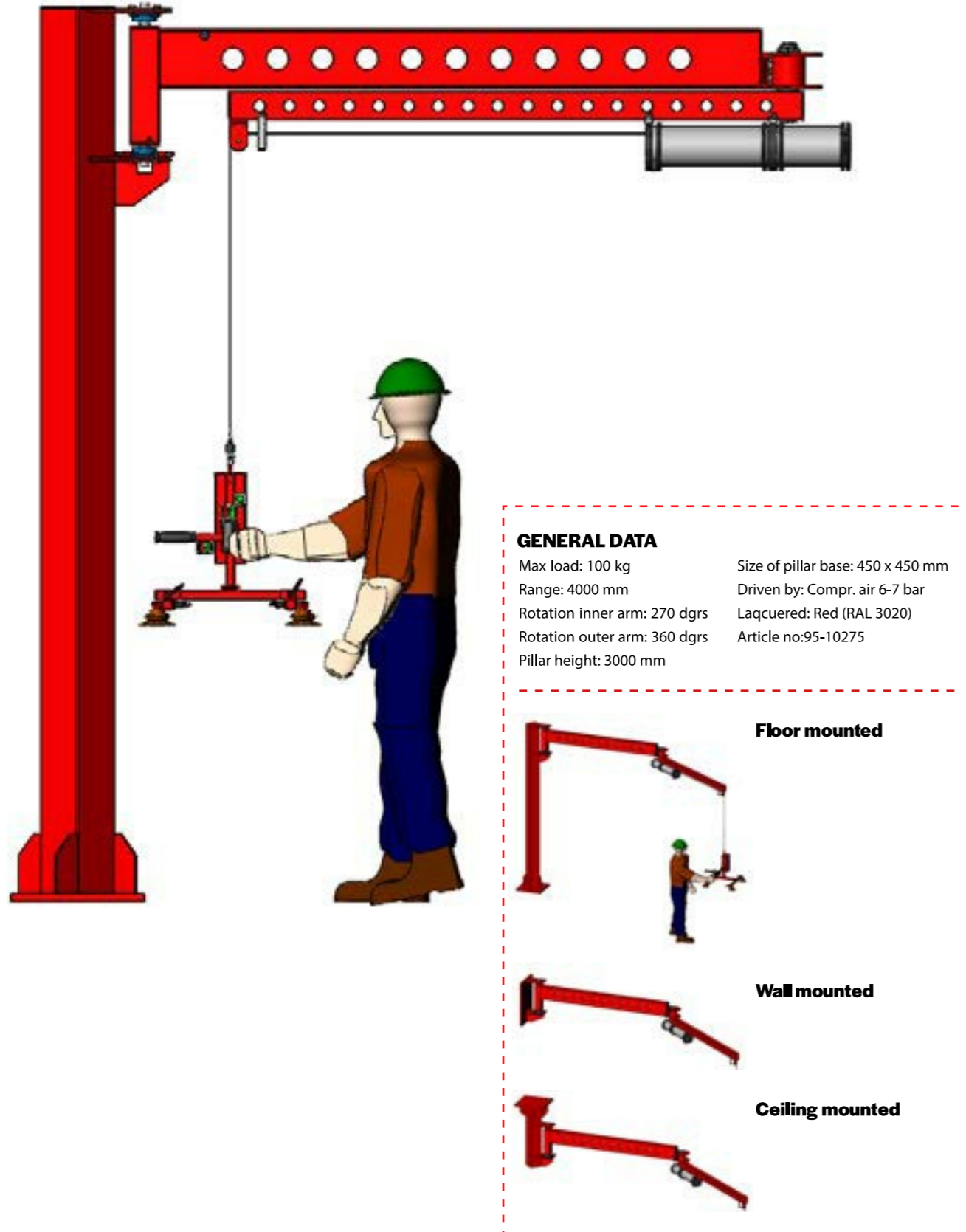

A lift system for Your workplace

MaxiCrane is mounted with a steel pillar on the wall, in the ceiling or on the floor, depending on the design of the workplace. The height of the pillar is 3 000 mm. There is always enough space for a MaxiCrane with a tailor-made gripper!

Easy installation

Thanks to the light weight design and the handy size MaxiCrane is easily installed in no time and therefore at a low cost.

Super ergonomic handling solution

The low weight of the crane combined with low-friction bearings makes it very silent and smooth to work with. Using LiftsAll lifting aids does not only save backs, but also time and money.

Energy effective air hoist

Since the crane is driven by compressed air, costs are even saved during the very use of MaxiCrane. Our standby mode costs nothing!

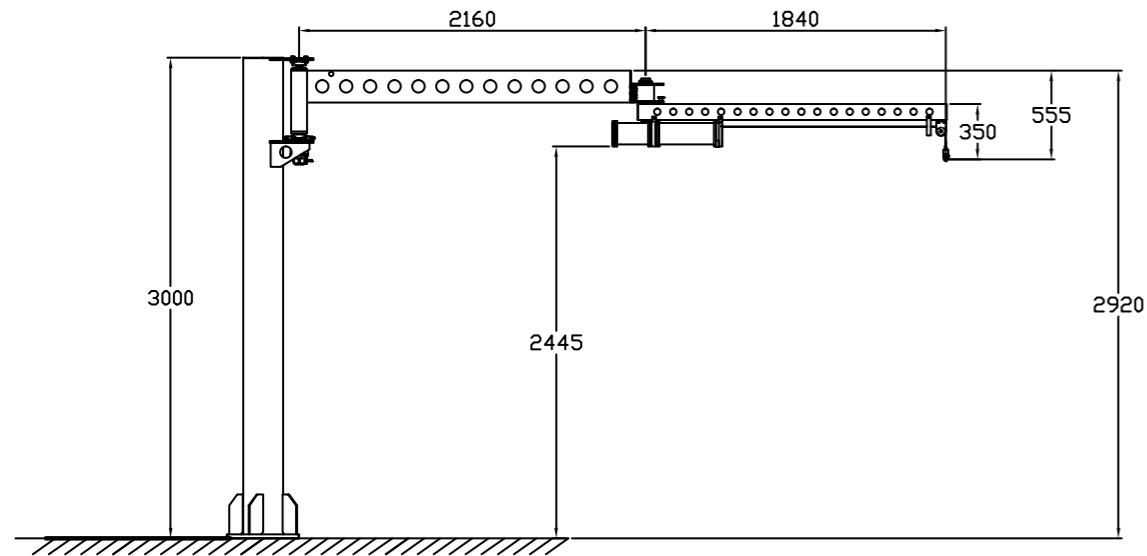
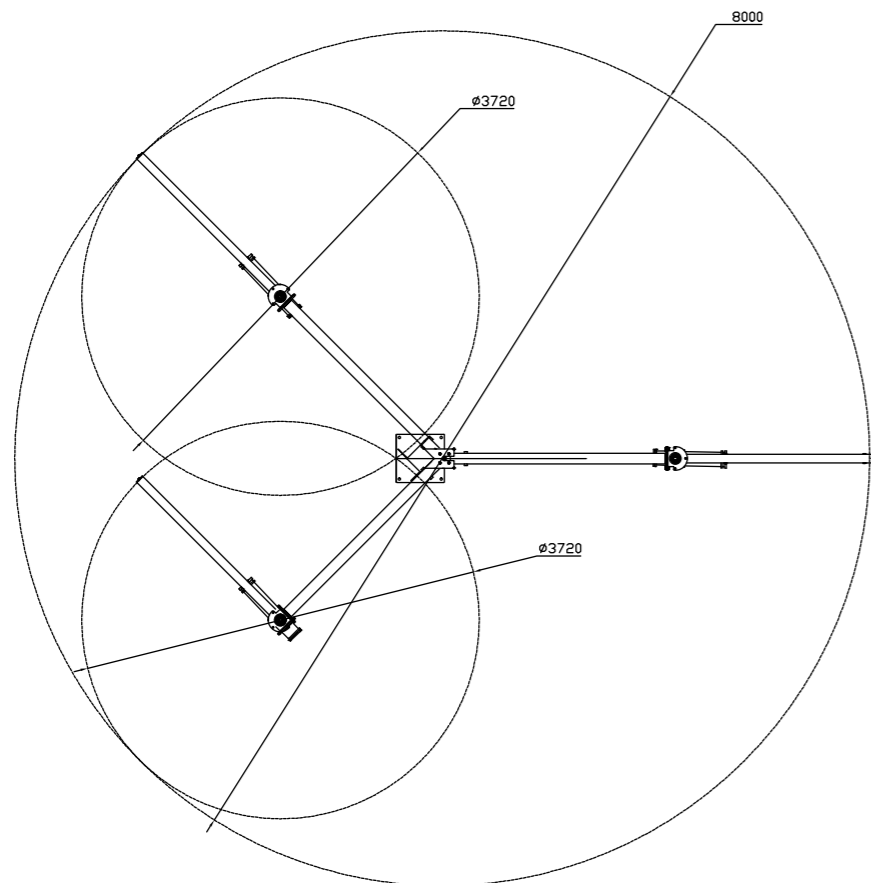
MEASUREMENTS FLOOR MOUNTED (mm)**RANGE FLOOR MOUNTED (mm)****MAXICRANE MINI**

MaxiCrane Mini is a rotating and smoothly moving crane with low weight. It can be adjusted in height by clamping on the standard pillar, but still has the same capacity of lifting 100 kg like the MaxiCrane. Thanks to the design of the outer arm, the head of the crane with the Bal-Trol is very low built.

**A liftsystem forYour workplace**

MaxiCrane Mini is mounted with a steel pillar on the floor. The height of the pillar is 3000 mm. The MaxiCrane Mini can be clamped by friction on the pillar at desired height.

Easy installation

Thanks to the light weight design and the handy size MaxiCrane Mini is easily installed in no time and therefore at a low cost.

Super ergonomic handling solution

The low weight of the crane combined with low-friction bearings makes it very silent and smooth to work with. Using LiftsAll lifting aids does not only save backs, but also time and money.

Energy effective air hoist

Since the crane is driven by compressed air, costs are even saved during the very use of MaxiCrane Mini. Our standby mode costs nothing!

GENERAL DATA

Max load: 100 kg
 Range: 3000 mm
 Rotation inner arm: 270 dgrs
 Rotation outer arm: 360 dgrs not free rotating
 Pillar height: 3000 mm
 Size of pillar base: 450 x 450 mm
 Driven by: Compr. air 6-7 bar
 Laquered: Red (RAL 3020)
 Article no: 95-10276

Adjustable in height, by clamping the MaxiCrane Mini on the standard pillar by friction.

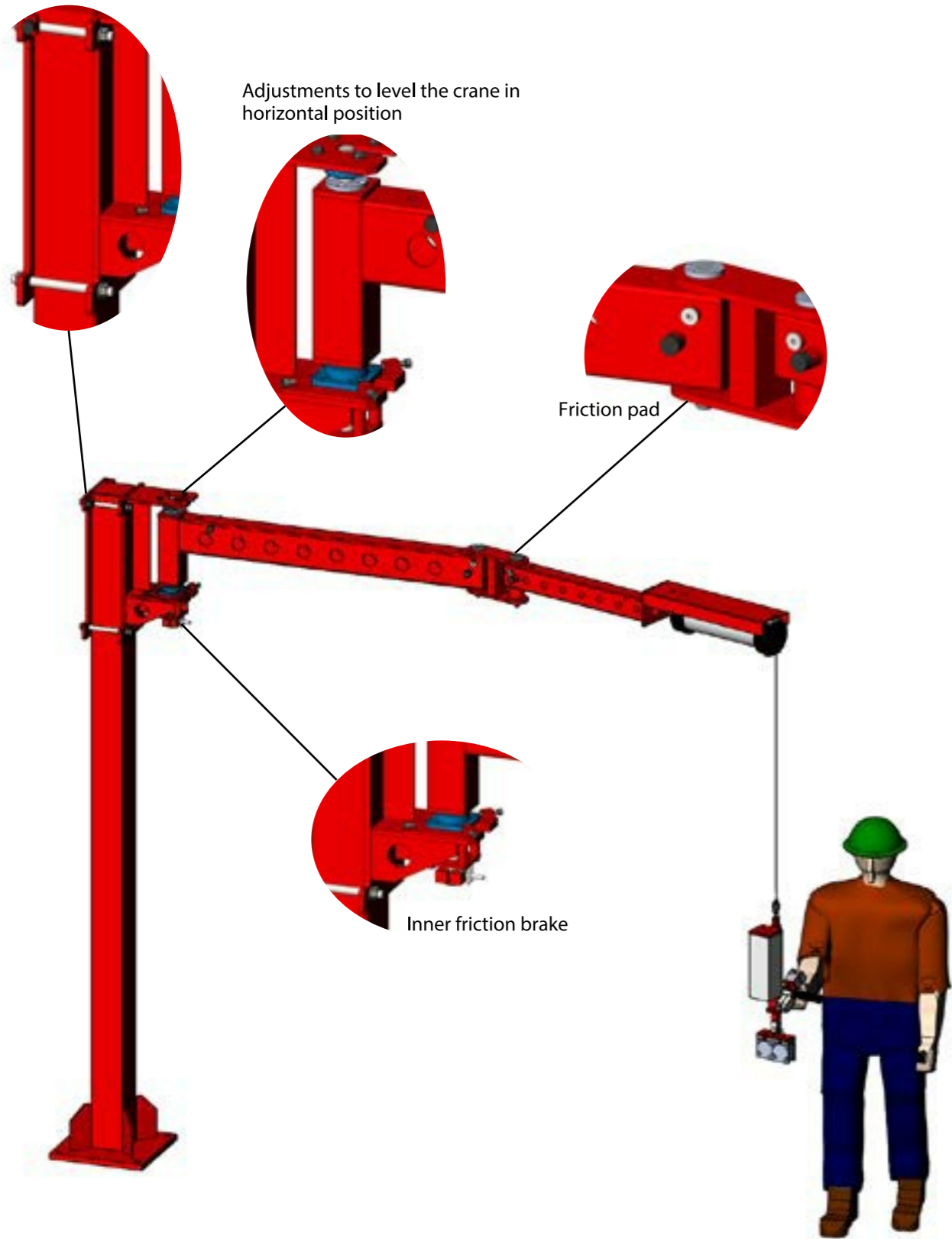

MEASUREMENTS FLOOR MOUNTED (mm)

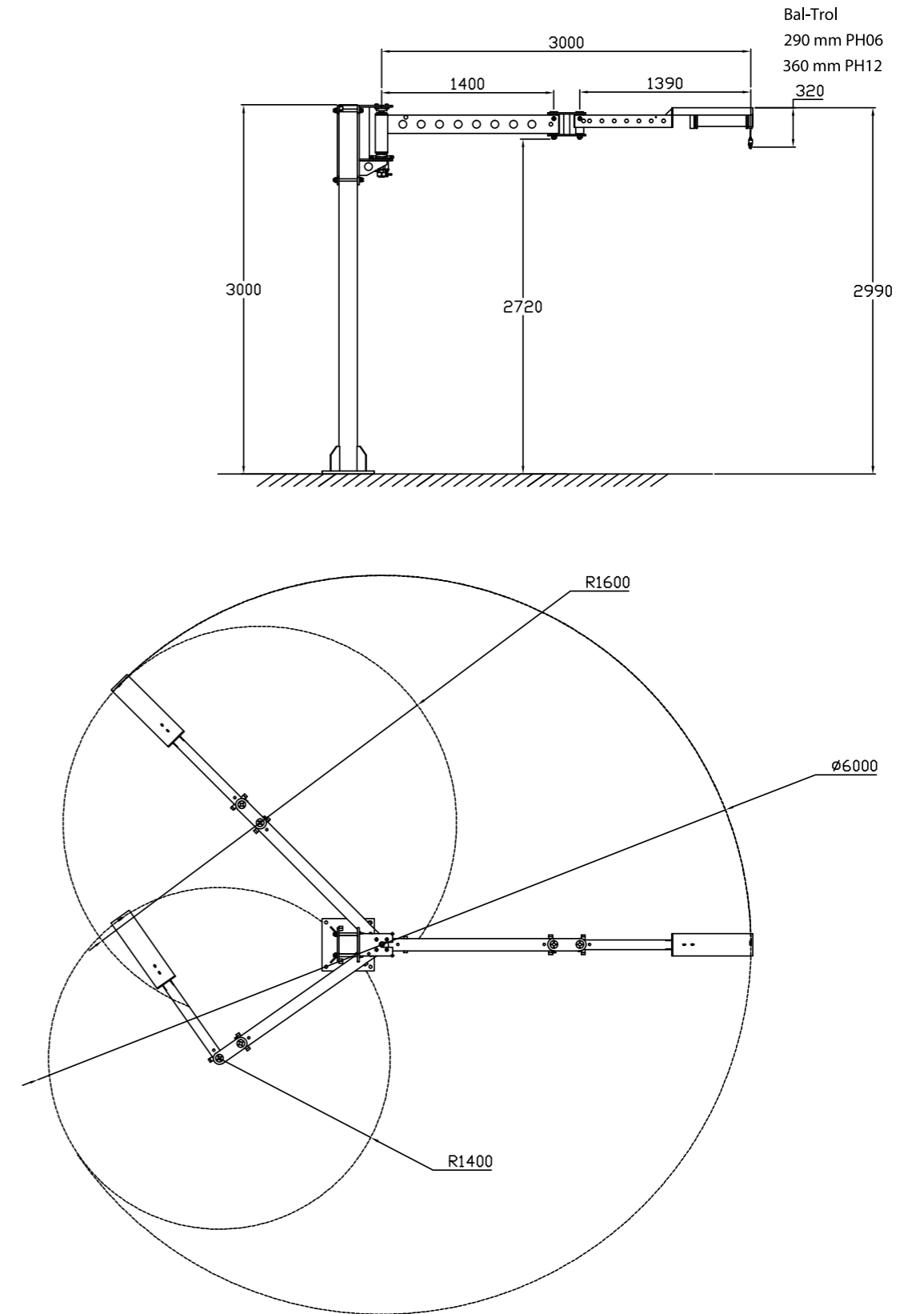

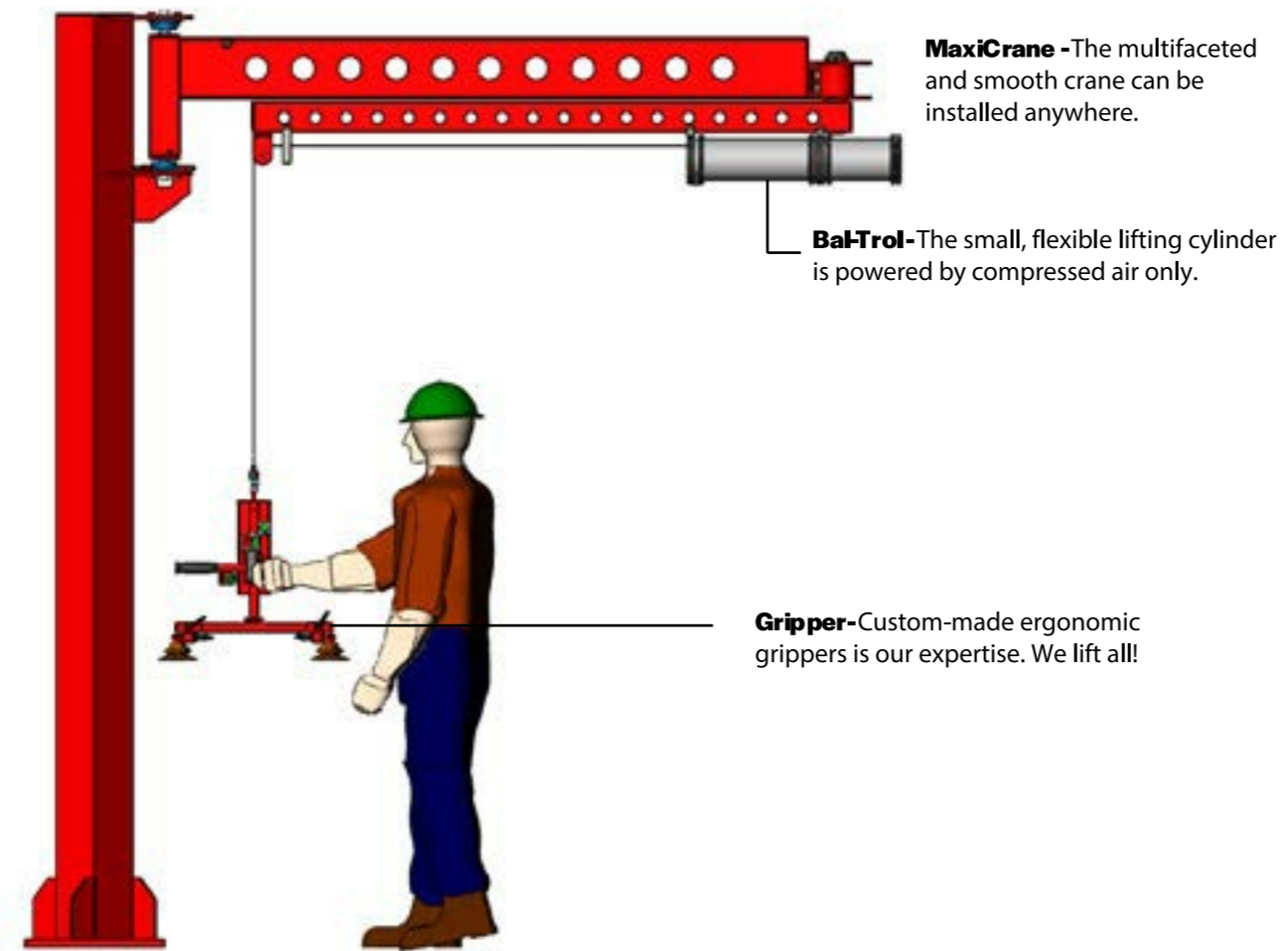

MaxiCrane - The multifaceted and smooth crane can be installed anywhere.

Bal-Trol - The small, flexible lifting cylinder is powered by compressed air only.

Gripper - Custom-made ergonomic grippers is our expertise. We lift all!

LIFTS ^{ALL} UK Main Agents
DALE Lifting and Handling Specialists
2, Kelbrook Road
Manchester M11 2QA
Telephone 0161223 1990
Email: sales@dale-lifting.co.uk
Website: dlhonline.co.uk