

## Tiger Lifting *Home of the Tiger hoisting range & Tiger subsea lifting products*

Tiger Lever Hoist Model No PROLH

### Main Features

- Now available with slipping clutch overload protection
- Range 800kg - 10.0t
- Equipped with our unique dual brake mechanism
- New twin pawl ratchet brake design allows for very fine adjustments on the lifting handle
- Light load tested and certified at 2% of the rated capacity
- Adaptable to use both inverted and horizontally
- Each hoist is individually proof tested at 1.5 times the rated capacity
- Using only the highest quality alloy calibrated load chains according to EN 818-7 and ISO 16872
- Lightweight and portable
- Individual spares readily available
- Operating temperature of - 40°C to + 50°C
- All major parts are heat treated and precisely machined
- Finished in high quality powder coat paint offering excellent corrosion protection
- Can be chained up to meet your exact requirements
- Also available with stainless steel load chain or spark resistant hooks
- Meets or exceeds all international standards



(with overload protection)

## Tiger Lifting *Home of the Tiger hoisting range & Tiger subsea lifting products*

### Tiger PROLH Lever Hoists

Lightweight, compact and rugged construction with the handle, gear case and brake cover made entirely of pressed steel, producing strong resistance to impact damage. Using only the highest quality materials precisely machined throughout ensures the PROLH is the ideal hoist for long term use with less maintenance and servicing costs. These units meet and exceed all the requirements within BS EN 13157: 2004+A1:2009, ANSI/ASME B30.21, AS1418.2 and SANS 1636.

### **Certification:**

Each unit comes fully certified with a test certificate or an EC Declaration of Conformity stating compliance with the essential health and safety requirements of the Machinery Directive 2006/42/EC. This document clearly states the proof test at 1.5 times the rated capacity and the light load test of 2% of the rated capacity, which exceeds the requirements of the current applicable standard.

### **Safety Brake:**

The PROLH comes equipped with our own unique dual brake mechanism that automatically engages when the lever hoist feels the slightest resistance on the bottom hook. This key feature means that the PROLH will raise, hold, and lower the lightest of loads without slipping. The two stage process protects against accidental light load failures caused by putting the hoist into neutral whilst under load. This latest development in brake efficiency guarantees permanent engagement of at least one of the twin reciprocating cam pawls fitted to the PROLH, ensuring the pawl only just clears the ratchet wheel, with the minimum of clearance as required under BS 4898:1973. The bonded friction discs are free of asbestos and achieve highly efficient braking.

### **Load Chains:**

Tiger only use the highest quality alloy, calibrated load chains in Grade 80 (T) or 100 (V) conforming to EN818-7 and ISO 16872. The PROLH comes as 1.5mtr HOL as standard but can be chained up to whatever length is required. Stainless steel load chain available on request for certain capacities.



## Tiger Lifting *Home of the Tiger hoisting range & Tiger subsea lifting products*

### Mechanical Efficiency:

All major components are heat treated and precisely machined to ensure long term smooth operation. High gear ratios keep physical effort to a minimum.



### Chain end stops:

User friendly heavy duty end stops make it easy for the operator to position the chain while "freewheeling", but most importantly this "end stop" will hold a load of at least 2.5 times the rated capacity when supporting the full load without restraint from other components e.g. brake or gearing.



### Chain stripper:

The new chain stripper is specifically designed to guide the load chain safely onto or off the load sheave without snagging or jamming. The fluted chain stripper allows the safe use of the PROLH when used in any orientation.



### Hooks:

Drop forged and heat treated alloy hooks are furnished with heavy duty latch kits that fully engage into the nose of the hook offering maximum load security. The swivel hooks are attached to the yoke using high grade nuts & socket head bolts allowing for complete inspection during any statutory inspection or written scheme maintenance. Also available with spark resistant hooks.



### Forgings:

Recessed forgings offer full protection to the load chain anchor bolts on all our bottom hooks.



## Tiger Lifting *Home of the Tiger hoisting range & Tiger subsea lifting products*

### Performance:

The PROLH lever hoist has undergone a full test program that includes:

#### Type Testing

- Ultimate strength test, at least 4 times the Working load limit (WLL)
- Chain end anchorage test, passing at least 4 times the WLL without any restriction of the brake or gears

#### Test on every hoist

- Proof loading at 1.5 times the rated capacity
- Light load testing at maximum of 2% rated capacity

### Grease:

High performance premium quality grease allows the PROLH hoists to be certified for use within a temperature range of -40°C to +50°C far exceeding the requirements of current standards.

### Finish:

The PROLH is finished in our high quality powder coat paint offering excellent corrosion protection.

### Technical Data

Product Code	Capacity (tonne)	Effort (kg)	Dimensions (mm)								Load Chain		Standard HOL (m)	Mass @ std HOL (kg)	Mass for extra metre HOL (kg)
			A	B	C	D	E	F	F1	F2	Diameter (mm)	No. of falls			
PLH-0075	0.8	23	128	240	275	158	99	33	28	44	■6.3	1	3	7.6	0.86
PLH-0150	1.5	26	154	360	320	172	104	38	34	48	■7.1	1	3	10.7	1.07
PLH-0300	3.0	38	182	360	400	195	108	40	35	54	■10.0	1	3	18.2	2.17
PLH-0600	6.0	40	242	360	570	195	108	54	50	68	■10.0	2	3	29.7	4.34
PLH-1000	10.0	47	370	360	630	195	108	60	54	90	■10.0	3	3	45.7	6.54

See page 6 for more hook information



Available with slipping clutch overload protection

### Technical Drawings

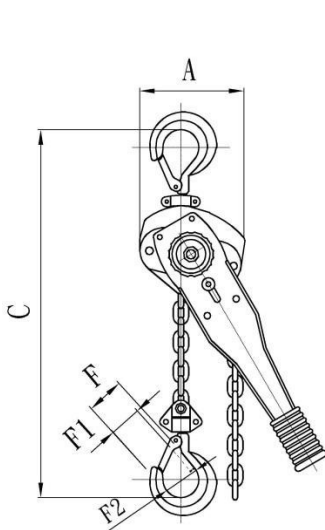

0.8t to 3.0t

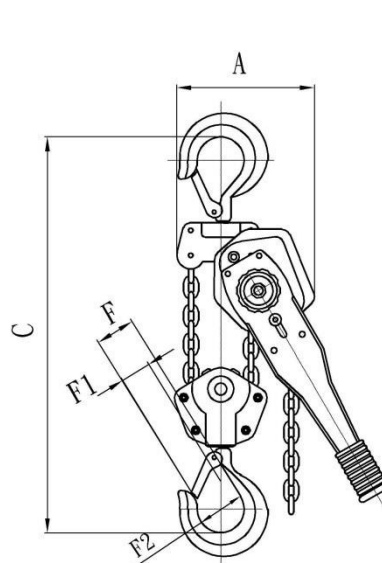
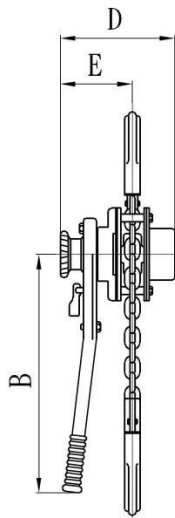

6.0t

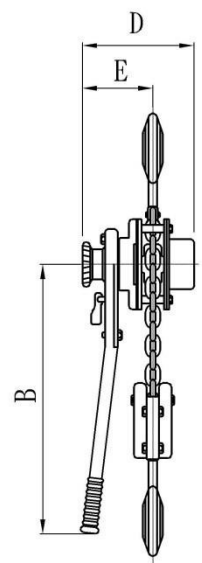

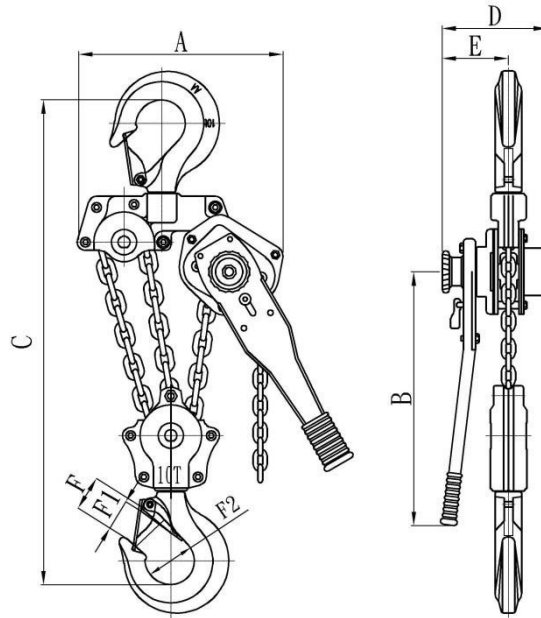

**10.0t**

### Hook Technical Data

Capacity (Tonnes)	Collar measurements (mm)		Hook thickness at point shown in diagram (mm)		Hook throat Opening (mm)	"EZ Check" measurement (mm)
	a	b	c	d		
0.8	8	13.5	23	17	33	52
1.5	10	15.5	26	21	38	59
3.0	12.5	20	37	32	40	76
6.0	19	30	43	36	54	86
10.0	20	33	52	48	60	121

## Tiger Lifting *Home of the Tiger hoisting range & Tiger subsea lifting products*

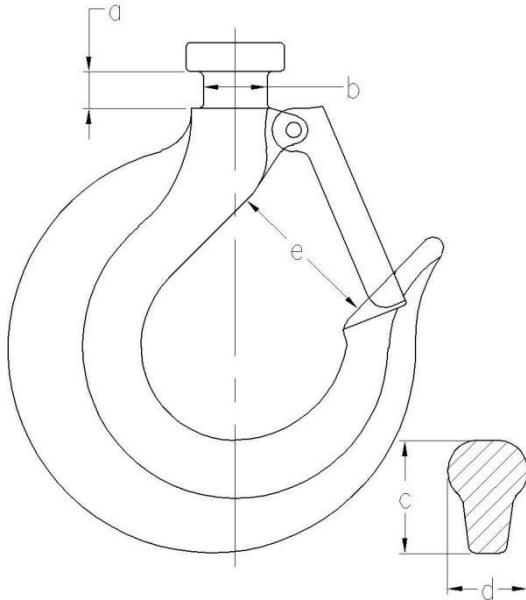

Traditional Tiger Hooks

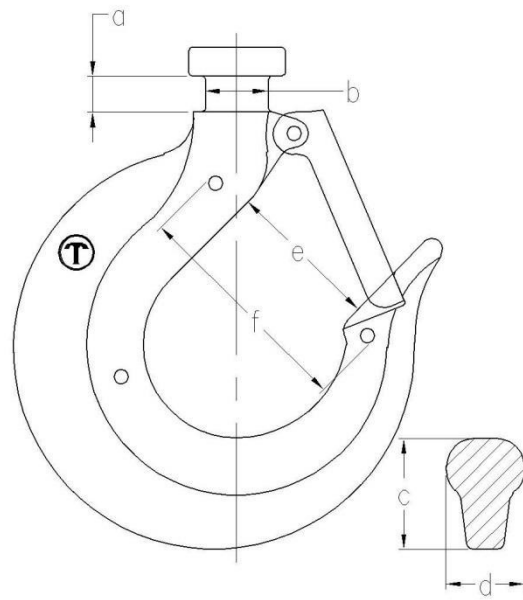

Tiger Hooks with new "EZ Check"  
3 point marking system

Newer models are fitted with the patent pending Tiger "EZ check" 3 point marking system. With this system a quick check that the A and B measurements are the same (as shown in the diagram below) will indicate if the hooks have stretched. If  $A \approx B$  the hook is fine; if  $A > B$  the hook needs to be replaced:

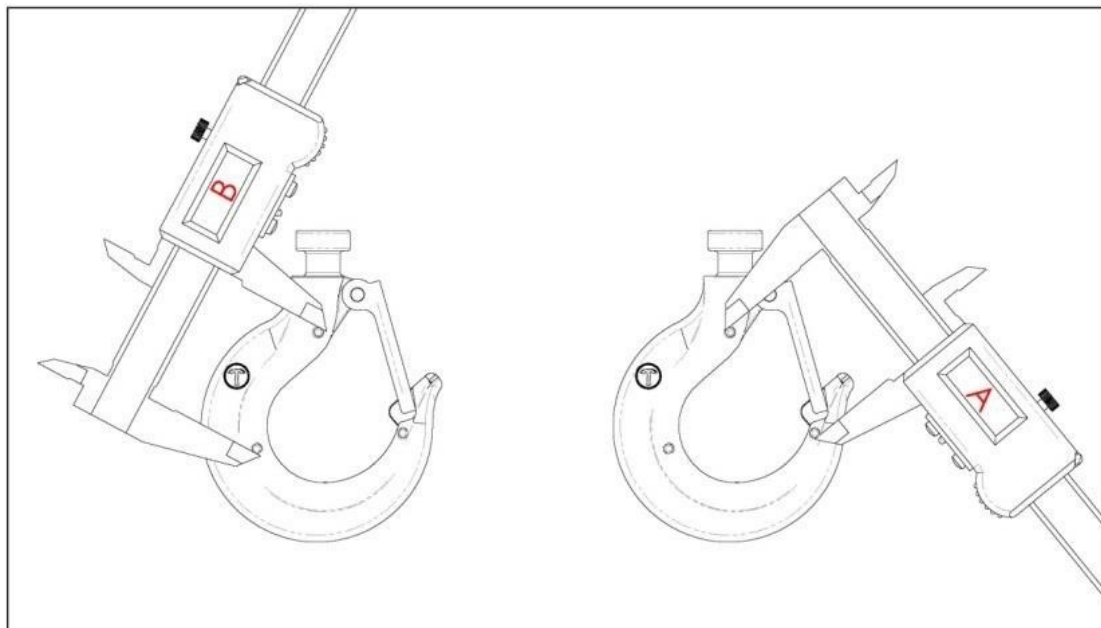



## Tiger Lifting *Home of the Tiger hoisting range & Tiger subsea lifting products*

Due to our policy of continual product development, dimensions, weights and specifications may change without prior notice. Please check with your Tiger sales team when ordering.

Available from

### **DALE**

Lifting and Handling Specialists  
2 Kelbrook Road  
Manchester  
M11 2QA

Telephone 0161 223 1990

Facsimile 0161 223 6767

Email [sales@dale-lifting.co.uk](mailto:sales@dale-lifting.co.uk)

Website [www.dhonline.co.uk](http://www.dhonline.co.uk)

